

2023



MADHYA PRADESH BHOJ (OPEN)
UNIVERSITY, BHOPAL (M.P.)

Post Graduate Diploma in Energy Management



MADHYA PRADESH BHOJ OPEN UNIVERSITY: BHOPAL

SELF-LEARNING MATERIAL

WIND AND HYDRO ENERGY

PGDRE 104

COURSE INTRODUCTION

PART -1

COURSE 1: ENERGY AND ENVIRONMENT

- UNIT-1 : ECOLOGICAL PRINCIPLES AND ENERGY FLOW
- UNIT-2 : ENERGY SCENARIO AND DEVELOPMENT
- UNIT-3 : MAJOR ENERGY RESOURCES OF THE WORLD
- UNIT-4 : ENVIRONMENT CONCERNS OF ENERGY EXTRACTION
- UNIT-5 : ENERGY USE & CLIMATE CHANGE
- UNIT-6 : SUSTAINABILITY ISSUES OF ENERGY USE
- UNIT-7 : SOCIO- ECONOMICAL ASPECTS OF ENERGY RESOURCES
- UNIT-8 : INTERNATIONAL TREATIES & CONVENTION ON ENVIRONMENTAL MITIGATION

COURSE 2: SOLAR ENERGY

- UNIT-1 : SOLAR RADIATION
- UNIT-2 : BASICS OF SOLAR THERMAL CONVERSION
- UNIT-3 : SOLAR THERMAL SYSTEMS AND APPLICATIONS
- UNIT-4 : SOLAR THERMAL ENERGY CONVERSION
- UNIT-5 : BASICS OF SOLAR PHOTOVOLTAICS
- UNIT-6 : SOLAR PHOTOVOLTAIC ENERGY CONVERSION AND UTILIZATION SYSTEMS
- UNIT-7 : POWER ELECTRONICS FOR PHOTOVOLTAIC

COURSE 3: BIOMASS ENERGY

- UNIT -1 : INTRODUCTION
- UNIT-2 : BIOMASS AS FUEL
- UNIT-3 : BIOCHEMICAL CONVERSION OF BIOMASS FOR ENERGY PRODUCTION
- UNIT-4 : LIQUID BIOFUEL CR 3
- UNIT-5 : CHEMICAL CONVERSION OF BIOMASS FOR ENERGY PRODUCTION
- UNIT-6 : SYNTHESIS BIOFUEL
- UNIT-7 : THERMO-CHEMICAL CONVERSION OF BIOMASS
- UNIT-8 : ENERGY PLANTATION

COURSE 4: WIND AND HYDRO ENERGY

- UNIT-1 : WIND RESOURCE ASSESSMENT
- UNIT-2 : AERODYNAMICS OF WIND TURBINE
- UNIT-3 : WIND ENERGY CONVERSION SYSTEMS
- UNIT-4 : WIND ENERGY SYSTEMS: ENVIRONMENT AND ECONOMICS
- UNIT-5 : HYDRO-POWER
- UNIT-6 : BASICS OF FLUID MECHANICS
- UNIT-7 : COMPONENTS OF HYDROPOWER PLANTS
- UNIT-8 : HYDROPOWER PLANT DEVELOPMENT

COURSE 5: NEW ENERGY RESOURCES

- UNIT-1 : BACKGROUND
- UNIT-2 : HYDROGEN ENERGY
- UNIT-3 : FUEL CELL
- UNIT-4 : OCEAN ENERGY
- UNIT-5 : GEOTHERMAL ENERGY
- UNIT-6 : MAGNETOHYDRODYNAMIC00.(MHD)
- UNIT-7 : ELECTROCHEMICAL ENERGY STORAGE SYSTEM
- UNIT-8 : MAGNETIC AND ELECTRIC STORAGE SYSTEM

DRE 104: WIND AND HYDRO ENERGY

UNIT-1: WIND RESOURCE ASSESSMENT

UNIT STRUCTURE

1.0 INTRODUCTION

1.1 HISTORY OF WIND ENERGY

1.1.1 CURRENT STATUS AND FUTURE PROSPECTS

1.1.2 WIND ENERGY IN INDIA

1.2 POWER AVAILABLE IN WIND

1.2.1 TYPES OF WIND TURBINES : HORIZONTAL AND VERTICAL AXIS

1.2.1.1 HORIZONTAL AXIS WIND TURBINE (HAWT)

1.2.1.2 VERTICAL AXIS WIND TURBINE (VAWT)

1.2.2 WIND TURBINE POWER AND TORQUE CHARACTERISTICS

1.2.3 CHARACTERISTICS OF WIND ROTORS

1.3 WIND REGIME ANALYSIS

1.3.1 SITE SELECTION: WIND SHEAR, TURBULENCE AND ACCELERATION EFFECTS

1.3.1.1 WIND SHEAR

1.3.1.2 TURBULENCE

1.3.1.3 ACCELERATION EFFECTS

1.3.2 MEASUREMENT OF WIND: ECOLOGICAL INDICATOR, ANEMOMETERS AND WIND DIRECTIONS

1.3.2.1 ECOLOGICAL PARAMETERS

1.3.2.2 ANEMOMETERS AND WIND DIRECTIONS

1.3.3 WIND VELOCITY

1.3.3.1 TIME DISTRIBUTION

1.3.3.2 FREQUENCY DISTRIBUTION

1.3.3.3 MEAN WIND SPEED

1.3.3.4 DISTRIBUTION OF WIND VELOCITY

1.3.4 STATISTICAL MODEL FOR WIND DATA ANALYSIS, WEIBULL DISTRIBUTION

1.3.4.1 WEIBULL DISTRIBUTION

1.3.5 ENERGY ESTIMATION OF WIND REGIMES, CAPACITY FACTOR

1.3.5.1 CAPACITY FACTOR

LONG TYPE QUESTIONS

PROBABLE QUESTIONS

Objectives

Wind energy is one of the most cost-effective renewable energy resources. India is in fifth position in world as per installed capacity in wind energy. The power available from wind mainly depends on the wind speed of a particular site. So wind resource assessment is prerequisite before any kind of system installation. The objective of this unit is to introduce the learners about the importance of wind resource assessment, measurement techniques and energy estimation of wind regimes.

INTRODUCTION

Wind turbine technology offers cost-effective solutions to eliminate the dependence on carbon based fuel now used to generate electricity. Additionally, this technology provides electrical energy without any green house gas emissions to the environment. Furthermore, the electricity generation cost from wind energy is lower compared to other conventional electrical energy generation schemes like coal fired steam turbo-alternators or nuclear power plants. Wind turbine technology offers the most cost-effective renewable energy source among all renewable energy sources. In simple way, we can think that a wind turbine is the reverse of an electrical fan. A wind turbine uses wind energy to generate the electricity; a fan uses electricity to generate wind. In more sophisticated terms, a wind turbine converts the kinetic energy of the wind into electrical energy.

This unit describes the history of wind energy development, potential and future prospects. It also describes the power available from wind, types of turbines to convert the energy in wind to useful forms of energy (mechanical or electrical). This unit also explains in details about wind regime analysis, statistical analysis of wind data and energy estimation from wind regimes.

1.1 HISTORY OF WIND ENERGY

Human efforts to harness wind for useful work date back to the ancient times to propel ships and boats. Wind energy used to propel boats along the Nile River as early as 5000 B.C. Later, wind energy served the mankind for grain grinding and water pumping. During its transformation from these crude and heavy devices to today's efficient and sophisticated machines, the technology has gone through various phases of development.

There is no proper conclusive information on the origin of the concept of using wind for mechanical power. Some believe that the concept originated in ancient Babylonia. Others argue that the birth place of wind mills is India or in China. The earliest documented design of wind mill dates back to 200 B.C. The first windmills were developed to automate the tasks of grain-grinding and water-pumping and the earliest-known design is the vertical axis system developed in Persia about 500-900 A.D. Vertical-axis windmills were also used in China, which is often claimed as their birthplace. While the belief that the windmill was invented in China more than 2000 years ago is widespread and may be accurate. The earliest actual documentation of a Chinese windmill was in 1219 A.D. by the Chinese statesman Yehlu Chhu-Tshai. Here also, the primary applications were apparently for grain grinding and water pumping.

The first windmills to appear in Western Europe were of the horizontal-axis configuration. By the 13th century, grain grinding mills were popular in most of Europe. As early as 1390, the Dutch set out to refine the tower mill design, which had appeared somewhat earlier along the Mediterranean Sea. French adopted this technology by 1105 A.D. and the English by 1191 A.D. In contrast with the vertical axis Persian design,

European mills were horizontal axis type. These windmills were built with beautiful structures. The tower was circular or polygonal in cross-section and constructed by wood or brick. The Dutch, with renowned designer Jan Adriaenszoon, were the pioneers in making these mills. They made many improvements in the design and invented several types of mills. The rotors were made with crude airfoil profile to improve the efficiency. These wind mills reached America by mid-1700, through the Dutch settlers.

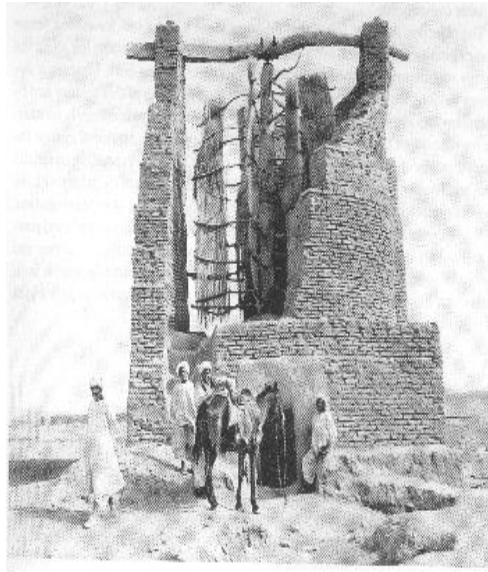

Figure 1: Early windmill for water pumping (900AD)

This is followed by the water pumping wind mill, which is still considered as one of the most successful application of wind power. The so-called American multi bladed wind turbine appeared in the wind energy history by the mid-1800. Relatively smaller rotors, ranging from one to several meters in diameter, were used for this application. During the winter of 1887-88 Charles F. Brush built what is today believed to be the first automatically operating wind turbine for electricity generation. It was a giant with a rotor diameter of 17 m (50 ft.) and 144 rotor blades made of cedar wood. The turbine ran for 20 years and charged the batteries in the cellar of his mansion. Despite the size of the turbine, the generator was only a 12 kW model. This is due to the fact that slow rotating wind turbines do not have the particularly high average efficiency. It was Poul la Cour who later discovered that fast rotating wind turbines with fewer rotor blades are more efficient for electricity production than slow moving wind turbines. On 20 December 1890, the journal *Scientific American* had published detailed description of the Brush windmill. It is particularly noted for its fully automated electrical control system. Its principle using solenoids has not change very much with the future generations of wind turbines - until about 1980 when the wind turbine controllers become equipped with computers.

Poul la Cour (1846-1908) who was originally trained as a meteorologist was the pioneer of modern electricity generating wind turbines. La Cour was one of the pioneers of modern aerodynamics, and built his own wind tunnel for experiments. La Cour was concerned with the storage of energy, and used the electricity from his wind turbines for electrolysis to produce hydrogen for the gas light in his school. One basic drawback of this scheme was the fact that he had to replace the windows of several school buildings several times, as the hydrogen exploded due to small amounts of oxygen in the hydrogen. The world's first Journal of *Wind Electricity* was also published by Poul la Cour. In 1918, some 120 local utilities in Denmark had wind turbine, typically of a size from 20 to 35 kW for a total of some 3 megawatt installed power. These

turbines covered about 3 per cent of Danish electricity consumption at the time. The Danish interest in wind power diminishes in subsequent years, however, until a supply crisis set in during World War II.



Figure 2: An ancient windmill in the British Isles
(Source: Wikipedia, <http://www.wikipedia.org>)

The era of modern wind electric generators began close to 1900's. The first modern wind turbine, specifically designed for electricity generation, was constructed in Denmark in 1890. It supplied electricity to the rural areas. More systematic methods were adopted for the engineering design of turbines during this period. With low-solidity rotors and aerodynamically designed blades, these systems provide impressive field performance. By 1910, several hundreds of such machines were supplying electrical power to the villages in Denmark. By about 1925, wind electric generators became commercially available in the American market. Similarly, two and three bladed propeller turbines ranging from 0.2 to 3 kW in capacity were available for charging batteries. The first utility-scale system was installed in Russia in 1931. A 100 kW turbine was installed on the Caspian Sea shore. Experimental wind plants were subsequently constructed in other countries like United States, Denmark, France, Germany and Great Britain. Some milestones in the history of wind machines are given in Table 1



Figure 3: An ancient Spanish ‘wind farm’
 (Source: Wikipedia, <http://www.wikipedia.org>)

Table 1: Historical development of Wind Energy Conversion System

Period	Machine	Application
640 AD	Persian wind mills	Grinding, etc
Before 1200 AD	Chinese sail type wind mill	Grinding, water pumping, etc
12th century AD	Dutch wind mills	Grinding, water pumping, etc
1700 AD	Dutch w/mill to America	
1850 to 1930 AD	American Multi-bladed	Water pumping, 35 V DC power
1888 AD	Brush wind turbine; Dia.17m, Tower 18.3m	12 kW Electric power
1925 AD	Jacob’s 3 bladed propeller Dia.5m, 10-20m/h, 125 to 225 rpm	0.8 to 2.5 kW at 32 VDC
1931 AD	Yalta Propeller, Russia; 2 bladed, dia.100 ft	100 kW
1941 AD	Smith-Putnam Propeller 2 bladed, dia.175ft, 30 m/h, 28 rpm	1250 kW
1925 AD	Savonius Machine	Mechanical or Electrical power
1931 AD	Darrieus	Electrical power
1980s AD	2 bladed propeller (Commercially available)	225 kW
2000 AD	HAWT, VAWT	400-625kW, 1.2-3.2 MW

Darrieus G.J.M, a French engineer, conceived the design of Darrieus turbine in 1920, which was patented in United States in 1931. In contrast with the popular horizontal axis rotors, Darrieus turbines had narrow curved blades rotating about its vertical axis. Another significant development at this time was the Savonius rotor in Finland, invented by S.J. Savonius. This rotor was made with two halves of a cylinder split longitudinally and arranged radially on a vertical shaft.

In the later years, cheaper and more reliable electricity, generated from fossil fuel based plants became available. Fossil fuels were available in plenty at a relatively cheaper rate due to large availability. Thus, the interest in wind energy declined gradually. However, the oil crisis in 1973, forced the scientists, engineers and policy makers to have a second thought on the fossil fuel dependence and revived the interest on renewable energy and in particular to wind energy. Research on resource analysis, hardware development, and cost reduction techniques were intensified. United States entrusted its National Aeronautics and Space Administration (NASA) with the development of large wind turbines. During the same period, scientists at Sandia Laboratories focused their research on the design and development of the Darrieus turbine.



Figure 4: Modern offshore wind farm

1.1.1 CURRENT STATUS AND FUTURE PROSPECTS

Wind is the world's fastest growing energy source today and it has been retaining this position consecutively for the last few years. The global wind power capacity has increased substantially during the last five years. The total global installed capacity is 175,000 MW in June 2010. Installed capacity in different countries is shown in Table 2. With the increasing thrust on renewable and reducing cost of wind generated electricity, the growth of wind energy will continue in the years to come. All together, wind turbines installed globally by the end of the year 2010 contribute potentially 430 Tera-watt-hours to the worldwide electricity supply which represents 2.5 % of the global electricity demand. China became number two in total installed capacity and the center of the international wind industry related activities. China added 18,928 Megawatt within one year, accounting for more than 50 % of the world market for new wind turbines. Asia accounted for the largest share of new installations (54.6 %), followed by Europe (27.0 %) and North America (16.7 %).

In some of the countries and regions, wind has become one of the major sources of electricity. Again in terms of wind share in country's electricity supply, Denmark is the world leader. In China, wind contributed 1.2 % to the overall electricity supply, while in the USA the wind share has reached about 2 %. The countries with the highest wind shares are:

Denmark	:	21 %
Portugal	:	18 %
Spain	:	16 %
Germany	:	9 %

In tune with the growth of the industry, the wind energy technology is also changing. One apparent change is the shift towards offshore installations. Total installed offshore wind capacity amounted to 3117.6 MW, out of which 1161.7 MW were added in 2010. This represents a growth rate of 59 %, far above the average growth rate of the wind sector. The share of offshore in total wind capacity worldwide went up from 1.2 % in 2009 to 1.6 % in 2010. The share of offshore capacity in new installations went up to 3.1 %. Another trend in the industry is to move for larger machines. As bigger turbines are cheaper on a unit kW basis, the industry is

growing from MW to multi-MW scale. The 2 MW+ sector is rapidly growing. Several manufactures are coming up with turbines of even 5 MW size. The most dynamic progress of the wind industry took place in Asia, and the focus of the global wind sector moved further away from Europe and North America. Asia became the new continental leader, accounting for 54.6 % of the newly installed wind turbines (40.4 % in 2009, 31.5 % in 2008). Asia became the focal point of the wind industry worldwide in 2010, mainly due to the high growth rate in China but also due to the robust development in India. The total installed wind capacity in Asia reached 61.2 GW (31.1 % of the global capacity).

Table 2: Global leaders in wind energy generation

Position	Country	Total installed capacity (MW), June 2010
1	USA	36,300
2	China	33,800
3	Germany	26,400
4	Spain	19,500
5	India	12,100
6	Italy	5,300
7	France	5,000
8	United Kingdom	4,600
9	Portugal	3,800
10	Denmark	3,700
	Rest of the world	24,500
	Total	175,000

Source: World Wind Energy Association Report 2010

1.1.2 WIND ENERGY IN INDIA

The Wind power programme in India was initiated towards the end of the Sixth Plan, in 1983-84. A market-oriented strategy was adopted from inception, which has led to the successful commercial development of the technology. The broad based National programme includes wind resource assessment activities, research and development support, implementation of demonstration projects to create awareness and opening up of new sites, involvement of utilities and industry, development of infrastructure capability and capacity for manufacture, installation, operation and maintenance of wind electric generators and policy support. The programme aims towards commercialization of wind power generation in the country. The Wind Resources Assessment Programme is being implemented through the State Nodal Agencies, Field Research Unit of Indian Institute of Tropical Meteorology (IITM-FRU) and Center for Wind Energy Technology (C-WET).

Winds in India are influenced by the strong south-west summer monsoon, which starts in May-June, when cool, humid air moves towards the land and the weaker north-east winter monsoon, which starts in October, when cool, dry air moves towards the ocean. During the period March to August, the winds are uniformly strong over the whole Indian Peninsula, except the eastern peninsular coast. Wind speeds during the period November to March are relatively weak, though higher winds are available during a part of the period on the Tamil Nadu coastline.

Table 3: State-wise Wind power potential and installed capacity in India

State	Gross potential (MW)	Total Installed capacity (MW)
Andhra Pradesh	8968	200.2
Gujarat	10,645	2175.6
Karnataka	11,531	1730.1
Kerala	1171	32.8
Madhya Pradesh	1019	275.5
Maharashtra	4584	2310.7
Orissa	255	-
Rajasthan	4858	1524.7
Tamil Nadu	5530	5904.4
Others		4
Total (All India)	48,561	14,158

Wind power potential has been assessed assuming 1% of land availability for wind farms requiring @ 12 ha/MW in sites having wind power density in excess of 200 W/sq.m. at 50 m hub-height (till 31.03.2011)

The development of wind electricity generation in India began in the 1990s, and has significantly increased in the last few years. Although a relative newcomer to the wind industry compared with Denmark or the USA, India has the fifth largest installed wind power capacity in the world. In 2009-10 India's growth rate was highest among the other top four countries. Table 3 represent the wind power potential and installed capacity at different states in India. As of 31 March 2011, the installed capacity of wind power in India was 14158 MW, mainly spread across Tamil Nadu (6000 MW), Maharashtra (2310 MW), Gujarat (2176 MW), Karnataka (1730 MW), Rajasthan (1525 MW), Madhya Pradesh (276. MW), Andhra Pradesh (200 MW), Kerala (33 MW), Orissa (2MW), West Bengal (1.1 MW) and other states (3.20 MW). It is estimated that 6,000 MW of additional wind power capacity will be installed in India by 2012. Wind power accounts for 6% of India's total installed power capacity, and it generates 1.6% of the country's power. Fig 5 represents the wind energy map of India. It shows the color representation depending on wind power density in watts/sq.m. Table 4 shows the growth rate of wind installation in the different states from 2006 to 2011 and Table 5 presents the location of wind power projects which are above 20 MW in the country.

Table 4: Installed Capacity per state year-wise (MW)

State	March 2011	March 2010	March 2009	March 2008	March 2007	March 2006
Tamilnadu	5904.4	4907	4304.5	3873.4	3492.7	2894.6
Karnataka	1730	1473	1327.4	1011.4	821.1	584.5
Maharashtra	2310.8	2078	1938.9	1755.9	1487.7	1001.3
Rajasthan	1524.8	1088	738.4	538.8	469.8	358.1
Andhra Pradesh	200.2	236	122.5	122.5	122.5	121.1
Madhya Pradesh	275.5	229	212.8	187.7	57.3	40.3
Kerala	32.8	28	27.0	10.5	2	2
Gujarat	2175.5	1864	1566.5	1252.9	636.6	338
Others	0	4	1.1	1.1	1.1	1.1
Total	14158	11807	10242.3	8754.0	7090.8	5341

Source: Indian Wind Energy Association Report

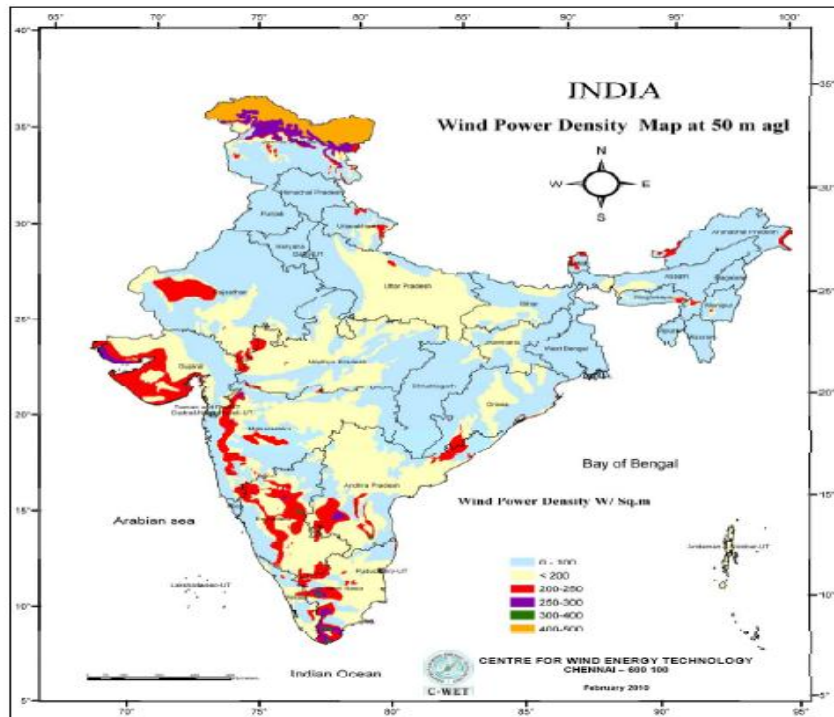

Figure 5: Wind Energy Map of India (Source: CWET)
 Table 5: Wind power projects in India (20MW and greater)

Power Plant	Producer	Location	State	Total capacity (MWe)
Vankusawade Wind Park	Suzlon Energy Ltd.	Satara Dist.	Maharashtra	259
Cape Comorin	Aban Loyd Chiles Offshore Ltd.	Kanyakumari	Tamil Nadu	33
Kayathar Subhash	Subhash Ltd.	Kayathar	Tamil Nadu	30
Ramakalmedu	Subhash Ltd.	Ramakalmedu	Kerala	25
Muppandal Wind	Muppandal Wind Farm	Muppandal	Tamil Nadu	22
Gudimangalam	Gudimangalam Wind Farm	Gudimangalam	Tamil Nadu	21
Puthlur RCI	Wescare (India) Ltd.	Puthlur	Andhra Pradesh	20

Source: Wikipedia, www.wikipedia.org

1.2 POWER AVAILABLE IN WIND

Energy available in wind is basically the kinetic energy of large masses of air moving over the earth's surface. Blades of the wind turbine receive this kinetic energy, which is then transformed to mechanical or electrical forms, depending on the end use. The efficiency of converting wind to other useful energy forms greatly depends on the efficiency with which the rotor interacts with the wind stream. The air mass with density ρ is flowing with a velocity V through an area A represents a mass flow rate of

$$\dot{m} = \rho AV \quad \left(\frac{kg}{s} \right)$$

The kinetic energy of the air stream with mass flow rate \dot{m} and moving with a velocity V is given by (Figure 6)

$$E = \frac{1}{2} \dot{m} V^2$$

or

$$E = \frac{1}{2} \rho A V^3$$

Where ρ is the density of air (kg/m³). The energy per unit time, that is power, can be expressed as

$$P = \frac{1}{2} \rho A V^3 \quad [1]$$

The unit of output power is (kg/m³) × m² × m³/s³ = kg-m²/s³ = J/s = Watts. The distinction between power and energy is important. If a wind turbine operates at a constant power of 10 kW for 2 h, then it will produce 20 kWh of energy, which is 72 million J (or Watt-seconds).

From the above equation, we can notice that the factors influencing the power available in the wind stream are the air density, area of the wind rotor and the wind velocity. In words this relation expresses three things.

- (i) Wind power is proportional to the density of the air. Factors like temperature, atmospheric pressure, elevation and air constituents affect the density of air. This means that high in mountains one gets less power at the same wind speed as density is low at higher elevation.
- (ii) Wind power is proportional to the swept area of the rotor blades. Or is proportional to the square of the diameter of the rotor.
- (iii) Wind power is proportional to the cube of the wind velocity. Hence the wind velocity is more prominent owing to its cubic relationship with the power.

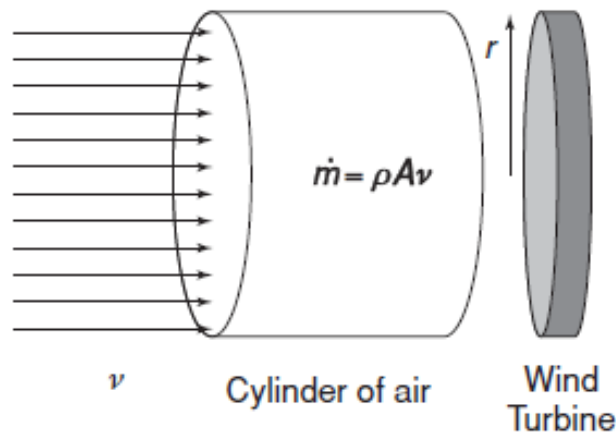

Figure 6: Cylinder of air in front of the rotor

The most important factor deciding the power available in the wind is its velocity. When the wind velocity is doubled, the available power increases by eight times. In other words, it is very important to select the sites with high wind velocity for maximum power output.

The impact of change in radius of the rotor by a small amount Δr , while all else is constant, can be expressed as:

$$\frac{\Delta P}{P} = \frac{2\Delta r}{r}$$

This means that if the radius is increased or decreased by 1%, power will increase or decrease by 2%. For larger changes in radius, the above formula does not apply; for instance, a 10% increase in radius will lead to increase by 21% in power. A 20% increase in radius will lead to 44% increase in power.

If wind speed is changed by a small amount and all else is constant, then

$$\frac{\Delta P}{P} = \frac{3\Delta V}{V}$$

This means that if the speed is increased or decreased by 1%, energy will increase or decrease by 3%. However, if the wind speed is increased by 10%, the power will increase by 33%. From Fig 7, we can observe the variation of power with the increase of wind velocity for a rotor with radius 1m.

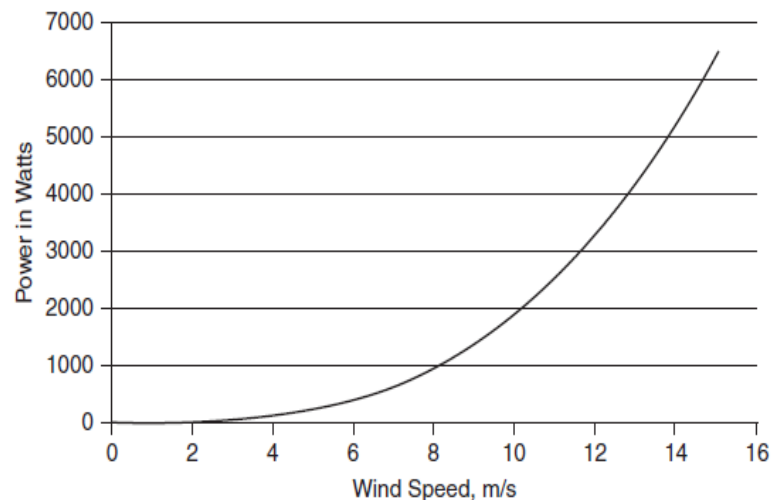

Figure 7: Cubic relationship between power and wind speed for a horizontal axis wind rotor with radius = 1 m.

Example 1

Find the radius of the rotor of a wind turbine which gives an output of 250 watt at a site with wind velocity 5 m/s.

We know the power available from wind is $P = \frac{1}{2} \rho A V^3$; Where, ρ is the air density (kg/m^3), A is the rotor swept area (m^2) and V is the wind velocity (m/s). The density of air is 1.12 kg/m^3 .

$$\text{So the radius of the rotor will be } R = \sqrt{\frac{2 \times P}{\pi \times \rho \times V^3}} = \sqrt{\frac{2 \times 250}{3.14 \times 1.12 \times 5^3}} = 1.1 \text{ m}$$

1.2.1 TYPES OF WIND TURBINES : HORIZONTAL AND VERTICAL AXIS

Several types of wind turbines operate in various regions of the world. Fig 8 presents types of wind turbines. Wind turbines are classified into two major categories: horizontal axis wind turbines (HAWT) and vertical axis wind turbines (VAWT) respectively. The HAWT category includes wind turbines with upwind rotors, wind turbines with downwind rotors, windmill turbines, wind wheel turbines, and turbines with high tip

speed ratios ranging from 1 to 8. The three distinct types of VAWTs are those with Savonius rotor configurations, Darrieus wind turbines and Giromill wind turbines.

1.2.1.1 HORIZONTAL AXIS WIND TURBINE (HAWT)

If the rotor blades are connected with a horizontal shaft, the device is an HAWT. Such turbines are widely used for commercial applications. The gear box and generator are connected to the horizontal shaft and the transformer is located at the base of the tower. A horizontal axis wind turbine may be of upwind design to face the wind or downwind design to enable the wind to pass the tower and nacelle before it hits the rotor. Most modern wind turbines have upwind design configurations and range from prototypes in the MW class to smaller turbines with nominal power output capacities of 20 to 150 kW. The tower height for HAWTs is extremely important because wind speed increases with the height above the ground. Rotor diameter (D) is equally important because it determines the area (A) needed to meet specific output power level. HAWT systems typically deploy two or three rotor blades. HAWT systems are best suited for electrical power generation and micro-turbines composed of two to six rotor blades are most attractive for battery charging applications. A turbine with two rotor blades is cheaper, but it rotates faster, thereby producing a visual flickering effect; also the aerodynamic efficiency of a two-blade rotor is lower than that of a three-blade rotor.

1.2.1.2 VERTICAL AXIS WIND TURBINE (VAWT)

The axis of rotation of vertical axis wind turbine (VAWT) is vertical to the ground and almost perpendicular to the wind direction. The VAWT can receive wind from any direction. The greatest advantage of a VAWT is that the generator and gear box can be installed at the base of the tower, thereby making these components easy to service and repair. Both the Savonius and Darrieus turbines fall into this category and are available commercially. However, these turbines have small output capacities and hence are widely used for low-power applications such as battery charging in areas where power grids are not available.

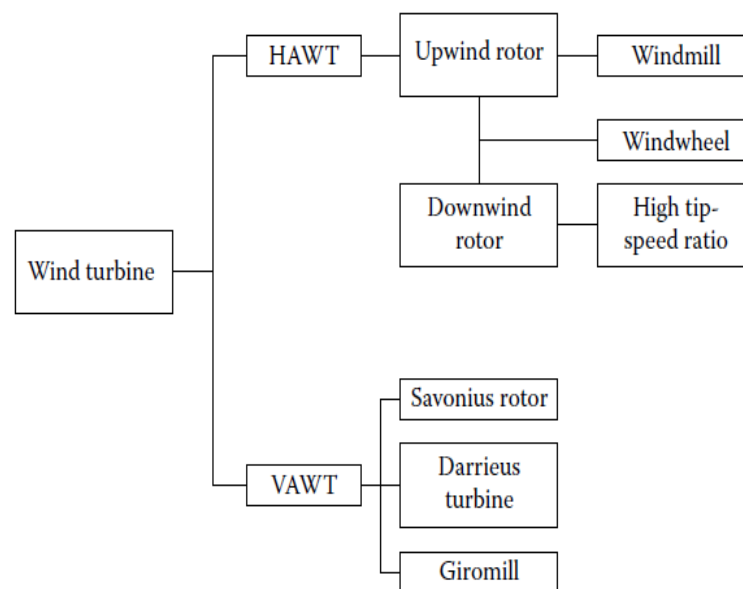

Figure 8: Types of wind turbines

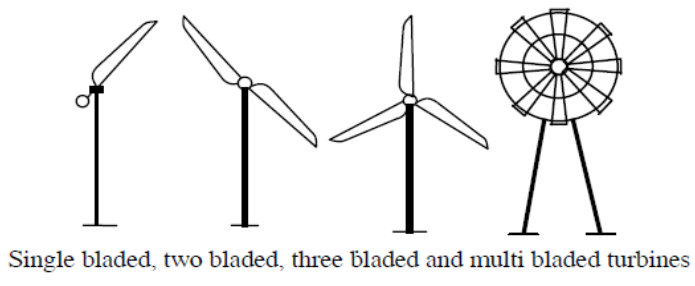
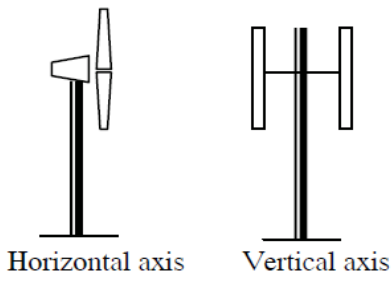

Figure 9: Wind turbine classifications

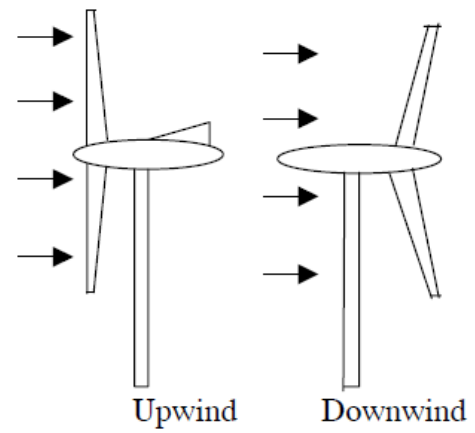

Figure 10: Upwind and downwind HAWT



Figure 11: HAWT for electricity generation

Darrieus rotor

Darrieus rotor, named after its inventor Georges Jean Darrieus, works due to the lift force generated from a set of airfoils (Fig. 12). In the original design the blades are shaped like egg beaters or *troposkein* (turning rope) and are under pure tension while in operation. This typical blade configuration helps in minimizing the bending stress experienced by the blades.

Savonius rotor

The Savonius wind turbine, invented by S.J. Savonius, is a vertical axis machine consisting of two half cylindrical (or elliptical) blades arranged in 'S' shape (Fig. 13). The basic driving force of Savonius rotor is drag. The drag coefficient of a concave surface is more than the convex surface. Hence, the half cylinder with concave side facing the wind will experience more drag force than the other cylinder, thus forcing the rotor to rotate.



Figure 12: VAWT (Darrieus type) for electricity generation



Figure 13: VAWT (Savonius type) for electricity generation

1.2.2 WIND TURBINE POWER AND TORQUE CHARACTERISTICS

A wind rotor can extract power from the wind because it slows down the wind- not too much, not too little. Theoretical power available in a wind stream is given by Eq. (1). However, a turbine cannot extract this power completely from the wind. When the wind stream passes the turbine, a part of its kinetic energy is transferred to the rotor and the air leaving the turbine carries the rest away. Actual power produced by a rotor would thus be decided by the efficiency with which this energy transfer from wind to the rotor takes place. This efficiency is usually termed as the power coefficient (C_p). Thus, the power coefficient of the rotor can be defined as the ratio of actual power developed by the rotor to the theoretical power available in the wind. At standstill, the rotor obviously produces no power and at very high rotational speeds the air is more or less blocked by the rotor, and again no power is produced. In between these two extreme conditions, there is an optimal rotational speed where the power extraction is at a maximum.

It is also often interesting to know the torque-speed curve of a wind rotor, for example when coupling a rotor to a piston pump with a constant torque. The power P (W), the torque Q (Nm) and the rotational speed Ω (rad/s) are related by a simple law;

$$P=Q \times \Omega$$

With this relation Fig 15 is obtained from Fig 14. It may be concluded that because $Q=P/\Omega$, the torque is equal to the tangent of a line through the origin and some point on the P - Ω curve. As the wind speed increases, power and torques also increases, so for each wind speed, a separate curve has drawn (Fig 14 and 15), both for power and torque.

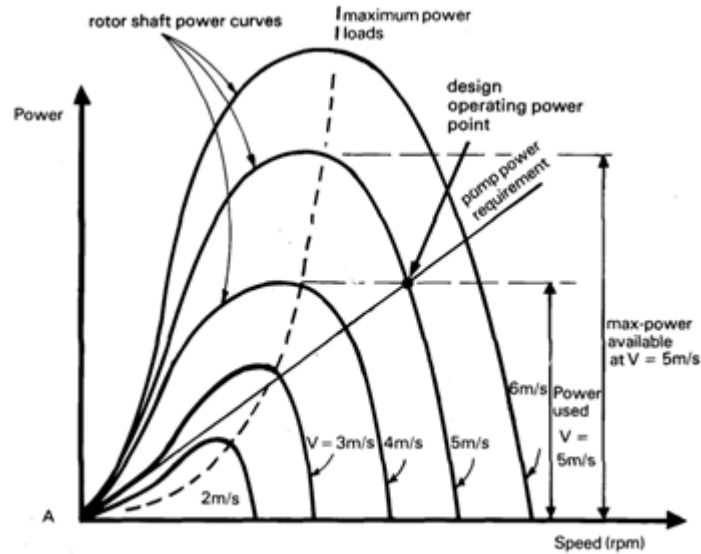

Figure 14: Power produced by a wind rotor as a function of its rotational speed

These groups of curves are rather inconvenient to handle as they vary with the wind speed V , the radius of the rotor R and even the density of the air. Power, torque and speed are made dimensionless with the following expressions.

The power coefficient (C_P) of the rotor can be defined as the ratio of actual power developed by the rotor to the theoretical power available in the wind. Hence, the power coefficient is given by

$$C_P = \frac{P}{\frac{1}{2} \rho A V^3}$$

Power coefficient

The ratio between the actual torque developed by the rotor and the theoretical torque is termed as the torque coefficient (C_Q). Thus, the torque coefficient is given by

$$C_Q = \frac{Q}{\frac{1}{2} \rho A V^2 R}$$

Torque coefficient

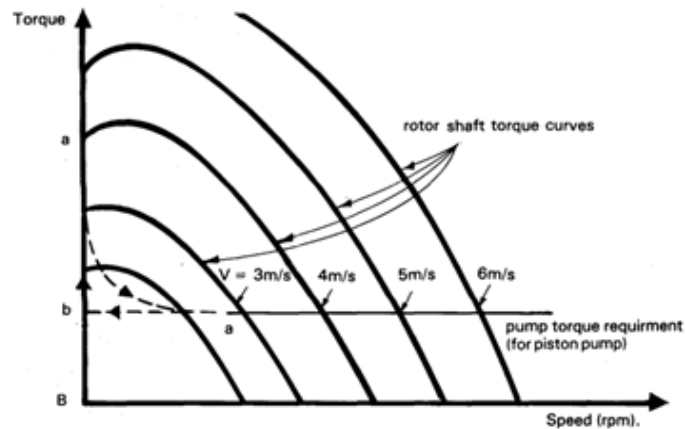

Figure 15: Torque produced by a wind rotor as a function of its rotational speed

The ratio between the velocity of the rotor tip and the wind velocity is termed as the tip speed ratio (λ). Thus, the tip speed ratio can be expressed as;

$$\text{Tip speed ratio } \lambda = \frac{R\Omega}{V} = 2c(NR/V)$$

Where Ω is the angular velocity and N is the rotational speed of the rotor. The power coefficient and torque coefficient of a rotor vary with the tip speed ratio. There is an optimum λ for a given rotor at which the energy transfer is most efficient and thus the power coefficient is the maximum (CP max). Now, let us consider the relationship between the power coefficient, torque coefficient and the tip speed ratio, we can obtain,

$$C_P = C_Q \times \lambda$$

The immediate advantage is that the behaviors of the rotors with different dimensions and at different wind speeds can be reduced to two curves; CP- λ and CQ- λ .

Example 2

Consider a wind turbine with 5 m diameter rotor. Speed of the rotor at 8 m/s wind velocity is 100 r/min and its power coefficient at this point is 0.32. Calculate the tip speed ratio and torque coefficient of the turbine. What will be the torque available at the rotor shaft? Assume the density of air to be 1.12 kg/m³.

$$\text{Area of the rotor is } A = \frac{\pi}{4} \times 5^2 = 19.63 \text{ m}^2$$

As the speed of the rotor is 100 r/min; the angular velocity is

$$\Omega = 2 \times \pi \times N = \frac{2 \times 3.14 \times 100}{60} = 10.47 \frac{\text{rad}}{\text{s}}$$

$$\text{The tip speed ratio at this velocity } \lambda = \frac{R\Omega}{V} = \frac{2.5 \times 10.47}{8} = 3.27$$

$$\text{Torque coefficient is } C_Q = \frac{C_P}{\lambda} = \frac{0.32}{3.27} = 0.098$$

For this, torque developed can be calculated as

$$Q = C_Q \times \frac{1}{2} \times \rho \times A \times v^2 \times R = 0.098 \times 0.5 \times 1.12 \times 19.63 \times 8^2 \times 2.5 = 172.37 \text{ Nm}$$

1.2.3 CHARACTERISTICS OF WIND ROTORS

The efficiency with which a rotor can extract power from the wind depends on the dynamic matching between the rotor and the wind stream. Hence, the performance of a wind rotor is usually characterized by the variations in its power coefficient with the tip speed ratio. As both these parameters are dimensionless, the CP- λ curve represents the rotor performance irrespective of the rotor size and site parameters.

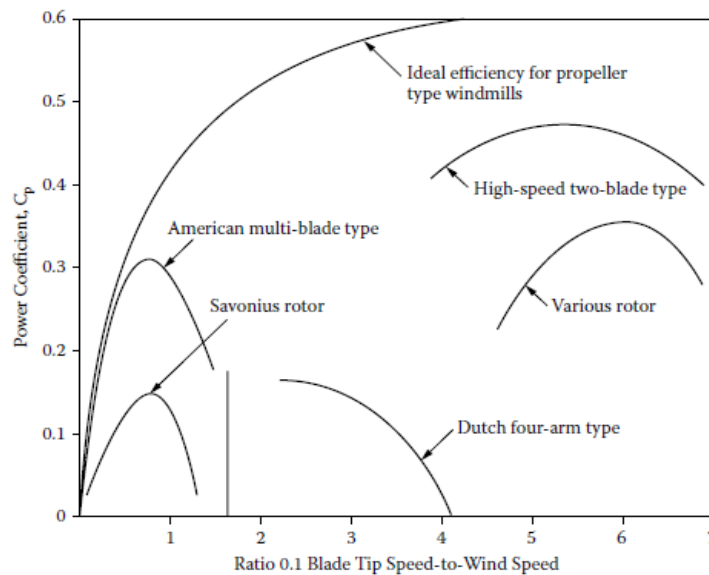

Figure 16: Power coefficient and tip ratio for various wind turbine design

Typical CP- λ curves for different rotors are presented in Fig. 16. In general, initially the power coefficient of the turbine increases with the tip speed ratio, reaches a maximum at a typical value of tip speed ratio, and then decreases with further increase in the tip speed ratio. These variations in CP with λ depend on several design features of the rotor.

American multi-bladed rotors show the low power coefficient and work at low tip speed ratio. A typical value for its peak power coefficient may be 14 per cent at a tip speed ratio of 0.8. However, they have high solidity and hence high starting torque which make them attractive for water pumping. Two and three bladed propeller turbines and the Darrieus type of turbine work at higher tip speed ratios and show better efficiency. Hence, they are suitable for wind-electric generators. Savonius rotors, with its high solidity, work at lower tip speed ratio.

What is the maximum theoretical efficiency that a designer can expect from the wind turbine? Albert Betz, a German physicist, in 1926 had established a limit for the maximum power coefficient for an ideal wind rotor. The axial momentum theory is used to establish that the maximum theoretical power coefficient of a wind turbine, operated predominantly by lift force, is $16/27$ (59.3 per cent). This is known as the Betz limit (we will discuss the axial momentum theory under aerodynamic analysis of wind turbines). On the other hand, the maximum expected power coefficient of a drag machine is $8/27$. This is why lift machines are preferred over drag machines for wind energy conversion.

1.3 WIND REGIME ANALYSIS

Uneven heating of the surface of the earth creates wind. Solar energy absorbed by land or water is transferred to the atmosphere. A larger amount of solar radiation is received at the tropics compared to the poles, which causes hot air to rise at the tropics and flow toward the poles. Air around the poles gets less warm, as the angle at which the radiation reaches the surface is more acute. The density of air decreases with increase in temperature. Thus, lighter air from the equator rises up into the atmosphere to a certain altitude and then spreads around. This causes a pressure drop around this region, which attracts the cooler air from the poles to

the equator. This movement of air causes the wind. *Thus, the wind is generated due to the pressure gradient resulting from the uneven heating of earth's surface by the sun.*

Wind is the result of horizontal differences in air pressure. Air flows from areas of higher pressure to areas of lower pressure. Differences in air pressure are caused by uneven heating of the Earth's surface. Therefore, we can say that the sun (solar energy) is the ultimate cause of wind. Hence, wind energy is a secondary energy source or indirect applications of solar energy.

During the day, the land gets hotter faster, and the hot air rises, creating an area of lower pressure. Wind blows from the sea to the land. This is called sea breeze. At night, the land cools off faster than the sea. Cooler air descends creating an area of higher pressure. Wind blows from the land to the sea. This is called land breeze.

The cause of wind described above, which is driven by the temperature difference, is called the geostrophic wind. The rotation of earth leads to another phenomenon near its surface called the Coriolis Effect, named after the famous mathematician Gustave Gaspard Coriolis. Because of the earth's rotation, any freely moving object or fluid will appear to turn to the right of its direction of motion in the Northern Hemisphere and turn to the left of its direction of motion in the Southern Hemisphere (*for example, note the curved wind arrows in the Figure 17 below*). This causes winds to travel clockwise around high pressure systems in the Northern Hemisphere, and counter-clockwise in the Southern Hemisphere. Due to the Coriolis Effect, the straight movement of air mass from the high pressure region to the low pressure region is diverted as shown in Fig. 17. Under the influence of Coriolis forces, the air move almost parallel to the isobars. Thus, in the northern hemisphere, wind tends to rotate clockwise where as in the southern hemisphere the motion is in the anti-clockwise direction. The arrows between the latitude lines indicate the direction of surface winds. The closed circulation or convection shown on the right indicates the vertical flow of air.

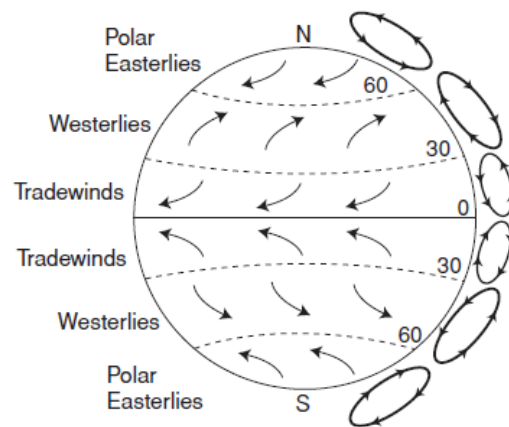

Figure 17: Atmospheric circulation of air

1.3.1 SITE SELECTION : WIND SHEAR, TURBULENCE AND ACCELERATION EFFECTS

The power output of a wind rotor increases with the cube of the wind speed. This means that the site for wind energy conversion systems must be chosen very carefully to ensure that the location has the highest wind speed. The site selection is rather easy in flat terrain but much complicated in hilly or mountain areas. A number of effects need to be considered during site selection.

Wind shear	:	the wind slows down, near the ground, to an extent determined by the surface roughness
Turbulence	:	behind buildings, trees, ridges etc.
Acceleration	:	on the top of the hills, ridges etc.

1.3.1.1 WIND SHEAR

Wind shear describes the change in wind speed as a function of height. Assuming there is no slippage on the surface, the surface wind speed is zero. That is, wind speed is zero at an elevation of zero. Vegetation, buildings and the ground itself cause the wind to slow down near the ground etc. or vice versa. There are two methods to describe wind shear; Power law profile and logarithm profile.

The power law is the most common method to describe the relationship of wind speed and height.

$$\frac{v_2}{v_1} = \left(\frac{h_2}{h_1} \right)^\gamma$$

Where v_2 and v_1 are wind speeds at heights h_2 and h_1 , and exponent γ is called wind shear.

An alternate method to extrapolate wind speed is to use the logarithmic profile, which uses roughness of the surface.

$$\frac{v_2}{v_1} = \frac{\ln(h_2/z_0)}{\ln(h_1/z_0)}$$

Where Z_0 is called the roughness length. If wind speed v_1 is available at $h_1 = 10$ m, then the above equation can be used to compute v_2 . The roughness length or heights for some places are as follows.

Flat	:	beach, ice, snow landscape, ocean	$Z_0 = 0.005$ m
Open	:	low grass, airports, empty crop lands,	$Z_0 = 0.03$ m
		high grass, low crops	$Z_0 = 0.10$ m
rough	:	tall row crops, low woods	$Z_0 = 0.25$ m
very rough:		forests etc	$Z_0 = 0.50$ m
closed	:	villages, suburbs	$Z_0 = 1.0$ m

Example 3

The wind velocity measured at 25 m height at a meteorological observatory is 6 m/s. Find out the velocity at 50 m height at a wind turbine site having similar wind profile. The roughness height at both the location is 0.1 m.

Based on the logarithmic profile method, the wind speed at the height 50m is

$$v_2 = v_1 \frac{\ln\left(\frac{h_2}{z_0}\right)}{\ln\left(\frac{h_1}{z_0}\right)} = 6 \times \frac{\ln\left(\frac{50}{0.1}\right)}{\ln\left(\frac{25}{0.1}\right)} = 6.8 \frac{m}{s}$$

1.3.1.2 TURBULENCE

Wind flowing around buildings or over very rough surfaces exhibits rapid changes in speed and or direction, called turbulence. This turbulence decreases the power output of the wind energy conversion systems and can also lead to fatigue of the machine. Fig 18 presents the region of turbulence behind an obstruction.

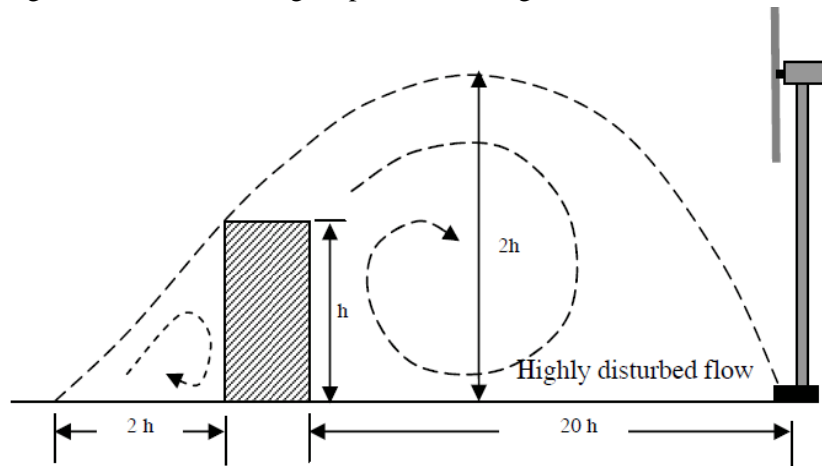

Figure 18: Zone of turbulence over an obstruction

1.3.1.3 ACCELERATION EFFECTS

The tops of ridges experience higher wind speeds due to the effect of wind shear. In the same time, the ridges also acts as a sort of concentrator for the air stream, causing the air to accelerated nearby the top. Generally, it can be said that the effect is stronger when the ridge is rather smooth and not too steep not too flat. The ideal slope angle is said to be 160. Mountain passes are another geographical feature causing acceleration of wind. While the flow passes through the notches in the mountain barriers, due the ventury effect, the wind velocity used to enhance.

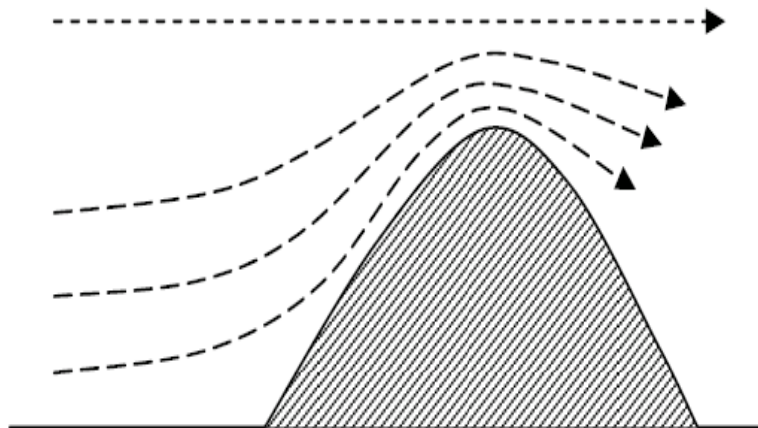

Figure 19: Acceleration of the wind over a ridge

1.3.2 MEASUREMENT OF WIND: ECOLOGICAL INDICATOR, ANEMOMETERS AND WIND DIRECTIONS

Measurement of wind speed is very important as power output from wind energy conversion systems depends on the cube of wind speed. Hence, accurate information about wind speed for a particular site is very much important in determining the best site for wind turbines. Wind speeds are measured in a wide variety of ways, ranging from simple measurements to the most sophisticated electronic systems. The variability of the wind makes accurate measurements difficult, so rather modern equipments are often required. Wind direction is also an important item of information, as well as the correlation between speed and direction. As the wind velocity and thus the power vary from place to place, the first step in planning a wind energy project is to identify a suitable site, having strong and impressive wind data. Speed and direction of wind at a location vary randomly with time. Apart from the daily and seasonal variations, the wind pattern also may change from year to year. Hence, the behavior of the wind at a prospective site should be properly analyzed and understood before starting any wind energy conversion systems installation.

1.3.2.1 ECOLOGICAL PARAMETERS

A quite interesting and easy way to identify a windy site is to observe the biological indicators. Trees and bushes get deformed due to strong winds. The intensity and nature of this deformation depends on the strength of the wind. Strong winds deform trees and shrubs so that they indicate an integrated record of the local wind speeds during their lives. The effect shows up best on coniferous evergreens because their appearance to the wind remains relatively constant during the year. Deciduous trees shed their leaves in the winter and thus change the exposed area tremendously.

Hewson and Wade have proposed a rating scale for tree deformation which is shown in Fig. 20. In this scale 0 corresponds to no wind damage, I, II, III, and IV to various degrees of flagging, V to flagging plus clipping, and VI to throwing. Class VII is a flagged tree with the flagging caused by other factors besides a strong prevailing wind. However, it should be noted that the degree of this deformation may vary from one tree species to the other. For this reason, this method is to be calibrated with long term wind data for a given tree variety. Once such calibration is available, the wind speed range can be directly estimated on the basis of these biological indicators. Once such zones have been identified, it is still important to place wind instrumentation at those sites. The biological indicators help preliminary identification of good sites and eliminate the poor sites without having the precise wind data needed for wind turbine deployment.

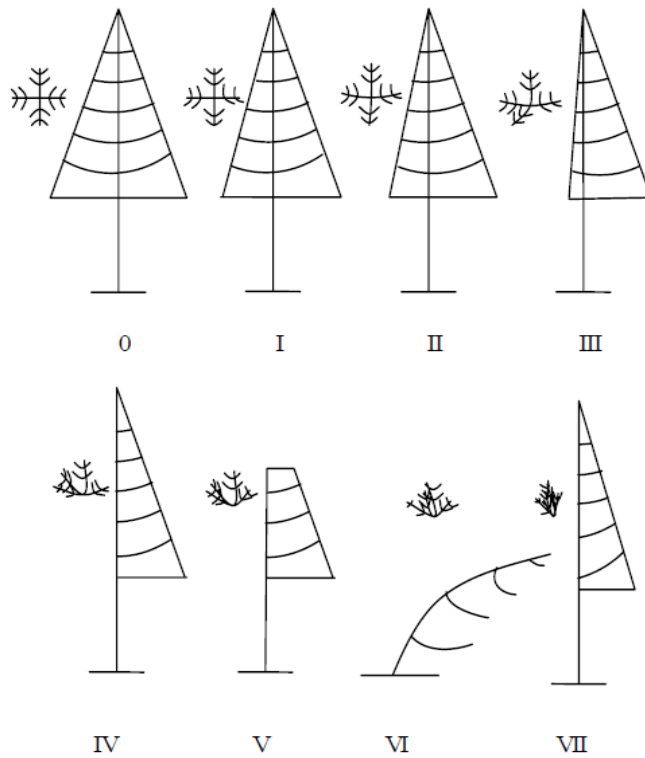

Figure 20: Biological rating scales for the wind speed
 (0: No deformation due to wind, I: Brushing, II: Light flagging, III: Moderate flagging, IV: Strong flagging, V: Flagging and clipping, VI: Throwing and flagging and VII: Extreme flagging)

1.3.2.2 ANEMOMETERS AND WIND DIRECTIONS

Anemometers, instruments that measure the wind speed, have been designed in various ways. Each type has advantages and disadvantages. There are different types of anemometers. Based on the working principle, they can be classified as:

- Rotational anemometers (cup anemometers and propeller anemometers)
- Pressure type anemometers (pressure tube anemometers, pressure plate anemometers and sphere anemometers)
- Thermoelectric anemometers (hot wire anemometers and hot plate anemometers)
- Phase shift anemometers (ultra sonic anemometers and laser doppler anemometers)

The most commonly used anemometer, in wind energy measurements is the cup anemometer. It consists of three (or four) equally spaced cups attached to a centrally rotating vertical axis through spokes (Fig. 21). The cups are hemispherical or conical in shape and made with light weight material. This is basically a drag device. The intensity of rotation is directly proportional to the velocity of incoming wind.

The wind vane used for indicating wind direction is one of the oldest meteorological instruments. Basically, a wind vane (Fig 22) is a body mounted un-symmetrically about a vertical axis, on which it turns freely. The end offering the greatest resistance to the wind goes downwind or to the leeward. Direction of wind is an important factor in the siting of a wind energy conversion system. It is important to know the major share of energy available in the wind from a certain direction to avoid any obstructions to the wind flow from that side.

The best way of measuring wind speeds at a prospective wind turbine site is to fit an anemometer to the top of a mast which has the same height as the expected hub height of the wind turbine to be installed. This way one avoids the uncertainty involved in recalculating the wind speeds to a different height. However, the wind speeds are measured at 10m, 25m and 50m height.



Figure 21: Cup anemometer



Figure 22: Wind vane

1.3.3 WIND SPEED STATISTICS: TIME AND FREQUENCY DISTRIBUTION, MEAN WIND SPEED AND DISTRIBUTION OF WIND VELOCITY

To estimate the wind energy potential of a site, the wind data collected from the location need to be properly analyzed and interpreted. Long term wind data from the meteorological stations near to the potential site or through wind monitoring programme can be used for making these kinds of estimation. Fig 23 represents the wind speed distribution for a certain period of time. It can be observed from the plot that the wind speed is always fluctuating in nature. Hence, it is very much important to analyze this fluctuating wind speed data and try to find out the most probable wind speed or average wind speed based on which the wind energy systems can be designed. To facilitate the judgment to what extent a given location might be suitable for the utilization of wind energy, we will be interested to answer the following questions.

- What is the daily, monthly and annual wind pattern?
- What is the duration of low wind speeds and high wind speeds?
- Which wind speeds can we expect at locations not too far from the place of measurements?
- What is the maximum gust wind speed?
- How much energy can be produced annually?

The hourly wind speed can be the basis of the wind speed analysis and also for the answer of those questions. Here, we will try to analyze the wind data at two aspects

- Time distribution
- Frequency distribution

1.3.3.1 TIME DISTRIBUTION

Plotting the monthly average of each hour of the day represents the diurnal fluctuations of the wind speed in that particular month (Fig 24). In the similar manner, the monthly average can be plotted to represent the monthly fluctuations of the wind speed, compared with the annual average wind speed (Fig 25).

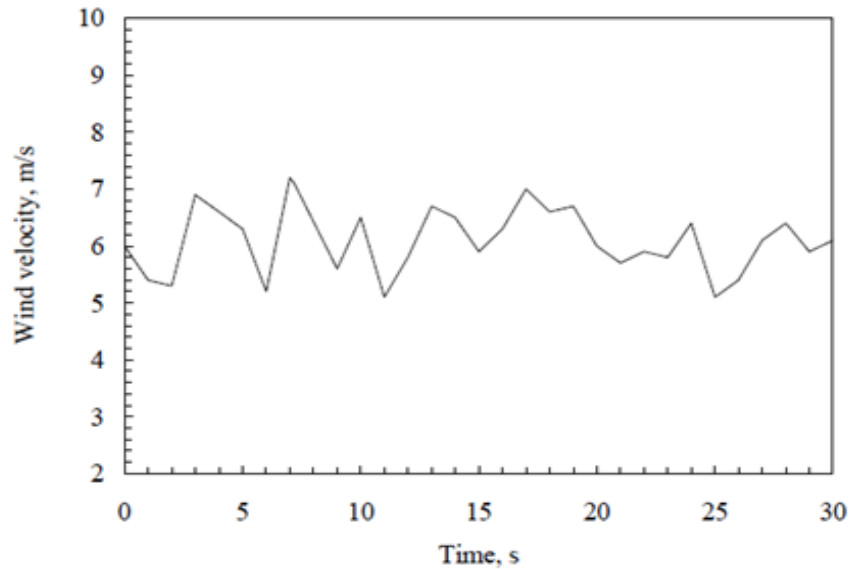

Figure 23: Wind speed distribution with time

1.3.3.2 FREQUENCY DISTRIBUTION

Apart for the distribution of the wind speeds over a day or a year, it is important to know the number of hours per month or per year during which the given wind speed occurs, i.e. the frequency distribution of the wind speeds. To evaluate this frequency distribution, we need to first divide the wind speeds domain into a number of intervals, mostly of equal width of 1 m/s or 0.5 m/s. Then starting at the first interval, of say 0-1m/s, the number of hours is counted in the period concerned that the wind speed was in that interval. When the number of hours in each interval is plotted against the wind speed, the frequency distribution curves looks as a histogram (Fig 26). The top of the histogram, being the most frequent wind speed, is generally not the average wind speed.

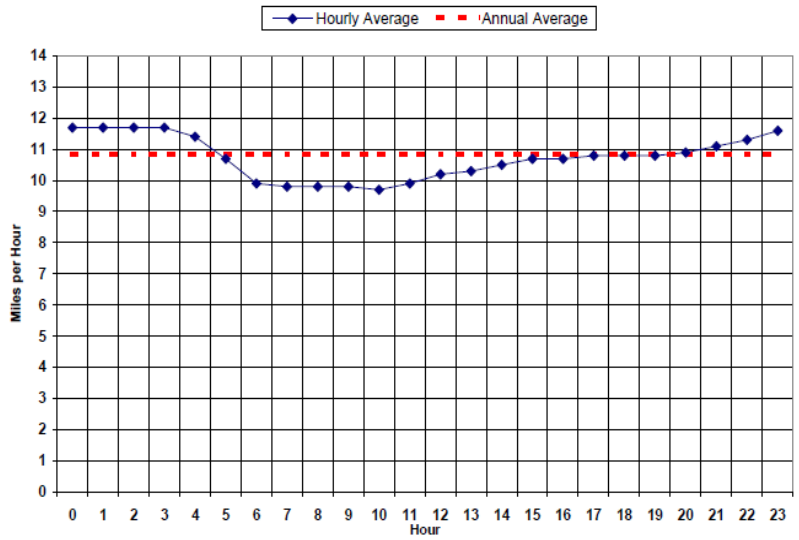

Figure 24: Diurnal wind speed distribution

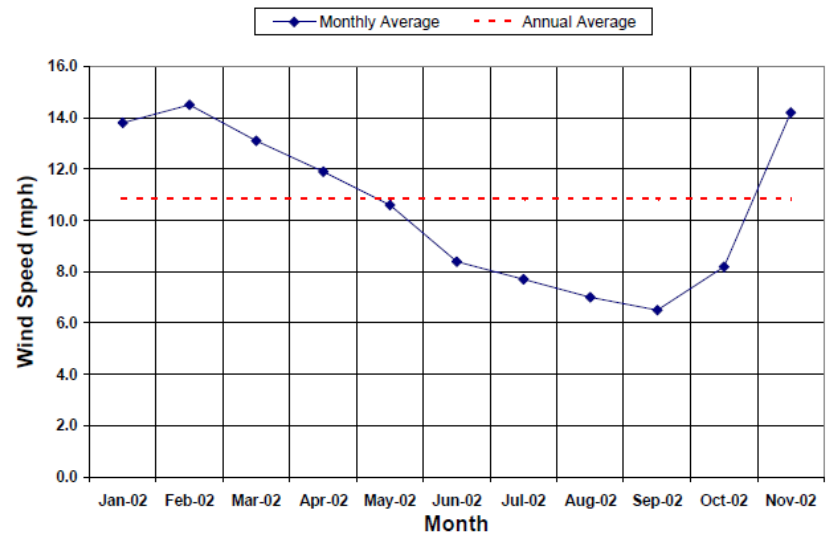

Figure 25: Monthly average wind speed

The frequency duration values (a particular wind speed for how many number of hours in a month or in a year) are plotted with the wind speed on the Y-axis. Now, if the histogram is approximated by a smooth curve through the middle values of each interval then the duration curve comes out (Fig 27). By studying the shape of this duration curve, one can get certain idea about the kind of wind regime. The flatter the duration curve i.e. the longer one specific wind speed persists, the more constant wind regime is. Or, a particular wind speed will occur for relatively longer duration in a month or in a year. The steeper the duration curve, the more irregular the wind regime is. Or, will get a particular wind speed for relatively less time in a month or in a year. These characteristics will be analyzed mathematically in section 1.3.4.

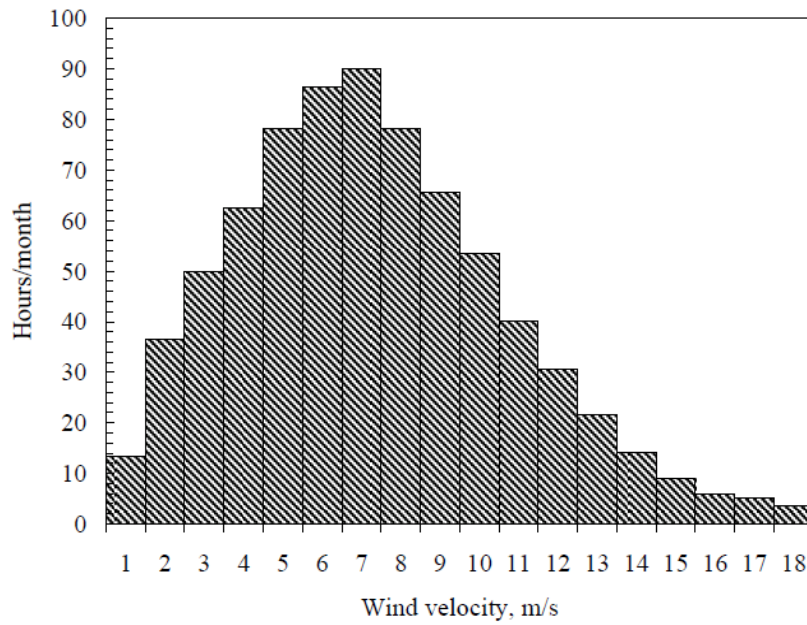

Figure 26: Wind speed frequency distribution

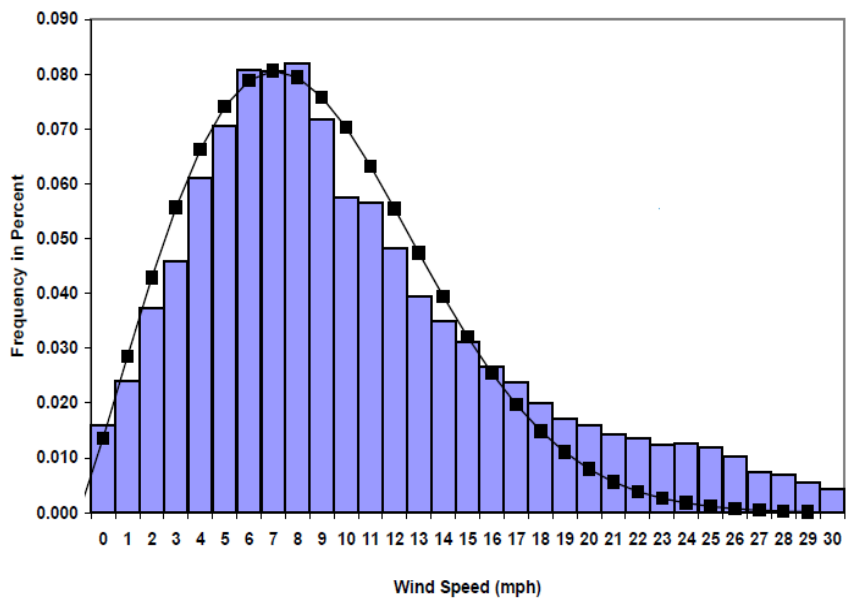

Figure 27: Wind speed frequency distribution

1.3.3.3 MEAN WIND SPEED

The wind speed is continuously changing, making it desirable to describe the wind by statistical methods. We shall pause here to examine a few of the basic concepts of probability and statistics related to wind measured data analysis.

One of the most important information on the wind spectra available at a location is its average or mean velocity. If we have a set of numbers u_i , such as a set of measured wind speeds, the mean of the set is defined as

$$\bar{u} = \frac{1}{n} \sum_{i=1}^n u_i$$

The sample size or the number of measured values is n .

Wind speeds are normally measured in integer values, so that each integer value is observed many times during a year of observations. The numbers of observations of a specific wind speed u_i will be defined as m_i . Then the mean is

$$\bar{u} = \frac{1}{n} \sum_{i=1}^w m_i \times u_i$$

Where w is the number of different values of wind speed observed and n is still the total number of observations.

In addition to the mean, we are interested in the variability of the set of numbers. We want to find out the discrepancy or deviation of each number from the mean and then find some sort of average of these deviations. The mean of the deviations $u_i - \bar{u}$ is zero, which does not tell us much. We therefore square each deviation to get all positive quantities. The *variance* σ^2 of the data is then defined as

$$\sigma^2 = \frac{1}{n-1} \sum_{i=1}^n [(u)_i - \bar{u}]^2$$

The *standard deviation* σ is then defined as the square root of the variance.

$$\text{Standard deviation } (\sigma) = \sqrt{\text{variance}}$$

Example 4

Five measured wind speeds are 4,6,5,8, and 9 m/s. Find out the mean, the variance, and the standard deviation.

The mean wind speed is
$$\bar{u} = \frac{4 + 6 + 5 + 8 + 9}{5} = 6.4 \frac{m}{s}$$

The variance is
$$\sigma^2 = \frac{1}{4[(4 - 6.4)^2 + (6 - 6.4)^2 + (5 - 6.4)^2 + (8 - 6.4)^2 + (9 - 6.4)^2]} = 4.3 \text{ m}^2/\text{s}^2$$

The standard deviation is
$$(\sigma) = \sqrt{4.3} = 2.07 \frac{m}{s}$$

1.3.3.4 DISTRIBUTION OF WIND VELOCITY

We shall now define the *probability* p of the discrete wind speed u_i being observed as

$$p(u_i) = \frac{m_i}{n}$$

With this definition, the sum of all probability will be unity.

$$\sum_{i=1}^w p(u_i) = 1$$

We shall also define the cumulative distribution function $F(ui)$ as the probability that a measured wind speed will be less than or equal to ui .

$$F(u_i) = \sum_{j=1}^i p(u_j)$$

The cumulative distribution function has the properties

$$F(-\infty) = 0 \quad \text{and} \quad F(\infty) = 1$$

1.3.4 STATISTICAL MODEL FOR WIND DATA ANALYSIS, WEIBULL DISTRIBUTION

We used to get smooth curves with a well defined pattern, when we join the midpoints of the wind speed frequency distribution curves (Fig 27). This shows that it is logical to represent the wind velocity distributions by standard statistical functions. Various probability functions were fitted with the field data to identify suitable statistical distributions for representing wind regimes. It is found that the Weibull and Rayleigh distributions can be used to describe the wind variations with an acceptable accuracy level.

It is also convenient for a number of theoretical reasons to model the wind speed frequency curve by a continuous mathematical function rather than a table of discrete values. When we do this, the probability values $p(ui)$ become a density function $f(u)$. The density function $f(u)$ represents the probability that the wind speed is in a 1 m/s interval centered on u . The discrete probabilities $p(ui)$ have the same meaning if they were computed from data collected at 1 m/s intervals. The area under the density function is unity.

The density function now can be written as

$$\int_0^{\infty} f(u)du = 1$$

The cumulative distribution function can be written as

$$F(u) = \int_0^u f(x)dx$$

The variable x inside the integral is just a dummy variable representing wind speed for the purpose of integration. Both of the above integrations start at zero because the wind speed cannot be negative. When the wind speed is considered as a continuous random variable, the cumulative distribution function has the properties $F(0) = 0$ and $F(1) = 1$.

1.3.4.1 WEIBULL DISTRIBUTION

There are several density functions which can be used to describe the wind speed frequency curve. The two most common are the *Weibull* and the *Rayleigh* functions. For the statistically inclined learner, the Weibull is a special case of the Pearson Type III or generalized gamma distribution, while the Rayleigh distribution is a subset of the Weibull ($k=2$). The Weibull is a *two parameter* distribution while the Rayleigh has only *one*

parameter. This makes the Weibull somewhat more versatile and the Rayleigh somewhat simpler to use. Here, we will discuss only the Weibull distribution function. The wind speed u is distributed as the Weibull distribution if its probability density function is

$$f(u) = \frac{k}{c} \left(\frac{u}{c}\right)^{k-1} \exp \left[- \left(\frac{u}{c}\right)^k \right]$$

The probability density function $f(u)$ indicates the fraction of time (or probability) for which the wind is at a given speed u . This is a two parameter distribution where c and k are the *scale parameter* (m/s) and the *shape parameter* (dimensionless) respectively.

The cumulative distribution function of the velocity u gives us the fraction of time (or probability) that the wind velocity is equal or lower than u . Thus the cumulative distribution $F(u)$ is the integral of the probability density function. Thus,

$$F(u) = \int_0^u f(u) du = 1 - \exp \left[- \left(\frac{u}{c}\right)^k \right]$$

The probability density and cumulative distribution functions of a wind regime, following the Weibull distribution are shown in Fig. 28 and 29. It can be seen that the Weibull density function gets relatively narrower and more peaked as k gets larger. The peak also moves in the direction of higher wind speeds as k increases. The peak of the probability density curve indicates the most frequent wind velocity in the regime.

The cumulative distribution function can be used for estimating the time for which wind is within a certain velocity interval. Probability of wind velocity being between u_1 and u_2 is given by the difference of cumulative probabilities corresponding to u_2 and u_1 . Thus

$$P(u_1 < u < u_2) = F(u_2) - F(u_1)$$

That is

$$P(u_1 < u < u_2) = \exp \left[- \left(\frac{u_1}{c}\right)^k \right] - \exp \left[- \left(\frac{u_2}{c}\right)^k \right]$$

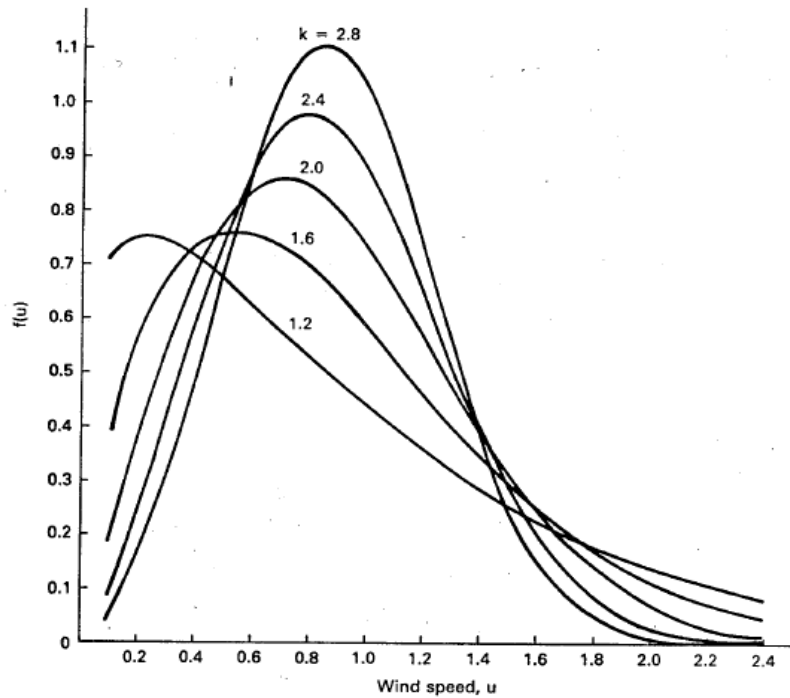

Figure 28: Weibull Probability density function for $c=1\text{m/s}$

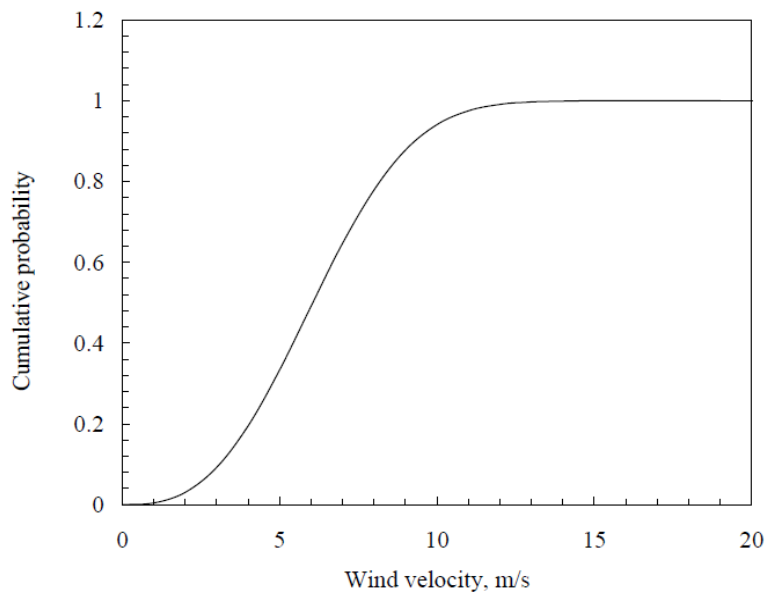

Figure 29: Weibull cumulative distribution function

We are also interested to know the possibilities of extreme wind at a potential location, so that the system can be designed to sustain the maximum probable loads. It also needs to estimate the number of hours per year that the wind speed is greater than or equal to a particular value. Hence, the probability for wind speed is greater than u_x in its velocity is given by

$$P(u > u_x) = \left[1 - \left[1 - \exp \left\{ \left[-\left(\frac{u_x}{c} \right)^k \right] \right\} \right]^k \right] = \exp \left[-\left(\frac{u_x}{c} \right)^k \right]$$

The common methods to estimate the Weibull parameters k and c of the Weibull distribution are;

- Graphical method
- Standard deviation method
- Moment method
- Maximum likelihood method and
- Energy pattern factor method

Example 5

The Weibull parameters at a given site are $c = 6$ m/s and $k = 1.6$. Estimate the number of hours per year that the wind speed will be between 7.5 and 8.5 m/s. Estimate the number of hours per year that the wind speed is greater than or equal to 18 m/s.

The Weibull probability density function of the wind in between 7.5 and 8.5 m/s is just $f(u)$.

So

$$f(8) = \frac{1.6}{6} \left(\frac{8}{6}\right)^{1.6-1} \exp\left[-\left(\frac{8}{6}\right)^{1.6}\right] = 0.065$$

This means that the wind speed will be in this interval for 6.5 % of the time, so the number of hours per year with wind speeds in this interval would be

$$= (0.065) \times (8760) = 570 \text{ h/year}$$

The probability that the wind speed is greater than or equal to 18 m/s is

$$P(u \geq 18) = \exp\left[-\left(\frac{18}{6}\right)^{1.6}\right] = 0.003$$

Which represents, the wind speed is greater than or equal to 18m/s for

$$= (0.003) \times (8760) = 27 \text{ h/year}$$

1.3.5 ENERGY ESTIMATION OF WIND REGIMES, CAPACITY FACTOR

Wind energy density and the energy available in the regime over a period are usually taken as the indicators for evaluating the energy potential of a site. The wind energy density (ED) is the energy available in the regime for a unit rotor area and time. Thus, ED is a function of the velocity and distribution of wind in the regime. We can arrive at the total energy available in the spectra, by multiplying the wind energy density by the time factor. In simple way, the power density is defined as;

$$PD = \frac{\text{Power}}{\text{Area}} = \frac{1}{2} \times \rho \times v^3 \quad \left(\frac{W}{m^2}\right)$$

However, this kind of relation is only valid, if we ignored the statistical distribution of wind speed and assume that there is no variation of wind speed and consider the average wind speed for calculation of power density.

Hence the power density $PD = \frac{1}{2} \times \rho \times \bar{v}^3$; Where \bar{v} is the average or mean wind speed.

However, if the energy density is computed taking into account the probability density of wind speed, then the power density will be

$$PD = \int_0^{\infty} \frac{1}{2} \rho \times v^3 \times f(v) dv$$

Where $f(v)$ is the Weibull distribution function. This relation provides better accurate results in compare to earlier simple relation.

Wind Classes

The strength of wind at a site is classified based on power density at an elevation of 50 m above the ground level. Table 6 presents the various wind classes in terms of power density at 10 and 50 m above the ground.

Table 6: Wind speed ranges and power density at specific heights

Wind class	Wind class name	10 m		50 m	
		Power density (W/m ²)	Average wind speed (m/s)	Power density (W/m ²)	Average wind speed (m/s)
1	Poor	0-100	0-4.4	0-200	0-5.6
2	Marginal	100-150	4.4-5.1	200-300	5.6-6.4
3	Fair	150-200	5.1-5.6	300-400	6.4-7.0
4	Good	200-250	5.6-6.0	400-500	7.0-7.5
5	Excellent	250-300	6.0-6.4	500-600	7.5-8.0
6	Outstanding	300-400	6.4-7.0	600-800	8.0-8.8
7	Superb	400-1000	7.0-9.4	800-2000	8.8-11.9

1.3.5.1 CAPACITY FACTOR

The power curve for a wind turbine indicates the net electrical energy output from a wind turbine as a function of the wind velocity at hub height. A power curve for a grid-connected stall-regulated wind turbine is shown in Fig 30. This curve indicates the following parameters.

Cut-in wind speed: The winds speed at which turbine starts producing power.

Rated wind speed: The wind speed at which the turbine is designed to produce continuous designed rated output

Cut-out wind speed: The wind speed above which the turbine will stop producing any power or turned away from facing the wind to protect the blades, generator or the system structure.

Suppose, we install a wind turbine with power curve as shown in Fig. 30 at a site. It means from this power graph, that the turbine will start generating power at its cut-in wind speed of 5m/s and the generation will be cut-off at 25 m/s. The highest power of 250 kW will be produced at 15 m/s, which is the rated wind speed of the system.

The electrical power output of a wind turbine is a function of the wind speed, the turbine angular velocity, and the efficiencies of each component in the drive train. It is also a function of the type of turbine (propeller, Darrieus, etc.), the inertia of the system, and the gustiness of the wind. However, we can define a model for electrical power output (P_e) that can be used in discussing any wind system. The model what we can use to explain the output in each segment with the following equations for the electrical power output of a model wind turbine:

$$P_e = a + bu^k \quad P_e = 0 \quad u < u_c$$

$$P_e = P_{eR} \quad u_c \leq u \leq u_R$$

$$P_e = P_{eR} \quad u_c < u \leq u_f$$

$$P_e = 0$$

$$u > u_F$$

In the expression, $P_e R$ is the rated electrical power, u_c is the cut-in wind speed, u_R is the rated wind speed, u_F is the cut-out wind speed, and k is the Weibull shape parameter.

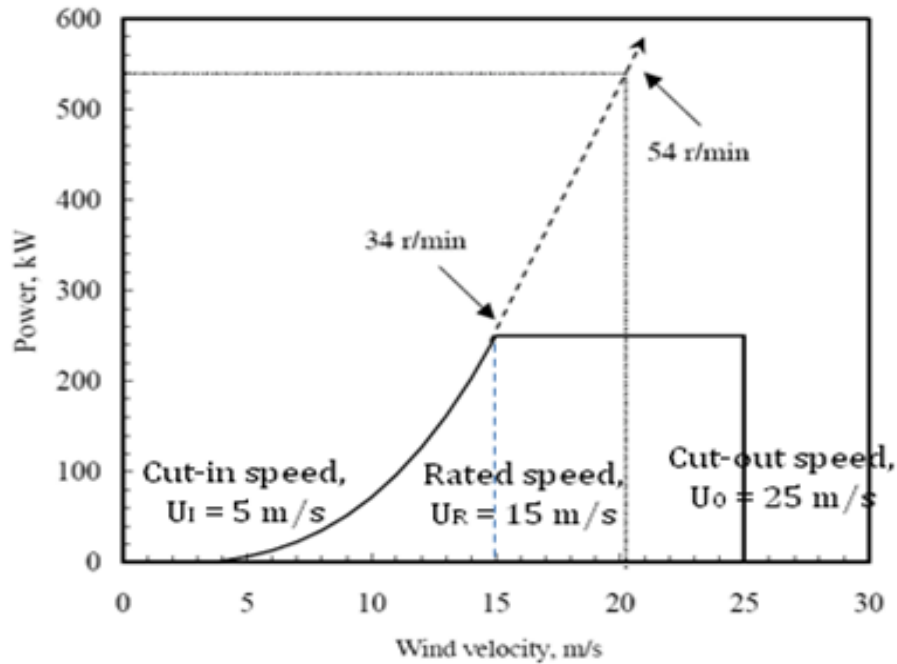

Figure 30: Power curve of a typical wind turbine

It is assumed that the power output can be adequately described by the above model equations. We now want to combine the variation in output power with the variation in wind speed at a site to find the average power $P_{e,ave}$ that would be expected from a given turbine at a given site. The average power output from a turbine is a very important parameter of a wind energy system since it determines the total energy production. The average power output from a wind turbine is the power produced at each wind speed times the fraction of the time that wind speed is experienced, integrated over all possible wind speeds.

So the average power in its integral form can be

$$P_{e,ave} = \int_0^{\infty} P_e f(u) du \quad \square$$

Where $f(u)$ is a probability density function of wind speeds. Here, we shall use the Weibull distribution function

$$f(u) = \frac{k}{c} \left(\frac{u}{c}\right)^{k-1} \exp\left[-\left(\frac{u}{c}\right)^k\right]$$

Now substituting the Weibull distribution function in the above equation, we can have

$$P_{e,ave} = \int_{u_c}^{u_R} (a + bu^k) f(u) du + P_e R \int_{u_R}^{u_F} f(u) du \quad (W) \quad \square$$

There are two distinct integrals which need to be integrated. The final outcome from this integration will be

$$P_{e,ave} = P_e R \left\{ \frac{1 - \exp\left[-\left(\frac{u_R}{c}\right)^k\right]}{k} - \frac{1 - \exp\left[-\left(\frac{u_F}{c}\right)^k\right]}{k} \right\} + \int_{u_c}^{u_R} (a + bu^k) f(u) du \quad \square$$

We now have an equation which shows the effects of cut-in, rated and cut-out wind speeds on the average power production of a turbine. For a given wind regime with known c and k parameters, we can select uc , uR , and uF to maximize the average power, and thereby maximize the total energy production. The quantity inside the brackets of the above equation is called the capacity factor (CF) and sometime also called the plant factor. It is an important design item in addition to the average power.

Now the average power equation can be written as

$$P_{e,ave} = P_{eR} \times CF \quad (W) \square$$

The yearly energy production of such a turbine is

$$P_{e,ave} = P_{eR} \times CF \times 8760 \quad (kWh) \square$$

Where 8760 is the number of hours in a year of 365 days and PeR is expressed in kilowatts.

PROBABLE QUESTIONS

1. Why site selection is so important for wind energy applications?
2. What are the different forms of presenting wind data? Explain the characteristics of a good windy site.
3. How the wind data are represents statistically?
4. What are the main factors for reduction of wind speeds?
5. What is the physical significance of shape and scale parameters of Weibull distribution function?

LONG TYPE QUESTIONS

1. Explain how Weibull distribution function can be evaluated from the hourly data mean wind speed of a month.
2. A wind data acquisition system measures 7 m/s 24 times, 8 m/s 72 times, 9 m/s 85 times, 10 m/s 48 times, and 11 m/s 9 times during a given period. Find the mean, variance and standard deviation.
3. Evaluate the probability density function of Weibull distribution for $c = 1$ for $u = 0.1, 0.2, 0.4, 0.6, 0.8, 1.0, 1.2, 1.4, 1.6,$ and 1.8 m/s if $k = 3.2$ and 0.8 . Also plot the density function $f(u)$ versus u for both the values of k in a same plot.
4. Weibull parameters at a given site are $c = 7$ m/s and $k = 2.6$. About how many hours per year will the wind speed be between 8.5 and 9.5 m/s? About how many hours per year will the wind speed be greater than 10 m/s? About how many hours per year will the wind speed be greater than 20 m/s?
5. A potential wind farm site is characterized by the *Weibull parameters* $C = 9$ m/s and $k = 2.3$. The rated power output of the machine is 250 kW at a rated wind speed (UR) of 12.4 m/s at hub height. Assume $UC = 0.5$ UR and $UF = 2$ UR. Estimate the annual energy production by the WEG assuming 100% grid availability and 100% machine availability.

Suggested reading references

1. Jain P. Wind Energy Engineering. McGraw-Hill, New York, 2011
2. Jha AR. Wind Turbine Technology. CRC Press, Taylor & Francis Group, 2011
3. Johnson GL. Wind Energy Systems (Electronic Edition), Prentice Hall Inc, 2006
4. Mathew S. Wind Energy: Fundamentals, Resource Analysis and Economics, Springer, 2006.
5. Burton T. Sharpe D. Jenkins N. Bossanyi E. Wind Energy Handbook. John Wiley, 2001

DRE 104: WIND AND HYDRO ENERGY

UNIT-2: AERODYNAMICS OF WIND TURBINE

UNIT STRUCTURE

2.0 INTRODUCTION

2.1 AIRFOIL, LIFT AND DRAG CHARACTERISTICS

2.2 AERODYNAMIC THEORIES

2.2.1 BETZ COEFFICIENT

2.2.2 AXIAL MOMENTUM THEORY

2.2.2.1 MAXIMUM ATTAINABLE POWER COEFFICIENT

2.2.3 BLADE ELEMENT THEORY

2.2.4 STRIP THEORY OR BLADE MOMENTUM THEORY

2.2.5 ROTOR DESIGN PARAMETERS

2.2.6 DESIGN PROCEDURE

2.2.7 LINEARIZATION TECHNIQUES

2.3 WIND-TURBINE PERFORMANCE

2.3.1 POWER COEFFICIENT (CP) AND TIP SPEED RATIO (λ) PERFORMANCE

2.3.2 TORQUE COEFFICIENT (CQ) AND TIP SPEED RATIO (λ)

2.3.3 THRUST COEFFICIENT (CT) AND TIP SPEED RATIO (λ)

2.3.4 STALL AND PITCH REGULATION

Objectives

A wind turbine is a device that extracts the kinetic energy from wind and converts it into mechanical energy. Therefore power production from wind turbine depends on the interaction between the wind turbine rotor and the wind. So, the major aspects of wind turbine performance like power output are determined by the aerodynamic forces generated by the wind. These can only be understood with a deep comprehension understanding of the aerodynamics of steady state operation. Accordingly, this unit objective is to understand the basis of the aerodynamics mainly of HAWTs and the design methods based on various theories and to find out the best possible design parameters.

INTRODUCTION

The primary application of wind turbines is to extract energy from the wind. Hence, the aerodynamics is a very important aspect of wind turbines. The most common types of turbine are the horizontal axis wind turbine (HAWT). It is a lift based wind turbine with very good performance, accordingly it is a popular for commercial applications. In the latter part of the 20th century, the Darrieus wind turbine was another popular lift based alternative but it is rarely used today. The Savonius wind turbine is the most common drag type turbine, despite its low efficiency it is used because it is simple to build and maintain and very robust. However, in this unit, our discussion will be focused only on HAWT related issues. The kinetic energy extracted from the wind is influenced by the geometry of the rotor blades. Determining the aerodynamically optimum blade shape, or the best possible approximation to it, is one of the main tasks of the wind turbine designer.

This unit deals with the analytical approach for the analysis of horizontal axis wind turbines and the performance prediction of these machines. The analysis of the aerodynamic behavior of wind turbines can be started without any specific turbine design just by considering the energy extraction process. A simple model, known as actuator disc model (Betz maximum power coefficient calculation), can be used to calculate the power output of an ideal turbine rotor. Additionally more advanced methods including axial momentum theory (AMT), blade element theory (BET) and finally blade element momentum (BEM) theory are introduced in the discussion. The momentum theory and blade-element theory are used to outline the governing equations for the aerodynamic design and power prediction of a HAWT rotor. Momentum theory analyses the momentum balance on a rotating annular stream tube passing through a turbine and blade-element theory examines the forces generated by the airfoil lift and drag at various sections along the length of the blade. At the end, blade element momentum theory combines with AMT and BET methods to analyze the aerodynamic performance of a wind turbine.

2.1 AIRFOIL, LIFT AND DRAG CHARACTERISTICS

An airfoil is a surface over air flows. An airfoil or aerofoil is the shape of a wing or blade of a propeller, rotor or turbine or sail (Fig 1). An airfoil-shaped body surface over fluid flows and produces the aerodynamic force. This aerodynamic force is the resultant of two forces: Lift and Drag. The force component perpendicular to the direction of motion is called lift. The force component parallel to the direction of motion is called drag. The lift and drag force purely depends on the shape of the airfoil. However, not only on airfoils, but on all bodies, if placed in a uniform flow, a force is exerted, of which the direction is not parallel to the direction of undisturbed flow. In case of irregular shape body, the drag force is much higher than the lift force, and that's why it does not float and comes back to ground immediately if allow to fall from certain height. Whereas a thin paper or leaf float for certain period of time and then comes back to ground.

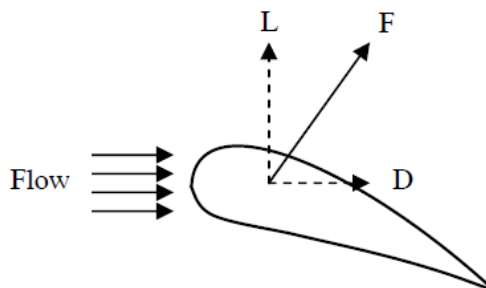

Figure 1: Lift and drag force action on an airfoil

The existence of the lift force depends upon laminar flow over the airfoil, which means that the air flows smoothly over both sides of the airfoil. If turbulent flow exists in place of laminar flow, there will be little or no lift force. Due to the typical curvature of the blade, air passing over the upper side has to travel more distance per unit time than that passing through the lower side (Fig2 and 3A). Thus the air particles at the upper layer move faster. In physical meaning, the flow on a body (such as an airfoil) is caused by the changes in the flow velocities (and direction) around the airfoil. On the upper side of the air foil, the velocities are higher than the bottom side (Fig 3A). The results is that the pressure on the upper side is lower than the pressure on the bottom side and hence the creation of the force F (Fig 3B).

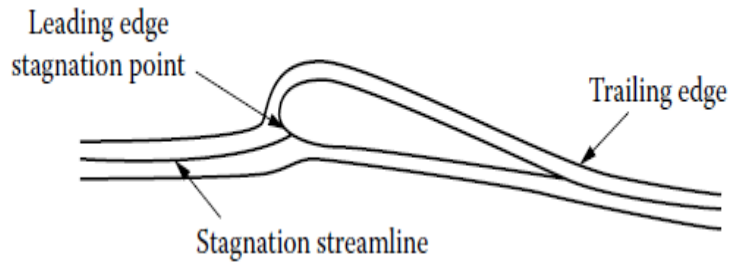

Figure 2: Trailing edge and leading edge of an airfoil

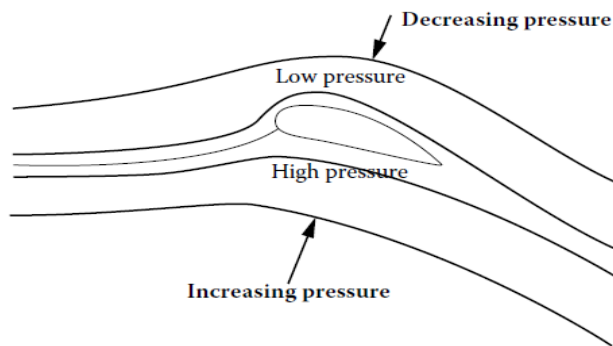

Figure 3A: Physical explanation for the lift force

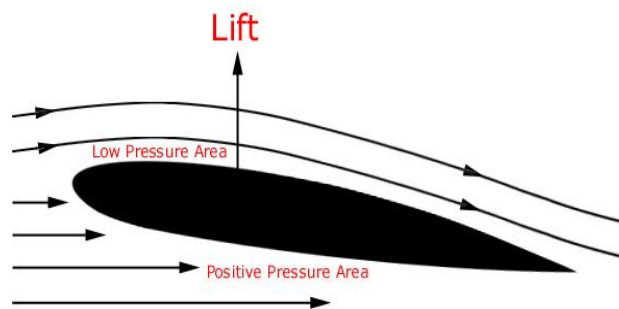

Figure 3B: Lift force acts over an airfoil

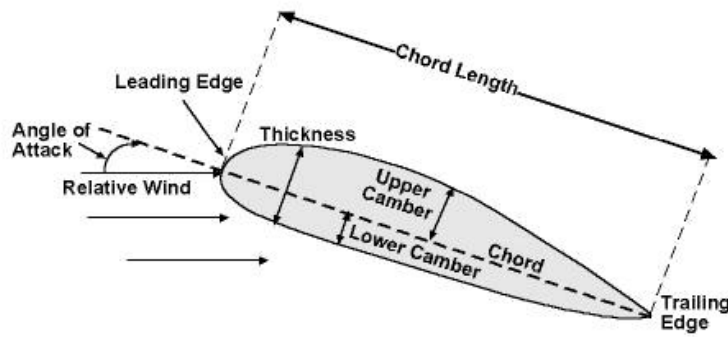

Figure 4: Different sections of an airfoil

In describing the lift and drag properties of different airfoils, reference is usually made to the dimensionless lift and drag coefficients, which are described as;

$$\text{Lift coefficient } C_l = \frac{L}{\frac{1}{2} \rho V^2 A}$$

$$\text{Drag coefficient } C_d = \frac{D}{\frac{1}{2} \rho V^2 A}$$

Where, L and D are the lift and drag force, ρ is the density of air (kg/m^3), V is the undisturbed wind speed (m/s) and A is projected blade area ($\text{Chord} \times \text{length}$) (m^2). These lift and drag coefficient are measured in wind tunnel for a range of angle of attack (α). Angle of attack is defined as the angle between the direction of the undisturbed wind speed and a reference line of the air foil (Fig 4). For a curved plate, the reference line is simply the line connecting the leading and trailing edge, while for an airfoil it is the line connecting the trailing edge with the centre of the smallest radius of curvature at the leading edge.

Lift and drag forces experienced by an airfoil is influenced by the angle of attack. Fig. 5 illustrates the effect of angle of attack on the lift coefficient of an airfoil. At lower angles of attack, the lift force increases with the increase of α . The lift reaches its maximum at certain α for an airfoil (120 in this example) and then decreases rapidly with further increase in α . This is because, at high angles of attack, the airflow enters an excessively turbulent region and the boundary layers get separated from the airfoil. At this region, lift force decreases and drag force is rapidly built up, resulting in the stall of the blade.

The values of lift coefficient (C_l) and drag coefficient (C_d) of a given airfoil vary with the wind speed, or particularly with the Reynolds number. The Reynolds number is a crucial dimensionless parameter is defined as $Re = V \times c / \nu$, where V is the undisturbed wind speed, c the characteristics length of the body (here the chord of the airfoil) and ν is the kinematic viscosity of the fluid (for air at 200C it is $15 \times 10^{-6} \text{ m}^2/\text{s}$). We can observe the $C_l - \alpha$ and $C_l - C_d$ characteristics for different values of Reynolds number at Fig 5.

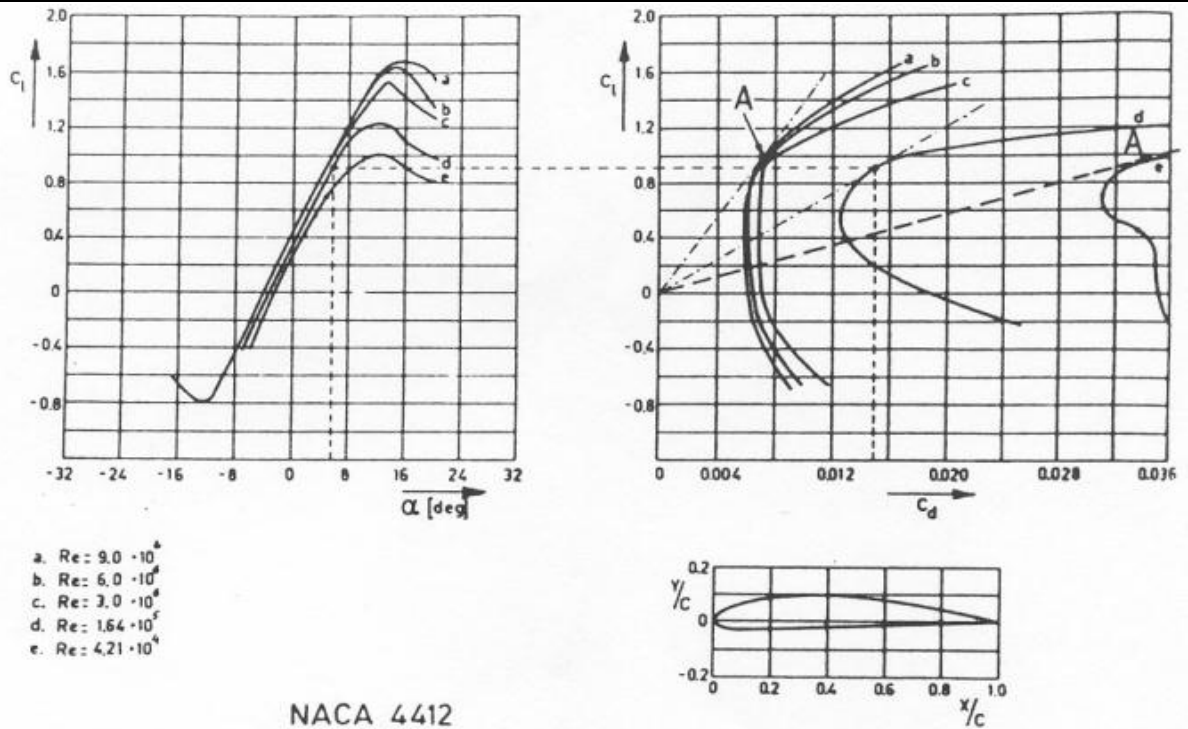

Figure 5: Lift and drag characteristics of NACA 4412 airfoil

Table 1: Typical values of drag-lift coefficient ratio, angle of attack and C_l for various curvatures

Type of airfoil	C_d/C_l	Angle of attack(θ)	C_l
Flat plate	0.1	5	0.8
Curved plate (10% curvature)	0.02	3	1.25
Curved plate with tube on concave side	0.03	4	1.1
Curved plate with tube on convex side	0.2	14	1.25
Air foil NACA 4412	0.01	4	0.8

Now, we will assume the $C_l - \alpha$ and $C_l - C_d$ characteristics for a proper (particular) value of Reynolds number. The tangent to the $C_l - C_d$ curve drawn from the origin indicates the angle of attack with the minimum C_d/C_l ratio. This ratio strongly determines the maximum power coefficients that can be reached, particularly at high tip speed ratios. We will elaborate this concept in the later sections. Here, we also must remember that in wind energy conversion systems, the blade profile must have the minimum drag coefficient or C_d/C_l ratio must be as minimum as it can be to obtain the maximum lift. The optimum value of angle of attack, and the lift coefficient (C_l) and minimum C_d/C_l ratio are important parameters in the design process. Table 1 shows the variation of all these parameters for various airfoil shapes. Fig 6 provides a better representation how wind flow creates the lift force and blades rotates due to this force.

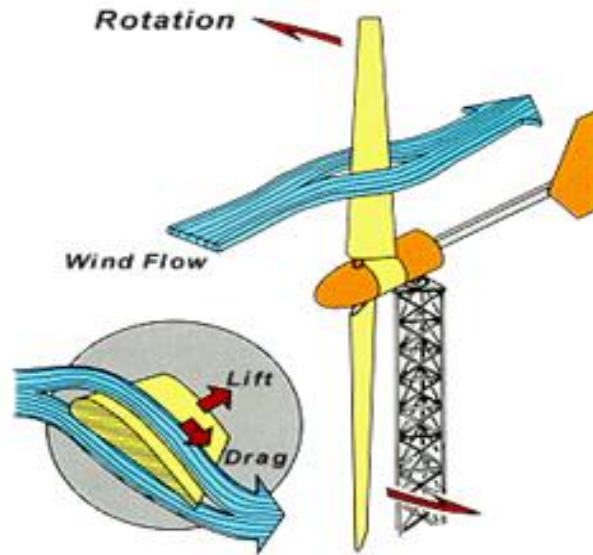

Figure 6: Principle of aerodynamic lift on wind turbine blade rotation

2.2 AERODYNAMIC THEORIES

Different theories are proposed to analyze the aerodynamics of wind turbines. These theories provide an insight to the behavior of the rotor under varying operating conditions. Let us discuss some of the fundamental theories among them, applicable to HAWT. We will start our discussion on Betz maximum power coefficient calculation and then will proceed to advanced methods like axial momentum theory (AMT), blade element theory (BET) and finally blade element momentum (BEM) theory. The BEM model is used as a tool for performance analysis due to its simplicity and can be readily implemented. Most wind turbine design codes are based on this method. Accordingly, this unit explains the aerodynamics of HAWTs based on a step-by-step approach starting from the simple Betz maximum power coefficient calculation (actuator disk model) to more complicated and accurate BEM method.

The basic of BEM method assumes that the blade can be analyzed as a number of independent elements (chord length, blade setting angle, flow angle) along the length of the blade. The thrust and torque force acting on the blade element is determined by performing the momentum balance for an annular control volume containing the blade element. Then the aerodynamic forces on each element are calculated using the lift and drag coefficient from the empirical two-dimensional wind tunnel test data at the geometric angle of attack of the blade element relative to the local flow velocity. Though the BEM theory-based methods are quite reasonable tool for designer, but they are not suitable for accurate estimation of the wake effects, the complex flow such as three-dimensional flow or dynamic stall because of the assumptions being made. However, these all complex issues are not purview of our present discussions.

2.2.1 BETZ COEFFICIENT

The power available from the wind is calculated in the earlier section and the value is

$$P = \frac{1}{2} \rho A V^3$$

Now the question is it possible to extract this complete amount of energy which is available in the air stream into mechanical forms of energy or not. If we could transform all the energy which is available in the flowing air stream that would mean, we could extract the complete kinetic energy of the air stream. Or, the wind speed after crossing the conversion device (wind rotor) will be zero. However, in real practice, it does not occur in this fashion. Or, it seems, there will be some optimum value up to which energy can be extracted from the wind. What is the maximum theoretical efficiency that can be extracted from the wind turbine? Albert Betz, a German physicist, in 1926 had established a limit for the maximum power coefficient for an ideal wind rotor. Betz calculated this value and found that the maximum power coefficient (CP) value is 16/27. This is known as Betz limit or maximum power coefficient. Hence, ideally the maximum power available from wind will be

$$P = \frac{1}{2} \rho A V^3 C_P$$

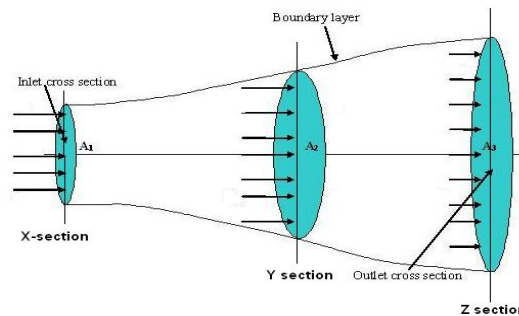

Figure 7: Velocity profile of airstream at three different sections

The Betz limit or maximum power efficient calculation is a very simple calculation and can be extended to other kinds of cases where power is extracted from even tidal or river sources. In this calculation, we assume

- All air that enters at A1 leaves from A2. Fluid flow is streamlined and so there is no loss of mass from the surface of the control volume.
- Fluid is incompressible, that is, there is no change in density.
- Fluid is non-viscous medium
- All the flow is along streamlines or axial flow.-, or no tangential component of the flow

We are considering three different sections with different velocity profile; X- where undisturbed air stream, Y- air-stream on the rotor and Z- far behind the rotor. Here V is the undisturbed wind speed, U is the axial velocity through the rotor and U2 is axial velocity in fully developed wake far behind the rotor.

Section	X	Y	Z
Velocity	V	U	U2
Area	A1	A	A2
Density	ρ_1	ρ	ρ_2

Now, we can write from the continuity equation, the mass flow rate is constant in all the three different sections;

Or
$$\dot{m} = \rho_1 A_1 V = \rho A U = \rho_2 A_2 U_2$$

Now applying Newton's second law, force (rate of change of momentum) exerted on rotor by wind will be

$$F = \dot{m} \Delta U = \dot{m}(V - U_2)$$

And the power (rate of change of kinetic energy) extracted by the rotor will be

$$P = \frac{1}{2} \dot{m}(V^2 - U_2^2)$$

The work done by the force due to pressure difference is equal to the change in kinetic energy at the rotor; the force does work at velocity U . Hence, we can write,

$$P = F \times U$$

Substituting the earlier two relations in this equation, we can obtain

$$\frac{1}{2} \dot{m}(V^2 - U_2^2) = \dot{m}(V - U_2) \times U$$

$$U = \frac{V + U_2}{2}$$

Or, the axial velocity acts on the rotor, is the average velocity of undisturbed wind speed and wake velocity at far behind the rotor.

We can also do some more simplification on the force equation;

$$F = \dot{m}(V - U_2) \rho A U (V - U_2) = \rho A \left(\frac{V + U_2}{2} \right) \times (V - U_2)$$

$$\text{Or } F = \frac{1}{2} \rho A V^2 (1 - K^2)$$

Where, $K = U_2/V$, is the ratio of undisturbed wind speed and wind speed after crossing the rotor. This ratio obviously will be lower than one, as the wake velocity will be lesser than the undisturbed wind speed.

Similarly, we can simplify the power equation;

$$\begin{aligned} P &= \frac{1}{2} m (V^2 - U_2^2) \\ &= \frac{1}{2} \rho A U (V^2 - U_2^2) \\ &= \frac{1}{2} \rho A \left(\frac{V + U_2}{2} \right) \times (V^2 - U_2^2) \\ &= \frac{1}{4} \rho A V^3 (1 + K)(1 - K^2) \end{aligned}$$

$$C_P = \frac{\text{Output power/area}}{\text{Input power/area}}$$

Now, we can easily obtain the power coefficient

$$\begin{aligned} C_P &= \frac{\frac{1}{4} \rho V^3 (1 + K)(1 - K^2)}{\frac{1}{2} \rho_1 V^3} \\ C_P &= \frac{1}{2} \left(\frac{\rho}{\rho_1} \right) \times (1 + K)(1 - K^2) \end{aligned}$$

Now, as we have considered that the fluid is in-compressible, so $\left(\frac{\rho}{\rho_1} \right) = 1$. Hence the power coefficient relation can be re-written as

$$C_P = \frac{1}{2} (1 + K)(1 - K^2)$$

So, the power coefficient depends on the ratio of undisturbed wind speed and the wind speed behind the rotor. Now to calculate the maximum power coefficient, we can use the condition

The Meaning of Betz Limit

Wind rotors in idealized conditions can extract, at most, 59.3% of energy contained in the wind. This is an important limit because it defines the upper limit of the efficiency of any rotor disk type energy extracting device that is placed in the flow of a fluid. A large fraction of the 59.3% of total wind energy that is extracted from wind is transferred to the turbine, but some of it is used to overcome viscous drag on blades and create vortices in the wake. Within the turbine, most of the energy is converted into useful electrical energy, while some of it is lost in gearbox, bearings, generator, power converter, transmission and others. Most practical rotors with three blades reach an overall maximum efficiency of about 35-45%.

$$\frac{dC_P}{dK} = 0$$

Or
$$\frac{dC_P}{dK} = \frac{d}{dK} [(1 + K)(1 - K^2)] = 0$$

After simplifying this relation, we will get $K = -1$ or $K = 1/3$. However, K cannot be negative, as this is the ratio of wind speed. Or the feasible solution is $K = 1/3$. So, at maximum power coefficient, the wind speed behind the rotor is one third of the undisturbed wind speed. Otherwise, we can conclude that two-third of the undisturbed wind speed can be extracted by the rotor. We can now calculate the maximum power coefficient value at $K = 1/3$; and it is found that the value of C_P at this condition is $16/27 = 0.593$. C_P is referred to as the Betz limit and states that the maximum power can extract from wind by an ideal rotor is 59.3%.

Example 1

A wind generator with an 8m diameter blade span has a rated wind speed (speed at which turbine generates rated output) of 7m/s, at this velocity, the turbine generator generates 3 kW electric power. Determine the efficiency of the turbine-generator set.

It is assumed that wind flow is steady, one dimensional and incompressible. The frictional effects are negligible and thus none of the incoming energy is converted to thermal energy.

The power available at the rated wind speed
$$P = \frac{1}{2} \rho A V^3$$

Here the density of air (ρ) is 1.12 kg/m³, area of the rotor is $\pi \times R^2$, where $R = 4m$ and the wind speed (V) is 7m/s.

So the input power available in the air stream

$$P = \frac{1}{2} \rho A V^3 = \frac{1}{2} \times 1.12 \times 3.14 \times 4^2 \times 7^3 = 9650.1 \text{ (W)}$$

The output power from the turbine-generator set at the given condition is 3 kW

So the efficiency of the turbine-generator set will be $\eta = \frac{\text{Output power}}{\text{Input power}} = \frac{3000}{9650.1} = 31.1\%$

2.2.2 AXIAL MOMENTUM THEORY

The conventional analysis of HAWT originates from the axial momentum concept introduced by Rankine (1865), which was further improved by Froude for marine propellers. The theory provides a relation between the forces acting on the rotor and the rotating fluid velocities and to predict the ideal efficiency of the rotor. Later on Betz included the rotational wake effects in this theory. Ideal flow conditions are considered for this analysis. The flow is assumed to be incompressible and homogeneous. The rotor is considered to be made up of infinite number of blades. Static pressures far in front and behind the rotor are considered to be equal to the atmospheric pressure. Frictional drag over the blades and wake behind the rotor are neglected.

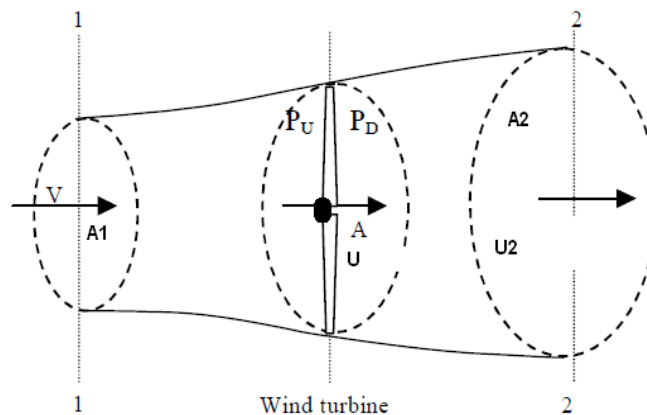

Figure 8: Velocity profile at three different sections

We are considering three different sections; 1- where undisturbed air stream, 2- air-stream on the rotor and 3- far behind the rotor. Here V is the undisturbed wind speed, U is the axial velocity through the rotor and U₂ is the axial velocity in fully developed wake far behind the rotor.

Section	1	2	3
Velocity	V	U	U ₂
Area	A ₁	A	A ₂
Density	ρ ₁	ρ	ρ ₂

We are assuming that the wind speed at the rotor is lesser than the undisturbed wind speed and related with the following relation

$$U = V(1 - \alpha)$$

At this stage, we introduce a parameter 'a', termed as the axial interference (induction) factor into our analysis. The axial induction factor 'a' indicates the degree with which the wind velocity at the upstream of the rotor is slowed down by the turbine and the value of 'a' is always less than one. From Betz maximum power coefficient calculation, we have already obtained the following relation

$$U = \frac{V + U_2}{2}$$

Thus the velocity of the wind stream at the rotor section is the average of the velocities at its upstream and downstream sides.

Now correlating these two relations, we can obtain

$$V(1 - \alpha) = \frac{V + U_2}{2}$$

$$U_2 = V(1 - 2\alpha)$$

So, the wind speed at the rotor (U) and the wind speed far behind the rotor (U₂) are related with the undisturbed wind speed (V) and the axial interference factor by the above expression.

As we have seen earlier, the power imparted to the wind turbine is due to the transfer of kinetic energy from the air to the rotor. Hence the power developed by the turbine due to this transfer of kinetic energy is

$$P = \frac{1}{2} \dot{m}(V^2 - U_2^2)$$

Where \dot{m} is the mass flow rate through the rotor.

Now we can simplify this relation by substituting the earlier velocities equations

$$P = \frac{1}{2} \dot{m}(V^2 - U_2^2)$$

$$P = \frac{1}{2} \rho A U (V^2 - U_2^2)$$

$$P = \frac{1}{2} \rho A V (1 - a) [V^2 - V^2 (1 - 2a)^2]$$

$$P = \frac{1}{2} \rho A V^3 4a(1 - a)^2$$

Now we can rewrite this power equation by introducing the power coefficient C_P .

$$P = \frac{1}{2} \rho A V^3 C_P$$

Hence, the power coefficient $C_P = 4a(1 - a)^2$

For C_P to be maximum, $\frac{dC_P}{da} = 0$

So, differentiating the earlier equation and equate to zero, we get the C_P maximum at $a = 1/3$.

Substituting this 'a=1/3' value in the power coefficient relation, we will get the maximum theoretical power coefficient of a horizontal axis wind turbine and that is 16/27 and this limit is known as the Betz limit. Hence, the maximum power is

$$P_{\max} = \frac{1}{2} \rho A V^3 \frac{16}{27}$$

It should be noted that, several assumptions are involved in this analysis. Some of these may be questionable, when we consider the real flow conditions around a wind turbine. For example, the practical rotor has finite number of blades and the aerodynamic drag and tip losses (losses at the tip of the blade due to the circulation) cannot be neglected. Further, the flow ahead and behind the rotor is not completely axial as assumed under the ideal condition. When the fluid applies torque to the rotor, as a reaction, rotational wake is generated behind the rotor. This will cause energy loss and reduce the peak power coefficient.

The ideal model of a completely axial flow before and after the rotor has to be modified when realizing that a rotating rotor implies the generation of angular momentum (torque). This means that in reaction to the torque exerted by the flow on the rotor, the flow behind the rotor rotates in the opposite direction. This rotation represents an extra loss of kinetic energy for the wind rotor, a loss that will be higher if the higher torque to be generated. We can also conclude that the slow-running wind rotors (windmill) has low

tip speed ratio and high torque experience more wake rotation losses than the high tip speed machine with low torque(wind electric generator).

Let us consider a ring of radius r and thickness dr (Fig 9). Then the cross-sectional area of the annular tube becomes $2\pi r dr$. The relative angular velocity changes from Ω to $\Omega + \omega$. Here ω is the induced tangential angular velocity of flow and Ω is the angular velocity of the rotor.

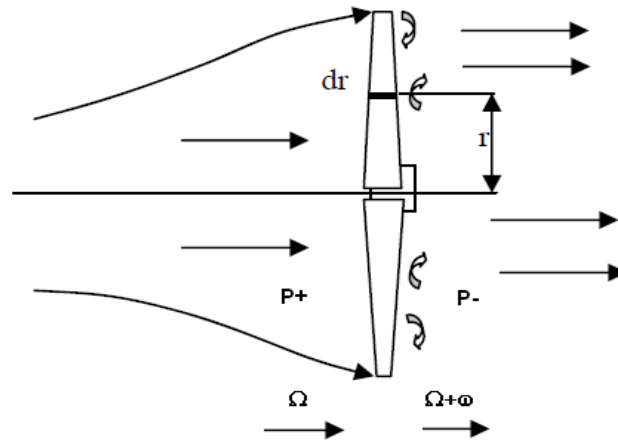

Figure 9: Rotational wake behind the rotor

Now, we can apply the Bernoulli's equation to derive the pressure difference over the blades. The pressure before the rotor is P^+ and behind the rotor is P^- . Therefore, the pressure difference between these two sections will be

$$P^+ - P^- = \frac{1}{2}\rho(\Omega + \omega)^2 r^2 - \frac{1}{2}\rho\Omega^2 r^2$$

$$dP = \frac{1}{2}\rho r^2 (\omega^2 + 2\omega\Omega)$$

$$dP = \frac{1}{2}\rho r^2 \times 2\omega \left(\Omega + \frac{\omega}{2}\right)$$

Now, the resulting thrust force experienced by the annular element may be expressed as

$$dT = dP \times 2\pi r dr \text{ [Force} \times \text{Area of the annular area]}$$

$$dT = \rho \omega r^2 \left(\Omega + \frac{\omega}{2} \right) 2\pi r dr$$

Considering the tangential flow behind the rotor, now we will introduce another factor termed as the tangential interference or induction factor a' in the analysis such that:

$$a' = \frac{\omega}{2\Omega}$$

Hence, the thrust equation can be written as

$$dT = \rho \frac{\omega}{2\Omega} 2\Omega r^2 \Omega \left(1 + \frac{\omega}{2\Omega} \right) 2\pi r dr$$

$$dT = 4a'(1+a') \frac{1}{2} \rho \Omega^2 r^2 2\pi r dr$$

We can also obtain the similar thrust equation from Betz calculation by introducing the axial interference factor

$$dT = \frac{1}{2} \rho A \times (V^2 - U_2^2) \text{ [Force} \times \text{annular area]}$$

$$dT = \frac{1}{2} \rho \times 2\pi r dr \times V^2 4a(1-a)$$

Now comparing both these two thrust equations, we can obtain:

$$4a'(1+a') \frac{1}{2} \rho \Omega^2 r^2 2\pi r dr = \frac{1}{2} \rho \times 2\pi r dr \times V^2 4a(1-a)$$

$$\frac{a(1-a)}{a'(1+a')} = \frac{\Omega^2 r^2}{V^2}$$

Here, we will introduce the concept of tip speed ratio (λ) for wind turbines. The tip speed ratio is defined as the ratio between the rotational speed of the tip of a blade and the actual wind velocity. If the velocity of the tip is exactly the same as the wind speed, then the tip speed ratio is 1. The tip speed of the blade can be calculated as Ω times R , where Ω is the rotor rotational speed in radians/second, and R is the rotor radius in meters. Therefore we can write:

$$\lambda = \frac{\Omega R}{V}$$

Now, if we calculate the tip speed ratio, along the length of the blade, then it is called local tip speed ratio. The local tip speed ratio is defined as;

$$\lambda(r) = \Omega r / V$$

Where r is the point at the blade, where the tip speed ratio is calculated. Now the local tip speed ratio and tip speed ratio is related with the following relation.

$$\lambda(r) = \lambda(r/R)$$

Now, we can write the above relation in terms of local tip speed ratio and flow parameters (axial and tangential). We will use this relation in later section.

$$\lambda_r^2 = \frac{a(1-a)}{a'(1+a')}$$

Apart from the above expression for the thrust on the rotor, it is possible to derive a relation for the torque exerted on the rotor. This is achieved by realizing that the conservation of angular momentum; which implies that the torque exerted must be equal to the angular momentum of the wake. The torque equation can be written as follows

$$dQ = \rho AU \times \omega r \times r; \text{ (mass flow rate} \times \text{linear velocity} \times \text{distance at which it is acting)}$$

$$dQ = \rho \times 2\pi r dr \times V(1-a) \times \frac{\omega}{2\Omega} \times 2\Omega r \times r$$

$$dQ = 4a'(1-a) \times \frac{1}{2} \rho V \Omega r \times 2\pi r dr \times r$$

The power developed by the rotor is the product of this annulus torque and angular velocity, integrated over the total blade span. The power is given by $dP = \Omega \times dQ$; so the total power is equal to

$$P = \int_0^R \Omega \times dQ$$

Here, we can note that the thrust and torque equation has been calculated based on the annular ring of radius r . So when we want to calculate the total power generation, it is required to consider the total blade length. And that's why we are integrating from 0 to R (R is the radius of the rotor) to obtain the total power.

Now we are substituting the torque relation in the integration and manipulated the relation to find out some simpler form of relation

$$P = \int_0^R \Omega \times dQ$$

$$P = \int_0^R 4a'(1-a) \times \frac{1}{2} \rho V \Omega r \times 2\pi r \, dr \times r \times \Omega$$

Now, we want to do some manipulation on the limit of integration by considering the local tip speed ratio relation; ($\lambda_r = \lambda(r/R)$);

$$\text{At } r = 0, \lambda_r = 0 \text{ (Hub) and at } r = R, \quad \lambda_r = \lambda \text{ (Tip); } r = \frac{R\lambda_r}{\lambda} \text{ or } dr = \frac{R}{\lambda} d\lambda_r$$

Now substituting these all relations, the power equation can be rewritten as

$$P = \int_0^\lambda 4a'(1-a) \times \frac{1}{2} \rho V \Omega \left(\frac{R\lambda_r}{\lambda}\right) \times 2\pi \left(\frac{R\lambda_r}{\lambda}\right) \times \left(\frac{R}{\lambda} d\lambda_r\right) \times \left(\frac{R\lambda_r}{\lambda}\right) \times \Omega$$

$$P = 4\rho V \Omega^2 \pi \left(\frac{R}{\lambda}\right)^4 \int_0^\lambda a'(1-a) \times \lambda_r^3 \, d\lambda_r$$

$$P = \frac{1}{2} \rho AV^3 \frac{8}{\lambda^2} \int_0^\lambda a'(1-a) \times \lambda_r^3 \, d\lambda_r$$

Again, we know;
$$P = \frac{1}{2} \rho AV^3 C_P$$

So, the power coefficient (C_P) will be
$$C_P = \frac{8}{\lambda^2} \int_0^\lambda a'(1-a) \times \lambda_r^3 \, d\lambda_r$$

Now in order to optimize the power coefficient, it is required to maximize the following expression

$$f(a, a') = a'(1 - a) \quad [1]$$

We also know

$$\lambda_r^2 = \frac{a(1 - a)}{a'(1 + a')} \quad [2]$$

We can optimize the problem, by maximizing the equation 1 and still satisfying the equation 2. Since a' is a function of a , the expression in equation 1 will be maximize when $df/da=0$

By doing this exercise, we will obtain the following relation

$$a' = \frac{1 - 3a}{4a - 1}$$

Hence, this relation between the axial and tangential interference flow parameters satisfies the maximum power coefficient condition. From, this relation, we can also observe that $a=1/3$ (maximum power coefficient condition at axial momentum theory calculation), $a'=0$ or there is no tangential flow. It also proves that at this condition, the flow is purely axial, which was one of the assumption in axial momentum theory calculation.

Example 2

The Suzlon S.66/1250 model rated power output is 1.25 MW at rated wind speed of 12 m/s. The rotor diameter of the wind turbine is 66 meters and a rotational speed of 13.9-20.8 rpm. Calculate the tip speed ratio range in this case.

The angular speed range

$$\omega = 2\pi N = 2 \times 3.14 \times \frac{(13.9 - 20.8)}{60} = 1.46 - 2.18 \frac{\text{rad}}{\text{s}}$$

The range of its rotor's tip speed can be estimated as:

$$v = \omega R = [1.46 - 2.18] \times 33 = 48.18 - 71.94 \frac{\text{m}}{\text{s}}$$

Thus the range of its tip speed ratio in this case:

$$\lambda = \frac{\omega R}{V} = \frac{48.18 - 71.94}{12} = 4 - 6$$

2.2.2.1 MAXIMUM ATTAINABLE POWER COEFFICIENT

The maximum power coefficient (CP) for a horizontal axis type wind rotor has been found $16/27=0.593$ from axial momentum analysis. However, this is the power coefficient of an ideal wind rotor with an

infinite number of blades with zero-drag situation. In practice, there are three effects, which cause a further reduction in the maximum attainable power coefficient. The effects are;

- *The rotation of the wake behind the rotor*
- *The finite number of blades*
- *Cd/Cl ratio is not zero.*

Effect of wake rotation

The creation of the rotating wake behind the rotor can be understood from the Fig 10. The result is due to the rotation of the wake, implying extra kinetic energy losses and a lower power coefficient. The torque is produced by the forces acting on the blades in tangential direction multiplied by their corresponding distances from the rotor centre. These forces are the results of velocity changes of the air in tangential direction. The direction of the velocity change in the air is opposed to the direction of the forces acting on the blades. Since, the air has no tangential component in the undisturbed wind speed (before the rotor), the velocity changes means that behind the rotor the wake rotates in a direction opposite to that of the rotor. This wake rotation means a loss of energy because the rotating air contains kinetic energy. At low tip speed ratio and high torque applications, means large angular velocity component in the wake or loss of energy is more. Hence, at low tip speed ratio applications, there will be considerable deviation from the maximum power coefficient.

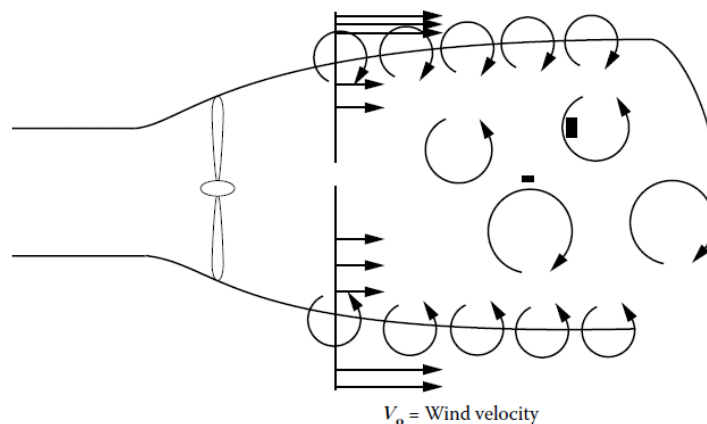

Figure 10: Turbulent wake state developed behind the rotor

Finite number of blades

A finite number of blades, instead of the ideal infinite number of blades, cause an extra reduction of power or affect the maximum power coefficient (Fig 11). The higher pressure at the lower side of the airfoil and lower pressure at the upper side are 'short circuited' at the tip of the blades; causing a cross flow around the tip, hence a decrease in pressure difference over the air foil. This phenomenon is called as tip loss (Fig 12). The length-width ratio of the blade determines the influence of this tip loss, the higher the ratio, the lower the tip loss. Hence, the tip loss affects the maximum power coefficient.

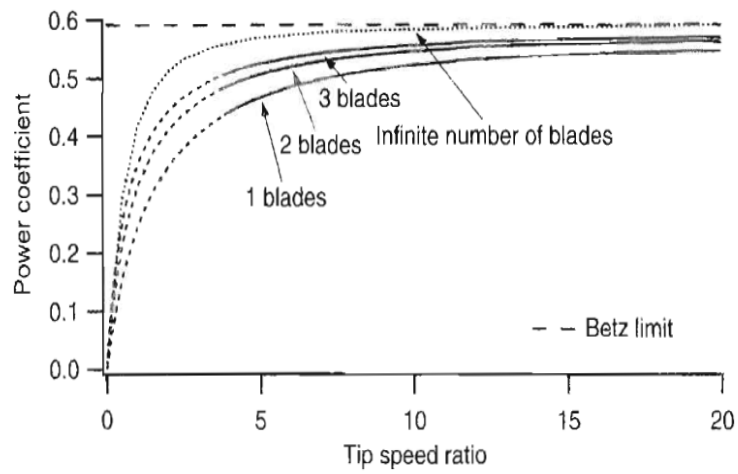

Figure 11: Maximum attainable power coefficient versus number of blades characteristics

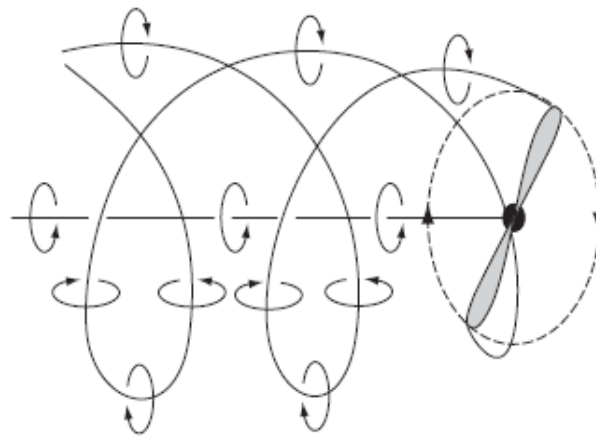

Figure 12: Generation of tip vortices of a HAWT

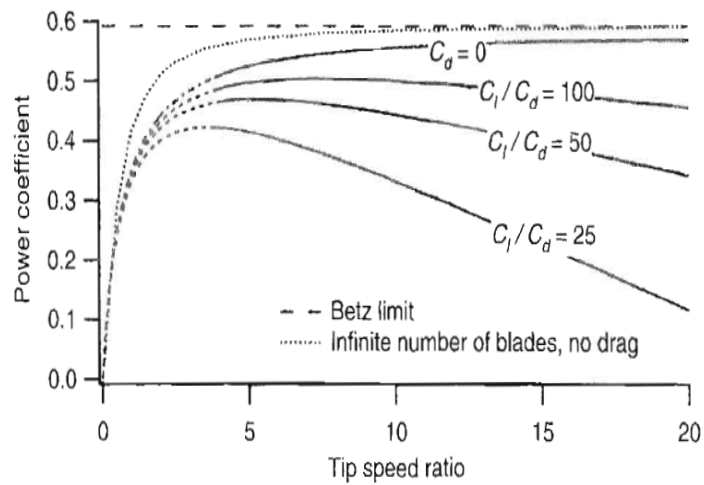

Figure 13: Maximum attainable power coefficient versus C_l/C_d ratio characteristics

The last effect is the drag of the profile, characterized by the Cd/Cl ratio of the air foil. The drag coefficient is a measure of resistance of the blades against moving through the air. The Cd/Cl ratio determines the losses due to this resistance (Fig 13).

2.2.3 BLADE ELEMENT THEORY

In the last section, we have done a detailed discussion on axial momentum theory. In axial momentum theory, we found the relation between the flow parameters (axial and tangential). However, we have not discussed or got any information related to the blade characteristics or design aspects of the rotor. These all aspects will be discussed in Blade element theory. However, before going into the details of blade element theory, the following assumption has to be considered.

- There is no interference exists between two adjacent blades, i.e. what happens at one element cannot affect the others.
- Forces acting on an elemental blade profile is solely depends on the lift and drag characteristics.

Blade element theory was initially proposed by Froude and Taylor. In this approach, it is considered that the blades are made up of a number of small strips (segments) along the length of the blade. The strips have infinitesimal thickness. These strips are aerodynamically independent and do not have any interference between them. Under this analysis, the lift and drag forces acting over the strip are estimated and integrated over the total blade length by incorporating the velocity terms, to obtain the total torque and power developed by the blade. This is further multiplied by the number of blades to get the total rotor torque and power. The blade element theory provides better understanding on the relationship between the airfoil properties, thrust experienced by the rotor and the power produced by it.

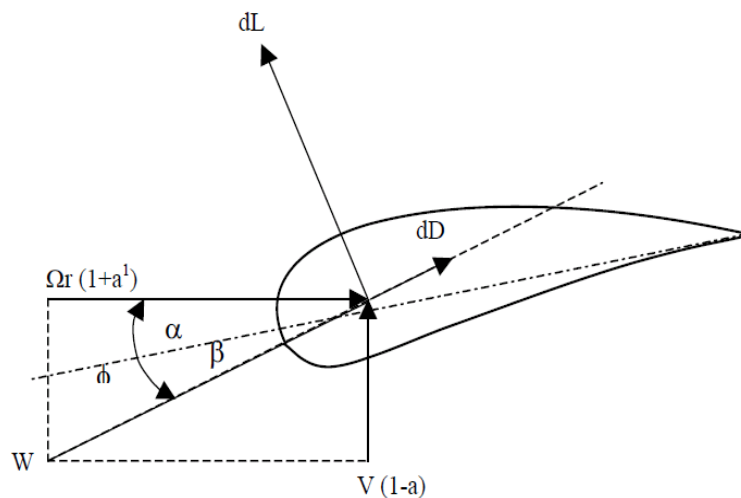

Figure 14: Force and velocity profile on an airfoil

The velocities and forces are acting on an infinitesimal blade element and shown in Fig. 14. The undisturbed wind velocity V is slowed down to $V(1-a)$ as it reaches the rotor. A velocity of $\Omega r(1+a')$ is experienced by the element due to the rotation of the blades and the wake behind the rotor. W

represents the resultant of these two velocities. Angle of attack (α) is the angle between the sectional chord and the relative velocity flow path. Blade setting angle (β) is the angle between the chord and the rotor plane (plane of rotation). Flow angle (ϕ) is the angle between the relative velocity of flow and rotor plane. And, again $\phi = \alpha + \beta$

Consider a blade divided into number of elements as shown in Figure 15A. Each of the blade elements will experience a slightly different flow as they have a different rotational speed (W), a different chord length (c) and a different blade setting (twist) angle (β). Blade element theory involves dividing up the blade into a sufficient number (usually between ten and twenty) of elements and calculating the flow at each one. Overall performance characteristics are determined by numerical integration along the blade span.

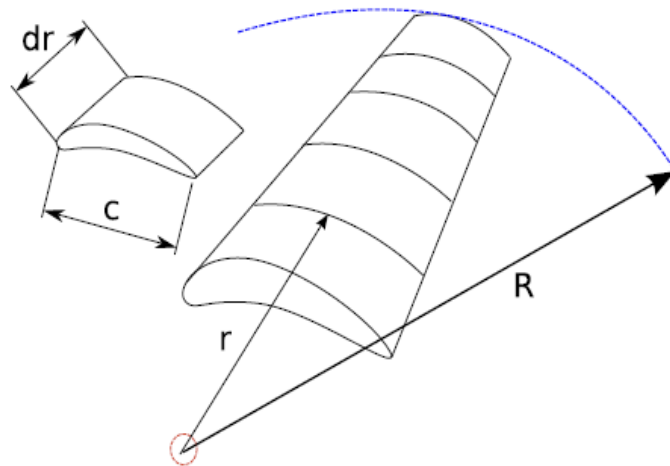

Figure 15A: Blade element model

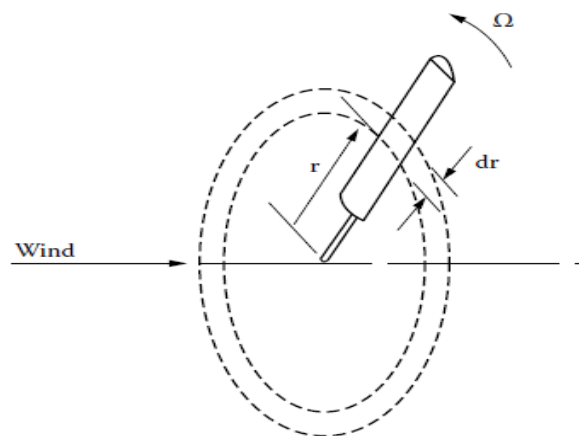

Figure 15B: Blade element model

Now the lift and drag forces acting on the infinitesimal airfoil section (Fig 15B) can be written as:

$$dL = C_L \times \frac{1}{2} \rho A W^2$$

$$dD = C_D \times \frac{1}{2} \rho A W^2$$

Where the area $A = C \times dr$; C is the airfoil chord, dr is the thickness of the section considered; C_L and C_d are the lift and drag coefficients (Fig15B).

From the Fig 14, we can observe that $\phi = \alpha + \beta$

And
$$\sin \phi = \frac{V(1 - \alpha)}{W}$$

$$\cos \phi = \frac{\Omega r(1 + \alpha')}{W}$$

Or we can write,
$$\tan \phi = \frac{(1 - \alpha) V}{(1 + \alpha') \Omega r}$$

Here, we can bring the tip speed ratio relation, what we obtained in the earlier section;

Local tip speed ratio (λ_r) = $\Omega r / V$

Hence the expression of the above relation will be changed to

$$\tan \phi = \frac{1 - \alpha}{\lambda_r (1 + \alpha')}$$

Now the lift and drag coefficients in the X-Y direction are

$$C_Y = C_l \cos \phi + C_d \sin \phi$$

$$C_X = C_l \sin \phi - C_d \cos \phi$$

The forces on the blade element are shown in Fig 14; note that by definition the lift and drag forces are perpendicular and parallel to the incoming flow. For each blade element with an elemental area dr , the thrust and torque force can be written as;

$$dT = B \times C \times \frac{1}{2} \rho W^2 C_y dr$$

$$dQ = B \times C \times \frac{1}{2} \rho W^2 [(C)_x \times r] dr$$

Where, B is the number of blades and C is the cord length. We can simplify these two relations by replacing the C_y and C_x component in terms of lift and drag coefficient obtained in the earlier cases.

The total torque developed by the rotor can be computed by integrating the elemental torque from the root to the tip of the blade. Rotor power is estimated by multiplying this torque by its angular velocity. The blade element theory can further be combined with the axial momentum theory for further understanding of the rotor behavior.

2.2.4 STRIP THEORY OR BLADE MOMENTUM THEORY

The strip theory or Blade Momentum Theory (BMT) is the combination of the momentum theory and the blade element theory. In axial momentum theory, we found the relation between the flow parameters; and in blade element theory, we have included the blade profile characteristic in our understanding. The strip theory combines both the flow parameters with the blade profile characteristics and provides us more insight to the design parameters of the wind turbine.

We have seen in axial momentum theory, the axial force or thrust on the annulus ring is

$$dT = 4a(1 - a) \frac{1}{2} \rho V^2 2\pi r dr$$

The similar thrust equation obtained from the blade element theory is

$$dT = B \times C \times \frac{1}{2} \rho W^2 C_y dr$$

Now combining these two thrust equations; we will obtain

$$4a(1 - a) \frac{1}{2} \rho V^2 2\pi r dr = B \times C \times \frac{1}{2} \rho W^2 C_y dr$$

$$4a(1 - a)V^2 = \frac{BC}{2\pi r} \times W^2 C_y$$

Here, we already know; $C_Y = C_l \cos\phi + C_d \sin\phi$ and if we consider the drag coefficient is not too high; then the relation can be approximated with $C_Y \approx C_l \cos\phi$.

Or the above relation can be rewritten as

$$4a(1 - a)V^2 = \frac{BC}{2\pi r} \times W^2 C_l \cos\phi$$

Now again, we know the following relation

$$\sin\phi = \frac{V(1 - a)}{W}$$

Or
$$\frac{V}{W} = \frac{\sin\phi}{(1 - a)}$$

Hence, by substituting these relations in the original expression, we will get the final expression

$$4a(1 - a) \left\{ \frac{\sin\phi}{(1 - a)} \right\}^2 = \frac{BC}{2\pi r} \times C_l \cos\phi$$

$$\frac{a}{(1 - a)} = \frac{\sigma C_l \cos\phi}{4 \sin^2\phi}$$

Where $\sigma = BC/2\pi r$ is known as local solidity ratio. Solidity ratio is defined as the fraction of the annular area in the control volume that is covered by the blades. In general, it is the ratio of total rotor plan-form area to total swept area. However, there is always an optimum solidity ratio for which the wind power intercepted and tip speed can be maximized, for example rotors with many blades have a higher solidity ratio and higher torque but their blades rotate at lower speed. So, depending on the applications and wind conditions the proper number of blades has to be selected.

Now let us consider the expressions for the elemental torque according to the above theories. The torque equation derived from the axial momentum theory is given by

$$dQ = u\rho \times 2\pi r dr \times \omega r \times r$$

And from blade element theory, the expression for torque is

$$dQ = BC \times \frac{1}{2} \rho W^2 [(C)_x \times r] \times dr$$

Now combining these two torque equations; we will get

$$u\rho \times 2\pi r dr \times \omega r \times r = BC \times \frac{1}{2} \rho W^2 [(C)_x \times r] \times dr$$

$$V(1 - a) \times \omega r = \frac{BC}{2\pi r} \times \frac{1}{2} W^2 C_x$$

Similarly like last time, if we consider the drag coefficient is not too high, then the relation can be approximated with $C_x \approx C_l \sin\phi$. Hence, by substituting this approximation, in the above expression, we will get the final expression as follows;

$$V(1 - a) \times \frac{\omega}{2\Omega} \times 2\Omega r = \frac{BC}{2\pi r} \times \frac{1}{2} W^2 C_l \sin\phi$$

$$\frac{a'}{(1 + a')} = \frac{\sigma C_l}{4 \cos\phi}$$

Hence, from the combination of axial momentum theory and blade element theory, we have obtained the following two relations.

$$\frac{a}{(1 - a)} = \frac{\sigma C_l \cos\phi}{4 \sin^2\phi}$$

$$\frac{a'}{(1 + a')} = \frac{\sigma C_l}{4 \cos \phi}$$

These two relation deals with the both the flow parameters (a and a'), and blade profile characteristics like, number of blades (B), chord length (C), lift coefficient(Cl) and the flow angle (ϕ) at a distance r along the length of the blade.

The blade momentum theory or strip theory discussed above deals with the basic aerodynamics of wind turbines. However, several assumptions are made in this analysis to represent ideal flow around the rotor. These theories are further modified by incorporating correction factors to reflect the practical flow conditions. Several other theories like vortex and cascade theories are also available for defining the aerodynamic properties of wind turbines.

2.2.5 ROTOR DESIGN PARAMETERS

In axial momentum theory discussion, we have evaluated the maximum power output condition in forms of relation between the axial and tangential flow parameters. The relation is

$$a' = \frac{1 - 3a}{4a - 1}$$

From the blade momentum theory, we have obtained the following two relations

$$\frac{a}{(1 - a)} = \frac{\sigma C_l \cos \phi}{4 \sin^2 \phi}$$

$$\frac{a'}{(1 + a')} = \frac{\sigma C_l}{4 \cos \phi}$$

Now we want to combine the first equation with the next two equations; and want to get the expression for chord length as a function of distance along the blade length. By doing these exercise, the chord length expression will be

$$C(r) = \frac{8\pi r}{(BC_l)(1 - \cos \phi)}$$

Earlier, we have obtained the following two relations

$$\tan\phi = \frac{1(1-a)}{\lambda_r(1+a')}$$

$$\text{or } \lambda_r = \frac{1(1-a)}{\tan\phi(1+a')}$$

Now we will use the following three relations to calculate the flow angle (ϕ) along the length of the blade.

$$\lambda_r = \frac{1(1-a)}{\tan\phi(1+a')}$$

$$\frac{a}{(1-a)} = \frac{\sigma C_l \cos\phi}{4\sin^2\phi}$$

$$\frac{a'}{(1+a')} = \frac{\sigma C_l}{4\cos\phi}$$

And the flow angle relation will be

$$\phi = \frac{2}{3} \tan^{-1}\left(\frac{1}{\lambda_r}\right)$$

Now, depending on the power to be developed based on the corresponding wind velocity at a site, the turbine radius can be computed by using the following relation.

$$P = \frac{1}{2} \rho A V_d^3 C_P$$

Where $A = \pi R^2$ is the swept area of the turbine, V_d is the designed wind speed and C_P is the power coefficient. Hence, the radius of the rotor will be

$$R = \sqrt{\frac{2P}{\rho \pi V_d^3 C_P}}$$

However, for conservative design, the power coefficient is generally considered around 0.4.

We used to divide the blade length into number of small segment at different position. And in one of this particular position, we used to calculate the tip speed ratio, which is known as local tip speed ratio. The local tip speed ratio relation can be written as;

$$\lambda_r = \lambda \left(\frac{r}{R} \right)$$

We can find the optimum C_l and α from the blade profile $C_l - \alpha$ and $C_l - C_d$ characteristics. Once the optimum angle of attack is obtained from these profile characteristics, we can easily obtained the blade setting angle at the different points along the blade length by the relation $\beta = \phi - \alpha$.

2.2.6 DESIGN PROCEDURE

Designing a wind energy conversion system is a complex process. In this section, a simple procedure for an approximate design of a wind rotor is discussed, based on the fundamental aerodynamic theories. Following steps are needed to perform for design of a wind turbine rotor.

Step I Determine the rotor diameter required from site conditions. The rotor radius can be calculated by using the following relation

$$R = \sqrt{\frac{2P}{\rho \pi V_d^3 C_P \eta}}$$

Where:

- R is the radius of the rotor
- P is the power output
- C_P is the expected coefficient of performance (0.4 for a modern three bladed wind turbine)
- η is the expected electrical and mechanical efficiencies (0.9 would be a suitable value)
- V is the designed wind velocity
- ρ is the air density at the site elevation and standard temperature.

Step II Divide the blade into number of elements or segments. Typically 10 to 20 elements would be used for better performance.

Step III Choose the tip speed ratio (λ_d) of the machine. This tip speed ratio is the designed tip speed ratio at which the CP value will be the maximum (at $C_p - \lambda$ characteristics). Design tip speed ratio depends on the application for which the turbine is being developed. For example, when we design the rotor for a wind pump which require high starting torque, low tip speed ratio is chosen. On the other hand, if our intention is to generate electricity, we require a fast running rotor and hence high tip speed ratio. For water pumping, we can use $1 < \lambda < 3$ (which provides high torque) and for electrical power generation can consider $4 < \lambda < 10$.

Step IV Determine the local tip speed ratio at each segment of the blades. The local tip speed ratio can be calculated by using the following relation.

$$\lambda_r = \lambda_d \left(\frac{r}{R} \right)$$

Step V Choose the number of blades (**B**), using Table 1, which is based on practical experience. Number of blades in a rotor is directly related to the design tip speed ratio. The higher the tip speed ratio, the lower would be the number of blades. Table 1 provides a guideline for choosing the number of blades based on the design tip speed ratio.

Step VI Select an aerofoil. For $\lambda < 3$, curved plates can be used rather than an aerofoil shape. Obtain and examine the lift and drag coefficient curves for the aerofoil in question. Note that different aerofoil can be used for different spans of the blade. A thick aerofoil can be selected for the hub section to provide greater strength. From the air foil $C_l - \alpha$ and $C_l - C_d$ characteristics, find out the optimum C_l at which C_d/C_l is minimum (this can be obtained from the $C_d - C_l$ characteristics of an airfoil by plotting a tangent to the curve from the origin as shown in Fig. 5.) and the angle of attack (α) at this optimum C_l value. This C_l and α will be used for the designed purpose.

Step VII Compute the flow parameter at the different segment of the blade length by using the following relation.

$$\phi = \frac{2}{3} \tan^{-1} \left(\frac{1}{\lambda_r} \right)$$

Step VIII Compute the blade setting angle at the different segment of the blade length by using the following relation.

$$\beta = \phi - \alpha$$

Step IX Compute the chord distribution of the aerofoil. There is no easily physically accessible way of doing this but a simplification way to calculate of an ideal blade is given by the following relation. This provides a moderately irregular shape of the chord length along the blade length.

$$C(r) = \frac{8\pi r}{(BC_l)(1 - \cos\phi)}$$

The essential outputs of a wind turbine design are the number of blades, the aerofoil shape, the chord distribution and the blade setting angle or twist distribution. The design procedure discussed above provides some simple way to do the calculation. Fig 16 represents the variation of flow angle and chord length at the different position along the length of the blade.

Table 1: Number of blades and Tip speed ratio

<i>Tip speed ratio (λ)</i>	<i>Number of blades (B)</i>
<i>1</i>	<i>8-24</i>
<i>2</i>	<i>6-12</i>
<i>3</i>	<i>3-6</i>
<i>4</i>	<i>3-4</i>
<i>More than 4</i>	<i>1-3</i>

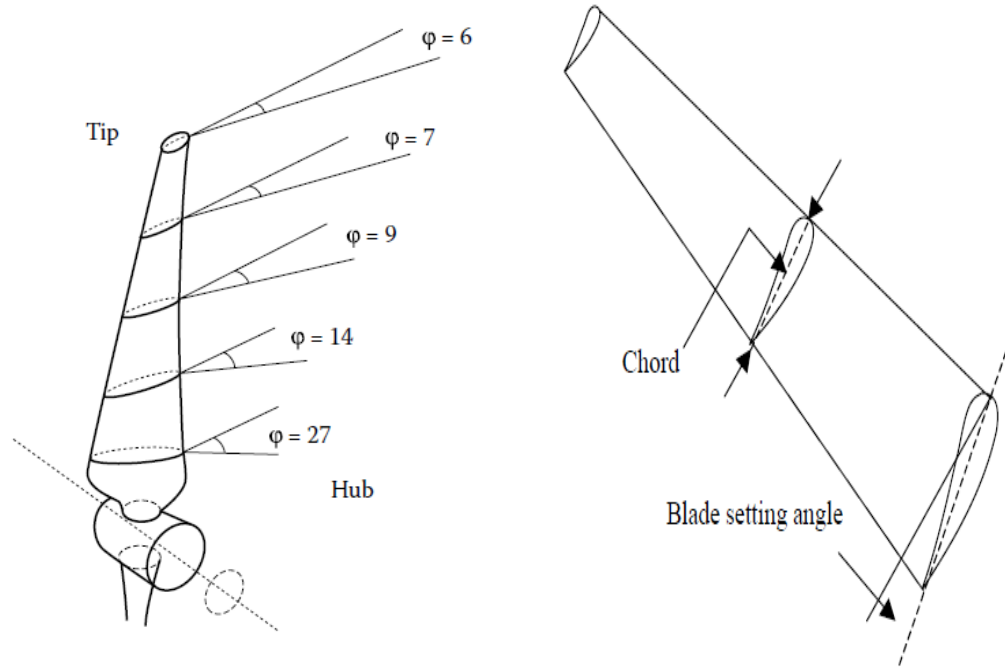

Figure 16: Flow angle and chord length variations at the different points along the length of the blade

The actual accurate design procedure is based on iteration process to find out the flow parameters and then to calculate all the other design parameters. Here, we shall not discuss in details, how to write the computer program for this purpose, but just outline the method. This is one of the common methods introduced by Wilson and Lissaman and used widely.

The procedure is to find out the of the axial and tangential interference factor for a number of blades positions r . As there is no analytical expression for calculation of the interference factor, we need to use an iteration method with the following steps.

Step I Choose a value for $r \rightarrow \lambda_r = \frac{r}{R} \lambda$

Step II Assume reasonable starting value for a and a' (i.e. $a=1/3$ and $a'=0$)

Step III Calculate ϕ with
$$\phi = \frac{\tan^{-1} \left(\frac{1-a}{1+a'} \right) 1}{\lambda_r}$$

Step IV Calculate β with $\beta = \phi - \zeta$

Step V Calculate C_l from C_l - α form C_l - C_d characteristics of the blade profile

Step VI Calculate the axial and tangential flow parameters by using the following relations

$$\frac{a}{(1-a)} = \frac{\sigma C_l \cos \phi}{4 \sin^2 \phi}$$

$$\frac{a'}{(1+a')} = \frac{\sigma C_l}{4 \cos \phi}$$

Step VII Compare the values of a and a' with the initial values and iterate until the desired accuracy obtained.

Step VIII Calculate the values of dT, dQ and dP for number of positions along the blade length.

Step VIII Calculate the total values of power, thrust and torque by doing the numerical integration.

Example 3

Design the rotor for an aero generator to develop 100 W at a wind speed of 7 m/s. NACA 4412 airfoil may be used for the rotor. Assume the design power coefficient as 0.4, combined drive train and generator efficiency 0.9 and the designed tip speed ratio is 4. Taking the air density as 1.224 kg/m³.

$$R = \sqrt{\frac{2P}{\rho \pi V_d^3 C_P \eta}}$$

The radius of the rotor will be

$$R = \sqrt{\frac{2 \times 100}{1.224 \times 3.14 \times 7^3 \times 0.4 \times 0.9}} = 0.65 \text{ m}$$

Here, the application of the aero-generator is to produce electricity. So, we prefer a low solidity rotor with minimum number of blades and working at high tip speed ratio. For aerodynamic and structural stability, a three bladed rotor is considered. Hence the numbers of blades are 3.

The available performance data of NACA 4412 airfoil shows that the minimum Cd/Cl of 0.01 is attained at an angle of attack of 40 and the corresponding lift coefficient (Cl) is 0.8. Hence the designed lift coefficient is 0.8 and the designed angle of attack is 40.

Now let us the blade length into 10 equal segments. So each segment will be 0.065m. Now we want to calculate the local tip speed ratio at each segment point by using the following relation.

$$\lambda_r = \frac{r}{R} \lambda$$

The various segment on the blade length will be; 0.065m, 0.13m, 0.195m, 0.26 m, 0.325m, 0.39m, 0.455m, 0.52m, 0.585m and 0.65m respectively. We will try to calculate all the design parameters at all these segments.

The local tip speed ratio at these segments will be

0.4, 0.8, 1.2, 1.6, 2.0, 2.4, 2.8, 3.2, 3.6 and 4.0

Now the flow angle at these 10 different segments can be calculated by using the following relation

$$\phi = \frac{2}{3} \tan^{-1} \left(\frac{1}{\lambda_r} \right)$$

So, the flow angle at the first segments will be

$$\phi_1 = \frac{2}{3} \tan^{-1} \left(\frac{1}{0.4} \right) = 45.5^\circ$$

Similarly, the other flow angles at the different segments can be calculated

34.20, 26.50, 21.30, 17.70, 15.10, 13.10, 11.60, 10.30, 9.40

Now the blade setting angle or twist of the blade along the blade length, can be calculated by using the following relation

$$\zeta = \phi - \zeta$$

Hence, the blade setting angle at the first segments will be

$$= 45.5 - 4 = 41.5^\circ$$

Similarly, the other blade setting angle at the different segments can be calculated and will be as follows;

$$30.20, 22.50, 17.30, 13.70, 11.10, 9.10, 8.60, 6.30, 3.40$$

Now the chord length along the blade length, can be calculated by using the following relation

$$C(r) = \frac{8\pi r}{(BC_l)(1 - \cos\phi)}$$

Hence, the chord length at the first segments will be

$$C_1 = \frac{8\pi \times 0.065}{3 \times 0.8} (1 - \cos 45.5) = 0.20 \text{ m}$$

Similarly, the other chord length at the different segments can be calculated and will be as follows;

$$0.24\text{m}, 0.21\text{m}, 0.19\text{m}, 0.16\text{m}, 0.14\text{m}, 0.12\text{m}, 0.11\text{m}, 0.099\text{m}, 0.091\text{m}$$

Now, we have calculated the blade setting angle or blade twist and chord length along the blade length, which will be required for designing the physical blade. It can be observed from the results that, to keep a constant angle of attack and thus the same lift throughout the blade, the chord and blade setting angle vary throughout the blade length.

2.2.7 LINEARIZATION TECHNIQUES

The chord length and blade setting angle or twist vary in a non-uniform manner along the blade length (Fig 17). Such blades are normally difficult to manufacture and lead to an uneconomic use of materials. In order to reduce, these problems, it is possible to linearize the chords and blade angles. This will result in a small loss of power. However, if this linearization has done sensible way, the loss of power can be minimized to a great extent.

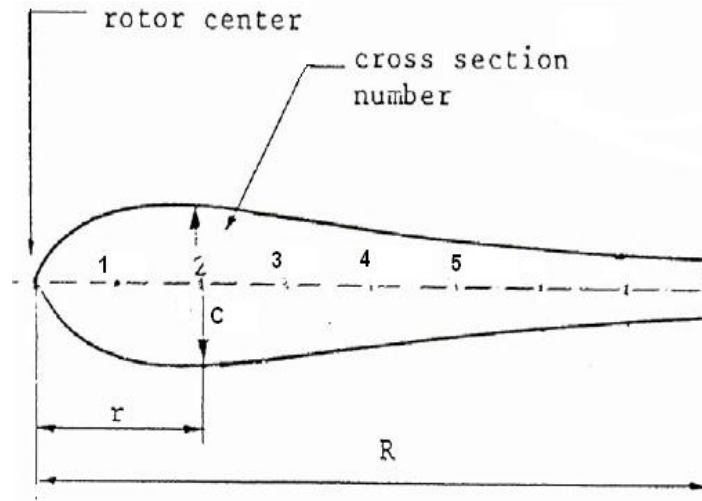

Fig 17 (a)

In considering such linearization, it must be realized that about 75% of the power that is extracted by the rotor from the wind, is extracted by the outer half of the blades. This is because that the blade swept area varies with the square of the radius, and also efficiency of the blade is less at smaller radius, where the local tip speed ratio is low. On the other hand, at the tip of the blade, the efficiency is low due to the tip losses. Hence, it is a sensible, if the linearization has done in between 50-90% of the radius. There are two types of linearization techniques.

- *Constant chord and linear twist*
- *Variable linear chord and linear twist*

Constant chord and liner twist

In this case, the lift coefficients vary along the blade length keeping the chord is constant. So the relation will be

$$C_l = C_l(\alpha)$$

Variable linear chord and linear twist

In this case, the lift coefficient kept constant (so the angle of attack) and the chord and blade twist varies linearly from the hub to tip of the blade.

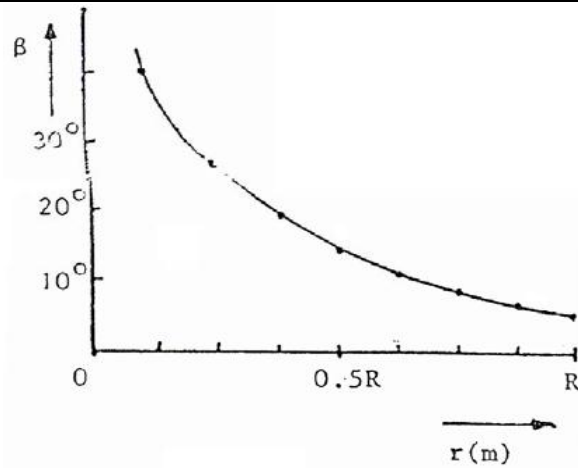

(b)

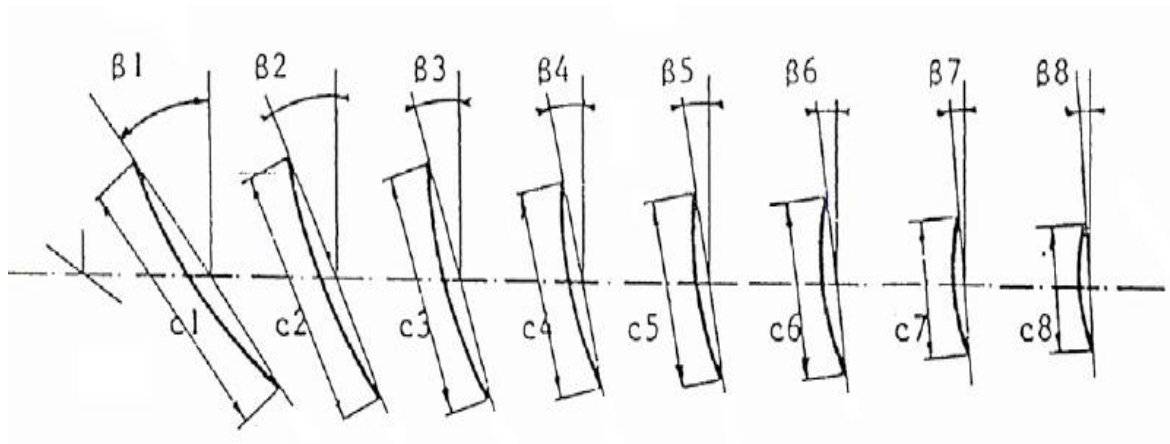

(c)

Figure 17: (a) Blade form, (b) twist and (c) cross section of the blade

Example 4

Find out the chord and blade angle at tip and hub of the blade by linearize the chord and blade angle in between 50-90% of the radius of the rotor of the example 3. Consider variable linear chord and linear twist technique.

From the example 3, we have obtained the radius of the rotor is 0.65 m. Here, the linearization needs to be done in between 50% to 90% of the radius.

Here, 50 % of the radius mean = $0.5 \times 0.65 = 0.325$ m and 90% of the radius mean = $0.9 \times 0.65 = 0.585$ m. Or the chord and blade angle need to be linearly twisted between 0.325 m and 0.585 m point on the blade length.

Now the chord and blade angle at these two points are (calculated in the earlier example)

$r(m)$	$C(m)$	$\beta(0)$
0.325	0.16	17.7
0.585	0.099	10.3

Now, we can linearize the chords and blade angles by writing these two parameters in the following way.

$$C = a_1 r + a_2$$

$$\beta = a_3 r + a_4$$

Where a_1 a_2 a_3 and a_4 are the coefficients. These coefficients can be easily determined as, we know the values of C and β at two different values of r .

$$0.16 = a_1 \times 0.325 + a_2$$

$$0.099 = a_1 \times 0.585 + a_2$$

$$17.7 = a_3 \times 0.325 + a_4$$

$$10.3 = a_3 \times 0.585 + a_4$$

The values of the coefficients are $a_1 = -0.235$, $a_2 = 0.236$; $a_3 = -28.46$, $a_4 = 26.95$

Now the linearize relation for chords and blade angle are

$$C = -0.235r + 0.236$$

$$\beta = -28.46r + 26.95$$

Now we can easily find out the chord and blade angle at hub and tip of the blade. These parameters will now linearly vary along the blade length. The ideal blade form and linearized blade form can be seen at Fig 18A. Similarly, the ideal twist and linearized twist along the blade length can be seen at Fig 18B.

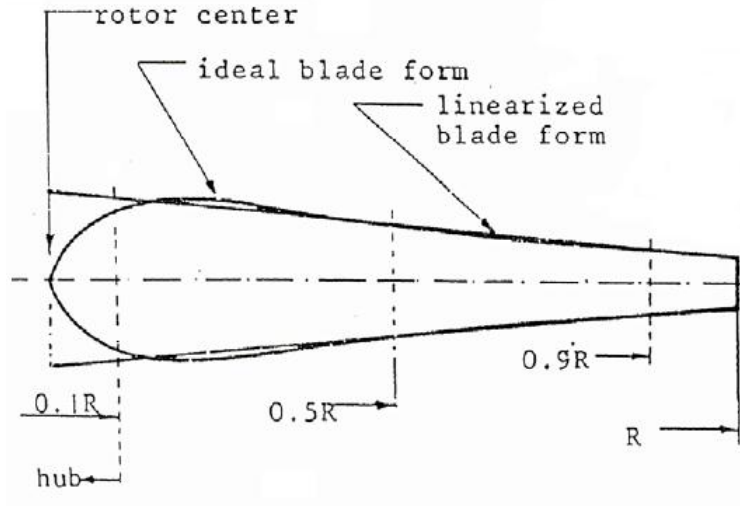

(a)

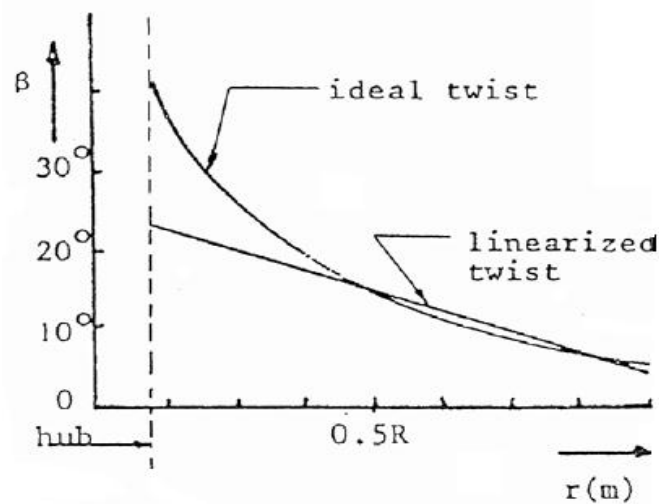

Figure 18: Idle and linearized (a) chord and (b) twist

2.3 WIND-TURBINE PERFORMANCE

The wind turbine performance can be characterized by parameters - power, torque and thrust and the variations of these parameters with wind speed. The power determines the amount of energy captured by the rotor; the developed torque determines the size of the gear box and connected generator driven by the rotor. The rotor thrust has great influence on the structural design of the tower. It is usually sensible to express the performance by means of non-dimensional characteristic performance curves from which the actual performance can be determined regardless of how the turbine is operated. It is usual, therefore, to present the power, torque and thrust coefficients as functions of tip speed ratio.

2.3.1 POWER COEFFICIENT (C_P) AND TIP SPEED RATIO (λ) PERFORMANCE CHARACTERISTICS

The power developed by a turbine is governed by the various design parameters. The usual method of presenting power performance is the non-dimensional $C_P - \lambda$ curve and the curve for a typical, modern, three-blade turbine is shown in Fig 19. It can easily observe from the Fig 19, that the maximum value of C_P is only 0.47, achieved at a tip speed ratio of 7, which is much less than the Betz limit. The discrepancy is caused, in this case, by drag and tip losses but the stall also reduces the C_P at low values of the tip speed ratio. Even with no losses included in the analysis, it will be difficult to reach Betz limit as the blade design will not be perfect.

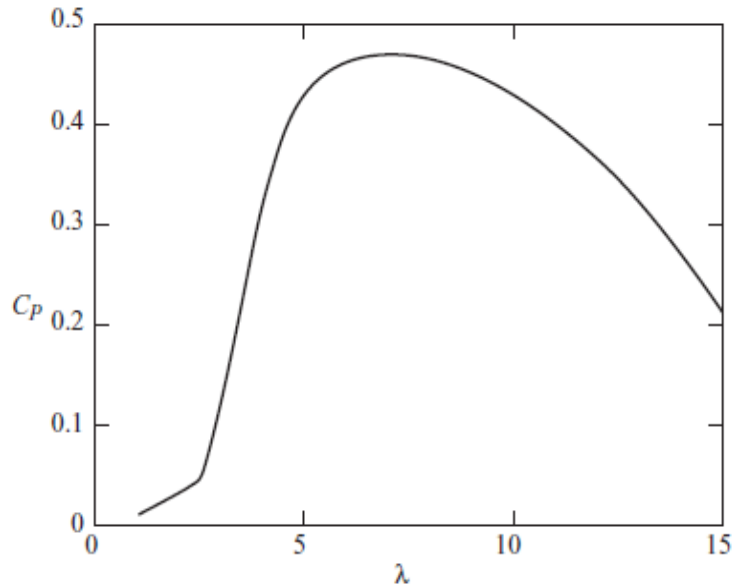

Figure 19: $C_P - \lambda$ performance curve of a modern three bladed turbine

2.3.2 TORQUE COEFFICIENT (C_Q) AND TIP SPEED RATIO (λ)

The torque coefficient is derived from the power coefficient, simply dividing by the tip speed ratio and so it does not provide any additional information about the turbine's performance. The principal use of the $C_Q - \lambda$ curve is for torque assessment purposes when the rotor is connected to a gear box and generator. The modern high speed turbines design for electricity generation always tries for as low torque as possible in order to have higher power coefficient. On the other hand, multi-bladed, high-solidity turbine, design for water pumping, rotates slowly and has a very high starting torque coefficient which is necessary for overcoming the torque required to start a positive displacement pump. The peak of the torque curve occurs at a lower tip speed ratio than the peak of the power curve.

2.3.3 THRUST COEFFICIENT (C_T) AND TIP SPEED RATIO (λ)

The thrust force on the rotor is directly applied to the tower on which the rotor is supported and so considerably influences the structural design of the tower. Generally, the thrust on the rotor increases with increasing solidity

2.3.4 STALL AND PITCH REGULATION

This section discusses the two principal means of limiting rotor power in high operational wind speeds - stall regulation and pitch regulation. Stall regulation provides the simplest means of controlling the maximum power generated by a turbine to suit the sizes of the installed generator and gearbox. This feature provides an element of passive power output regulation, ensuring that the generator is not overloaded as the wind speed increases. Ideally, the power should rise with wind speed to the maximum value and then remain constant regardless of the increase in wind speed; this is called perfect stall regulation. Stall control is a delicate process, both aerodynamically and electrically. In summary a stall-regulated wind turbine will run at approximately constant speed in high wind without producing excessive power and yet achieve this without any change to the rotor geometry.

The main alternative to such a stall regulated operation is pitch regulation. This involves turning the wind turbine blades about their long axis (pitching the blades) to regulate the power extracted by the rotor. In contrast to stall regulation, pitch regulation requires changes of rotor geometry by pitching the blades. This involves an active control system, which senses blade position, measures output power and instructs appropriate changes of blade pitch. The objective of pitch regulation is similar to stall regulation, to regulate the output power at high operational wind speeds.

Short type questions

- 1. What is the physical significance of axial and tangential interference factors?*
- 2. Draw the wind flow pattern and force acting on an air foil.*
- 3. Draw the CP- λ characteristics and briefly explain the physical significance for different values of axial interference factor.*
- 4. Define : Air foil, lift and drag force, tip speed ratio, solidity ratio, pitch regulation, angle of attack, blade setting angle, maximum power coefficient, Windmill and Wind electric generator, Blade linearization*
- 5. Draw the Cp- λ characteristics for wind mill and wind electric generator.*

Long type questions

- 1. Calculate the chord length and blade angle at eight different position along the blade length by using the following data*

Number of blades	4
Designed wind speed	6m/s
Power requirements	250 Watts
Designed tip speed ratio	4
CP (optimum)	0.42
Designed lift coefficient	1.1
Optimum angle of attack	40
Blade linearization	40-90% of radius

- 2. Derive the relationship between axial interference factor and tangential interference factor.*
- 3. Define Betz limit and derive the expression for CP from axial momentum theory.*
- 4. Discuss the theoretical simulation model for a designing a wind turbine rotor with a block diagram*
- 5. Briefly explain on formation of wake rotation behind the rotor.*

Suggested reading references

- 6. Jain P. Wind Energy Engineering. McGraw-Hill, New York, 2011*

7. *Jha AR. Wind Turbine Technology. CRC Press, Taylor & Francis Group, 2011*
8. *Johnson GL. Wind Energy Systems (Electronic Edition), Prentice Hall Inc, 2006*
9. *Mathew S. Wind Energy: Fundamentals, Resource Analysis and Economics, Springer, 2006.*
10. *Burton T. Sharpe D. Jenkins N. Bossanyi E. Wind Energy Handbook. John Wiley, 2001*

DRE 104: WIND AND HYDRO ENERGY

UNIT-3: WIND ENERGY CONVERSION SYSTEMS

UNIT STRUCTURE

INTRODUCTION

3.1 WIND ELECTRIC GENERATORS

3.1.1 TOWER, ROTOR, GEARBOX, POWER REGULATION, SAFETY

MECHANISM

3.1.1.1 TOWER

3.1.1.2 ROTOR

3.1.1.3 GEARBOX

3.1.1.4 POWER REGULATION

3.1.1.5 SAFETY MECHANISM

3.1.2 GENERATOR: INDUCTION AND SYNCHRONOUS GENERATOR

3.1.2.1 INDUCTION GENERATOR

3.1.2.2 SYNCHRONOUS GENERATOR

3.1.2.3 FIXED AND VARIABLE SPEED OPERATIONS

3.1.3 GRID INTEGRATION

3.2 WIND PUMPS

3.2.1 WIND POWERED PISTON PUMP, LIMITATIONS AND PERFORMANCE ANALYSIS

3.2.1.1 COUPLING OF PUMPS AND WIND ROTOR

3.2.1.2 PERFORMANCE ANALYSIS

3.2.1.3 LIMITATIONS OF WIND DRIVEN PISTON PUMPS

SUGGESTED READING REFERENCES

QUESTIONS

Objectives

Human efforts to harness wind for useful work date back to the ancient times to propel ships or boats, for grain grinding and water pumping. During its transformation from these crude and heavy devices to today's efficient and sophisticated machines, the technology has gone through various phases of development. The wind energy conversion systems (WECS) have transformed to various sizes, shapes and designs, to suit the applications for which they are intended from its earlier day's windmills to the modern multi MW range wind electric generator. Today, the single capacity turbine can generate 7.5 MW power. The efficient and reliable performance of the wind energy conversion system depends upon the careful design, crafting and integration of all its components. This unit discusses the various components of the wind energy conversion systems.

INTRODUCTION

The wind energy conversion system is a conversion device which converts the kinetic energy available in the wind to useful forms of energy like mechanical energy, electrical energy. The wind energy conversion systems (WECS) have transformed to various sizes, shapes and designs, to suit the applications for which they are intended from its earlier day's windmills to the modern multi MW range wind electric generator. Fig 1 presents a schematic diagram of wind energy conversion system.

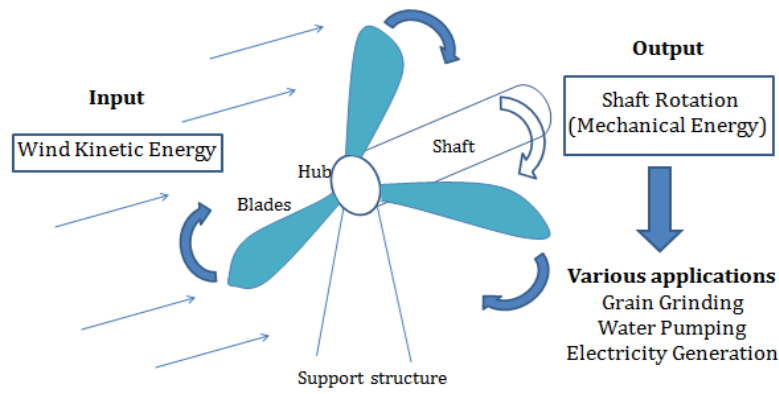

Figure 1: Schematic diagram of wind energy conversion system

Since ancient times, man has harnessed the power of the wind to provide motive power for transportation as evidenced by sails used to propel boats and ships. Similarly, in the history of food technology, the technique of grinding grain between stones to produce flour is ancient and widespread. Earlier, animal power and water power have been utilized for grinding/milling. Later, an important technological milestone was evolved when the power of the wind came to be utilized for this purpose. The wind energy conversion system in which the mechanical power of a rotating shaft is used for milling grains is called a Windmill. The earliest known windmill design dates back 3000 years to ancient Persia where they were used to grind grain. The earliest documented design of wind mill dates back to 200 B.C. in Persia. By the 13th century, grain grinding mills were popular in most of Europe. Tradition says that the knowledge spread into Northern Europe as a result of the Crusades (1095-1291 AD). In contrast with the vertical axis Persian design, European mills had horizontal axis. European millwrights became highly skilled craftsmen, developing the technology tremendously, and as Europeans set off colonizing the rest of the globe, windmills spread throughout the world. Figure 2A and 2B presents the earlier windmill and windpump systems.



Figure 2A: Earlier design of windmill



Figure 2B: Windpump

The Dutch were the pioneers in making these kinds of mills. They made many improvements in the design and invented several types of mills. The era of modern wind electric generators began close to 1900's. The first modern wind turbine, specifically designed for electricity generation, was constructed in Denmark in 1890. It supplied electricity to the rural areas. More systematic methods were adopted for the engineering design of turbines during this period. With low-solidity rotors and aerodynamically designed blades, these systems provide impressive field performance. By 1910, several hundreds of such machines were supplying electrical power to the villages in Denmark. By about 1925, wind electric generators became commercially available in the American market. Similarly, two and three bladed propeller turbines ranging from 0.2 to 3 kW in capacity were available for charging batteries. The first utility-scale wind electricity generation system was installed in Russia in 1931. A 100 kW turbine was installed on the Caspian Sea shore. Experimental wind plants were subsequently constructed in other countries like United States, Denmark, France, Germany and Great Britain. Some milestones in the history of wind machines are given in Unit I (Table 1). The Enercon E-126 turbine with a hub height of 135 m, rotor diameter of 126 m, total height of 198m and total weight of 6000 MT can generate 7.5 MW power per turbine today. Its first turbine was installed at Emden in Germany 2007. The world's largest wind farm, the Markbygden Wind Farm, with 1,101 turbines covering just 500 km² area to generate 4000 MW is under construction in northern Sweden and will contain approximately 150 Enercon E-126 7.5 MW wind turbines. Fig 3 represents the modern wind electric generator system. Fig 4 represents the development and growth of wind turbine from smaller rotor diameter to the large rotor diameter.



Figure 3: Modern wind electric generator

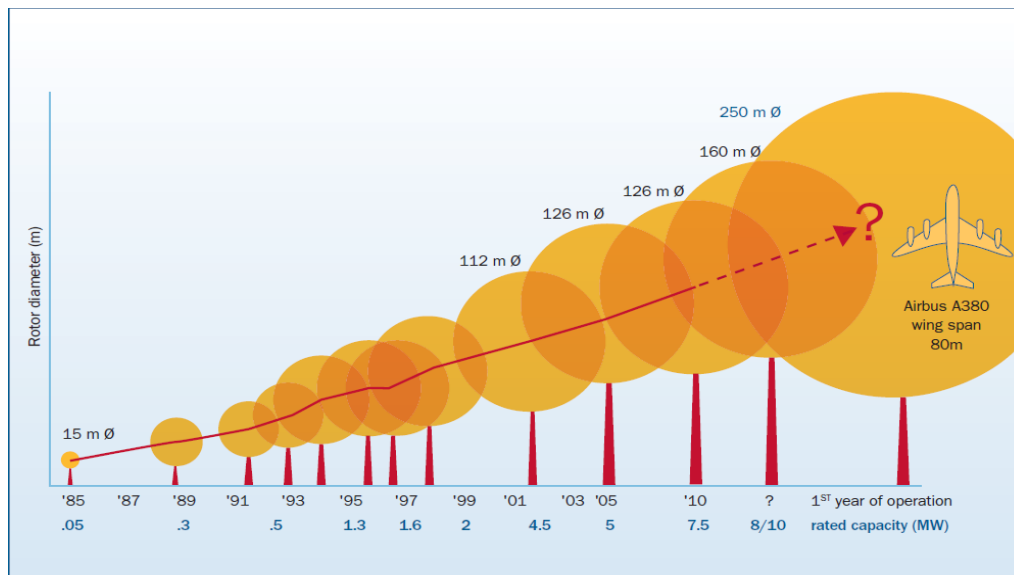

Figure 4: Development and growth of wind turbine

The modern wind turbine is a sophisticated piece of machinery with aerodynamically designed rotor and efficient power generation, transmission and regulation components. Size of these turbines ranges from a few Watts to several Mega Watts. Modern trend in the wind industry is to go for bigger units of several MW capacities, as the system scaling up can reduce the unit cost of wind generated electricity. Most of today's commercial machines are horizontal axis wind turbines (HAWT) with three bladed rotors. Though research and development activities on vertical axis wind turbines (VAWT) were intense during the end of the last century, VAWT could not evolve as a reliable alternative to the horizontal axis machines. The life span of modern wind turbines is now 20-25 years, which is comparable to many other conventional power generation technologies. The cost of wind power has continued to decline through technological development, increased production level, and the use of larger turbines.

The Wind energy conversion systems are classified into two categories depending on the applications. The mechanical application of WECS is called windmill or wind pump and for electricity generation, the system is called wind electric generator (WEG). Wind pumps are water-pumping systems, which appeared in America by the mid 1800's. Multi-bladed rotors, relatively smaller, mechanically coupled with reciprocating

piston pumps, were appropriate for water pumping application. The primary motive was to pump water from a few meters below the surface for agricultural uses. With metallic blades and better engineering design, they offered good field performance. The era of wind electric generators began close to 1900's. The first modern wind turbine, specifically designed for electricity generation, was constructed in Denmark in 1890. It supplied electricity to the rural areas. With low-solidity rotors and aerodynamically designed blades, these systems provided impressive field performance.

3.1 WIND ELECTRIC GENERATORS

Wind electric generators (WEG) have evolved into complex machines from ancient simple vertical axis wind turbines for water pumping or grain grinding. There are three major systems in a wind electric generator system.

- *Rotor system:* This includes blades that capture energy and a rotor hub that connects the blades to the shaft, along with pitch mechanism that assists in efficient capture of energy.
- *Nacelle:* This contains all the components that sit on top of the tower, except the rotor system. It includes main shaft, gearbox, generator, brake, bearings, nacelle frame, yaw mechanism, auxiliary crane, hydraulic system, and cooling system.
- *Tower and foundation.* These structural elements carry all the forces and moments to the ground.

Fig 5 represents how a turbine works and Fig 6 represents the various components of a HAWT and VAWT.

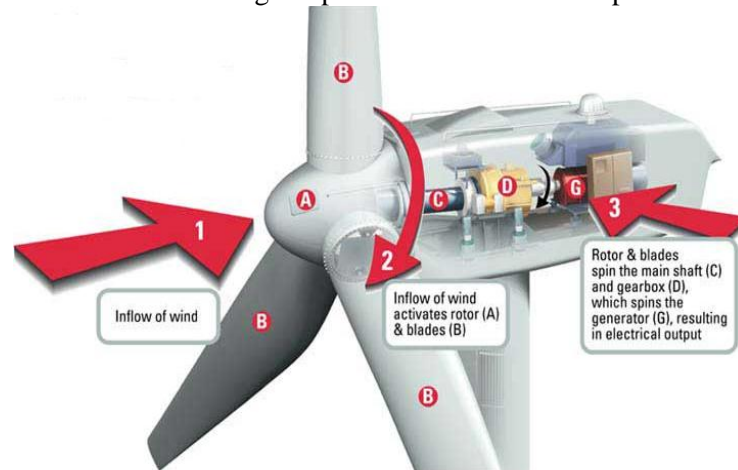

Figure 5: How does a wind turbine works

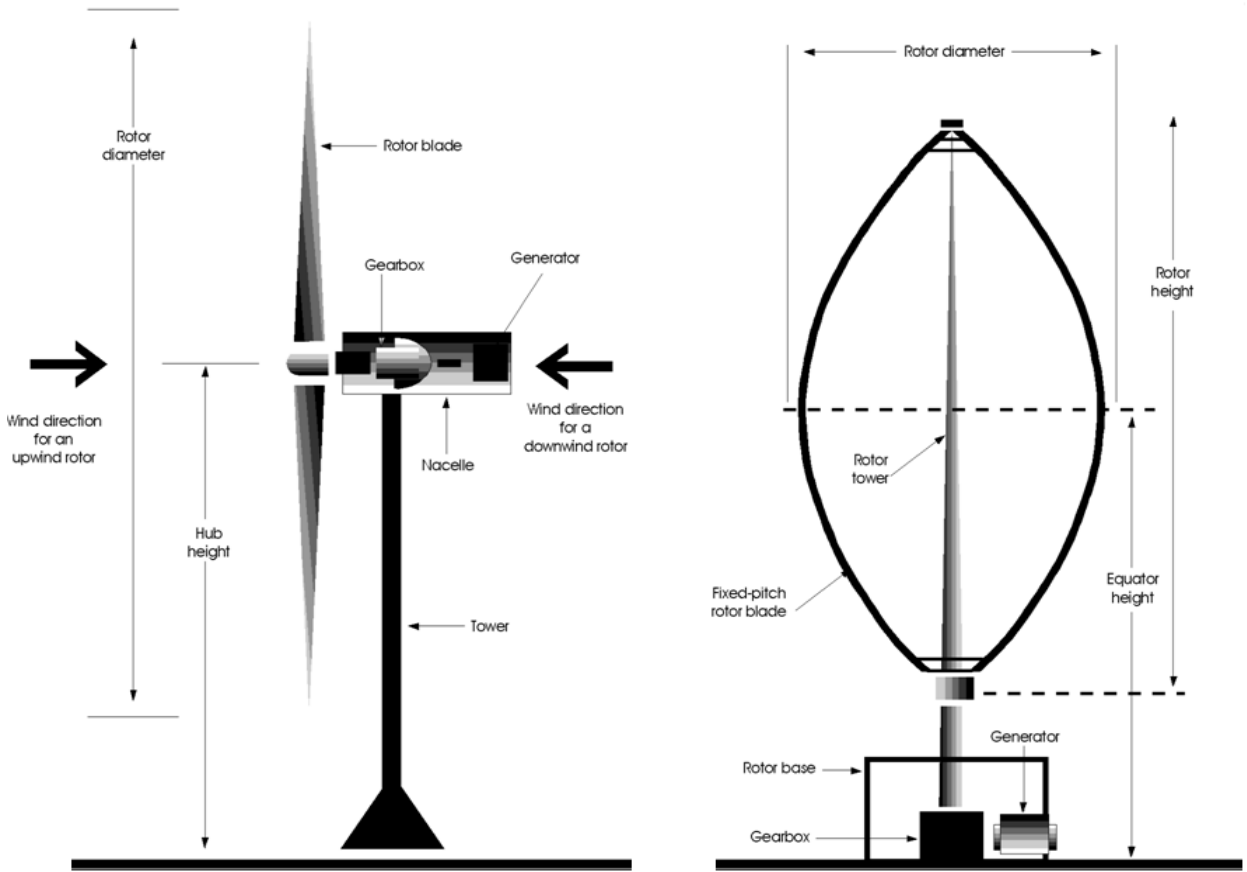

Figure 6: Different sections of HAWT and VAWT

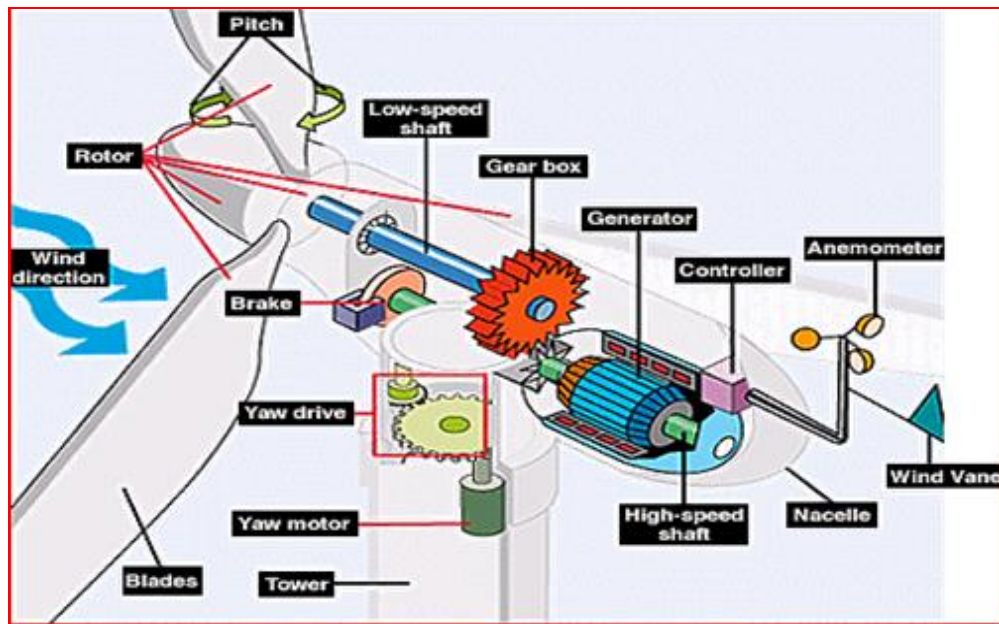

Figure 7: Components of a wind electric generator

Electricity generation is the most important application of wind energy today. Fig 7 represents the various components of a wind electric generator. The major components of a commercial wind turbine are:

- Tower
- Rotor
- High speed and low speed shafts
- Gear box
- Generator
- Sensors and yaw drive
- Power regulation and controlling units
- Safety systems

Figure 8A, 8B and 8C represents the basic parts of a small wind electric system, grid connected systems and hybrid systems respectively.

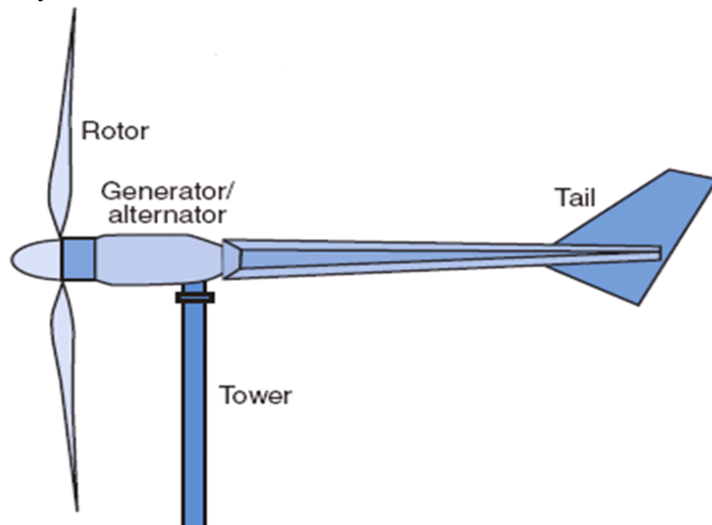

Figure 8A: Basic parts of a small wind electric system

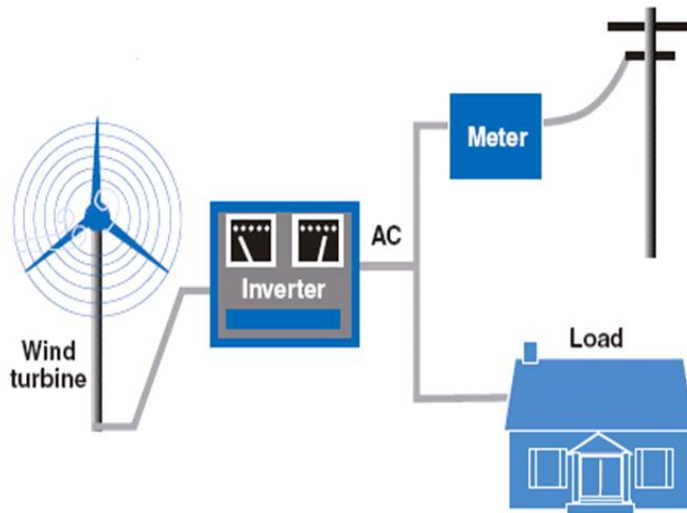

Figure 8B: Grid connected small wind electric generator

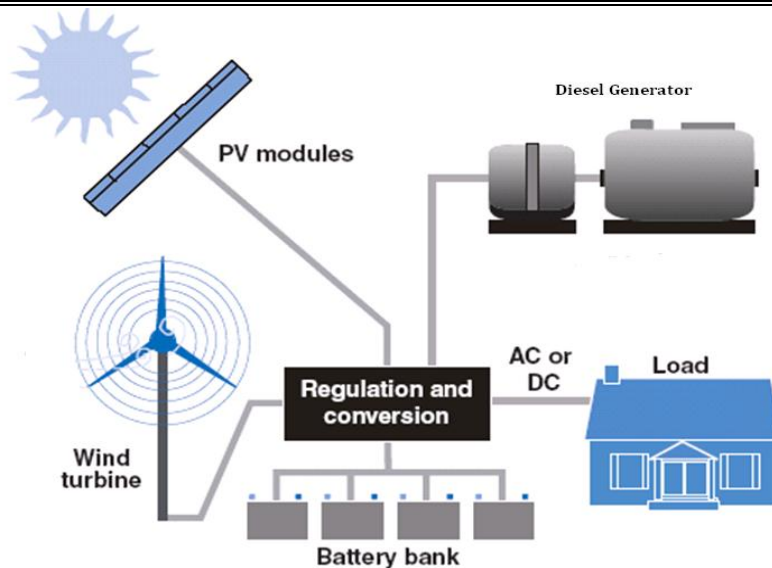

Figure 8C: Wind-Solar-Diesel generator based hybrid system

3.1.1 TOWER, ROTOR, GEARBOX, POWER REGULATION, SAFETY MECHANISM

3.1.1.1 TOWER

Tower supports the rotor and nacelle of a wind turbine at the desired height. Schematic views of the major types of towers used in modern turbines are shown in Fig 9. Towers for wind turbines may be either tubular steel towers, lattice towers, or concrete towers. Guyed tubular towers are only used for small wind turbines (battery chargers etc.) Most large wind turbines are coupled with tubular steel towers, which are manufactured in sections of 20-30 meters with flanges at either end, and bolted together on the site (Fig 10). The towers are conical (i.e. with their diameter increasing towards the base) in order to increase their strength and to save materials at the same time. Many small wind turbines are built with narrow pole towers supported by guy wires. The various types of tower and applications are as follows.

- | | |
|--|---------------------------|
| ○ Monopole (Nearly all large turbines) | Tubular Steel or Concrete |
| ○ Lattice (many Medium turbines) | 20 ft. sections |
| ○ Guyed | Lattice or monopole |

The lattice towers are fabricated with steel bars joined together to form the structure as shown in the figure. Lattice towers consume only half of the material that is required for a similar tubular tower. This makes them lighter and thus cheaper. Legs of these towers are spread widely as shown in the Fig 8. As the load is distributed over a wider area, these towers require comparatively lighter foundation, which will again contribute to the cost reduction. However, a few demerits of lattice towers are as follows:

- Poor aesthetics
- Increase in the rate of avian mortality as birds can easily perch on its horizontal bars
- Not maintenance friendly due to poor protection to workers against chilling weather
- Less secure for maintenance as the towers do not have any lockable doors

Due to these limitations, most of the recent installations are provided with tubular steel towers. These towers are fabricated by joining tubular sections of 10 to 20 m length. The complete tower can be assembled at the site within 2 or 3 days. The tubular tower, with its circular cross-section, can offer optimum bending resistance in all directions. These towers are aesthetically acceptable and pose less danger to the avian population.

For small systems, towers with guyed steel poles are being used. Usually, four cables equally spaced and inclined at 45°, support the tower. By partially supporting the turbine on guy wires, weight and thus the cost of the tower can be considerably reduced. As accesses to these towers are difficult, they are not much popular with large scale installations.

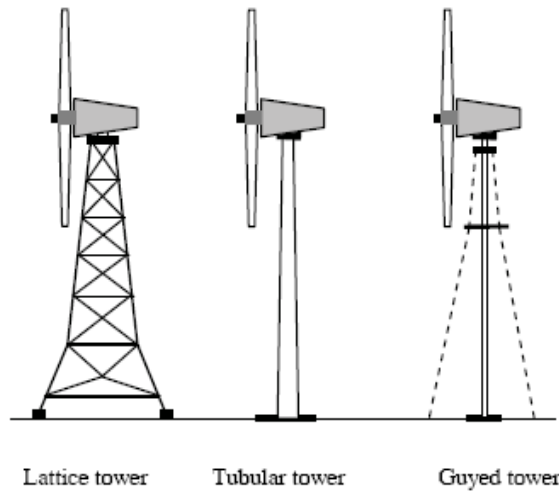

Figure 9: Different types of towers

Load acting on the tower increases with size of the turbine. Hence, higher sized systems demand higher tower dimensions (diameter and wall thickness). This imposes limitations while transportation of these towers. Hence, for high capacity systems, hybrid towers are also used. Wind velocity increases with height due to wind shear. Hence, the taller the tower, the higher will be the power available to the rotor.



Figure 10: Modern large WEG tower

3.1.1.2 ROTOR

Rotor is the most important and prominent part of a wind turbine. The rotor system captures wind energy, converts it into rotational kinetic energy and transforms it into mechanical shaft power. This is accomplished through blades that connect to a rotor hub that is connected to the main shaft. In large utility-scale turbines, the rotor hub has mechanisms to pitch the blade, that is, rotate along the longitudinal axis of the blade. Components of a wind turbine rotor are blades, hub, shaft, bearings and other internals.

Rotors may be single-bladed, two-bladed, three bladed or multi-bladed. However, single-bladed and two-bladed rotors are not popular due to visual acceptability problem and balancing and noise problems. Hence, almost all commercial designs have three bladed rotors. Some of the small wind turbines, used for battery charging, have more number of blades- four, five or even six-as they are designed to be self starting even at low wind speeds. Size of the rotor depends on the power rating of the turbine. Also, the turbine cost per rated power output decreases with the increase in turbine size. Hence, MW sized designs are getting popular in the industry.

Due to the aerodynamic profile of blades, as discussed in Unit 2, low pressure is created on the upper surface of a blade. This creates the lift, i.e. the force pulling upwards, the same principle that enables the plane to stay in the air. In case of the rotor blade of a wind mill, the lift is perpendicular to the direction of the wind. Choosing profiles for rotor blades involves a number of compromises including reliable pitch control and stall characteristics, and the profiles ability to perform well even if there is some dirt on the surface. In countries where rains occur during the whole year, the dirt gets cleaned by the rain water, but in relatively dry countries like India, dirt may become a problem. The basic principles behind the working of wings of airplanes and blades of wind turbines are quite common. However, since the wind turbines actually work in a very different environment with changing wind speeds and changing wind directions, there are special considerations that are not important in the design of airplane wings. Although turbine blades are, in principle, similar to airplane wings in terms of generating lift, there are significant design differences.

- Twist along the longitudinal axis of the blade, in order to achieve a constant angle of attack along the entire length of the blade, a twist is added to the blade.
- Turbine blades are thinner and longer because it yields enhanced performance in lower wind speed.
- Stall characteristics are different. Wind turbines continue to operate under stall conditions between rated and cut-out wind speed, whereas an airplane avoids stall conditions.

The cross section of a blade is shown in Fig 11. The components of a blade are:

- The core of the blade is made of balsa wood or foam; the core gives the blade its shape. This is also called the spar, which is like a long tubular beam along the length of the blade.
- Upwind and downwind aerodynamic shell made of fiberglass and epoxy resins. These two are glued at the leading and at the trailing edge. The shells are glued to the spar with an adhesive.
- Root of the blade is a metallic cylinder with bolts to connect the blade to the rotor hub.

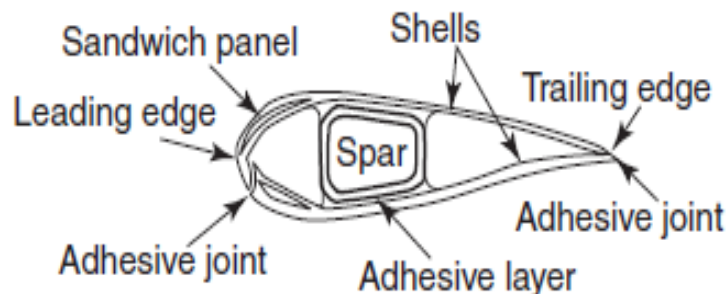

Figure 11: Cross-section of a blade

Size of the rotor depends on the power rating of the turbine. The turbine cost, in terms of \$ per rated kW, decreases with the increase in turbine size. Hence, MW sized designs are getting popular in the industry. NEG Micon has 4.5 MW turbines with blade length of 54 m. Some manufactures are planning even longer blades for their future projects. For example, the 61.5 m blade from the LM Glassfiber is being installed in a 5 MW turbine with 125 m rotor size. Fig 12 shows the blades in a production facility.

Blades are fabricated with a variety of materials ranging from wood to carbon composites. Use of wood and metal are limited to small scale units. Most of the large scale commercial systems are made with multi layered fiber glass blades. Attempts are being made to improve the blade behaviour by varying the matrix of

materials, reinforcement structures, ply terminations and manufacturing methods. With the increase in size, carbon-glass hybrid blades are being tried by some manufacturers. The merits of such blades, mainly due to introduction of carbon, are:

- Better fatigue characteristics under severe and repetitive loading
- High stiffness characteristic; reduces the possibility of blade bending in high winds and hence blades can be positioned close to the tower
- Improved edgewise fatigue resistance of blades; an advantage for bigger rotors
- Weight of the blades reduced by 20 per cent
- Lighter blade demands lighter supporting structures thus economizing the system
- Allows twist coupling the of blades which improves the turbine performance by better power regulation and quick response to wind gusts



Figure 12: Blades for wind electric generator

However, a demerit of using carbon-glass hybrid blades is that they are costlier. The blades of the rotor are attached to hub assembly. The hub assembly consists of hub, bolts, blade bearings, pitch system and internals. Hub is one of the critical components of the rotor requiring high strength qualities. They are subjected to repetitive loading due to the bending moments of the blade root. Due to the typical shape of the hub and high loads expected, it is usually cast in special iron alloys like the spherical graphite (SG) cast iron. The main shaft of the turbine passes through the main bearings. Roller bearings are commonly used for wind turbines. These bearings can tolerate slight errors in the alignment of the main shaft, thus eliminating the possibility of excessive edge loads. The bearings are lubricated with special quality grease which can withstand adverse climatic conditions. The main shaft is forged from hardened and tempered steel.

There are two common methods for the manufacturing of large blades: Epoxy prepregmolding and vacuum-assisted resin transfer molding (VARTM). In the epoxy prepregmolding, fiberglass impregnated with epoxy is laid out in layers and placed in a mold. The layers are pressed and then cured at elevated temperature. In the VARTM, fiberglass is laid in a pre-form and placed in a closed mold. In this mold, epoxy resin is sucked in using vacuum and then cured to form a blade. VARTM has resulted in a simpler process, although it is still time intensive. Application of epoxy resin on such a large structure without imperfections, like air pockets and without resin-rich pockets, is challenging. These imperfections cause stress concentrations leading to fatigue failure. One of the largest mass-produced blades is a 61.5-m blade for a 125-m rotor diameter offshore turbine with a weight of 18 tons. For this LM Glasfiber blade, about 30% reduction in weight was achieved with combination of carbon and glass fibers. Carbon fiber-reinforced plastics are lighter weight, possess about three times the stiffness of glass fiber-reinforced plastics, and possess significantly better fatigue properties.

3.1.1.3 GEARBOX

Gear box is an important component in the power trains of a wind turbine. Gear trains are to be introduced in the transmission line to manipulate the speed according to the requirement of the generator. For example, a gear train may typically raise the speed of the turbine rotor from 30 to 50 rpm to an optimum speed of 1000 to 1500 rpm for the generator. An ideal gear system should be designed to work smoothly and quietly-even under adverse climatic and loading conditions-throughout the life span of the turbine. Due to special constraints in the nacelle, the size is also a critical factor. Gears are designed on the basis of duration and distribution of loads on individual gear teeth.

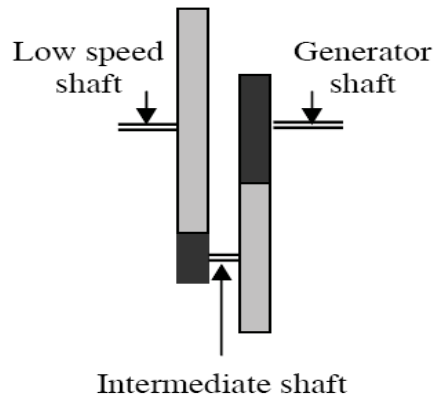

Figure 13: Gear arrangements of a small wind turbine



Figure 14: GE 1P 2.3 Gear box systems

GE 1P 2.3 (One-stage planetary with Two-stage parallel shaft)	
Power	1.8-2.3 MW @ 14-18 rpm input speed
Input torque	980-1250 kNm
Ratio	40:1 – 125:1
Output shaft type / location	Horizontal output shaft located at an 1100 mm centre distance
Approx weight	17,000 kg
Overall length	2200 mm

In smaller turbines, the desired speed ratio is achieved by introducing two or three staged gearing system as shown in Fig 13. For example, the rotational speed of the rotor is around 40 rpm, whereas the generator is designed to operate at 1000 rpm. Thus a gear ratio of 25 is required, which is accomplished in two stages as shown in the Fig 13. If higher gear ratios are required, a further set of gears on another intermediate shaft can be introduced in the system. However, the ratio between a set of gears are normally restricted to 1:6. Hence,

in bigger turbines, integrated gear boxes with a combination of planetary gears and normal gears are used. By introducing the planet gears, the gear box size can be considerably reduced. Moreover, planet gears can reliably transfer heavy loads. Bearings for different points of the gear box are selected based on the nature of loads to be transmitted. Fig 14 represents the commercial GE 1P 2.3 gear train system. The technical specification of this gear system is presented in the above box.

3.1.1.4 POWER REGULATION

Wind turbines are designed to produce electrical energy as much as possible. Wind turbines are therefore generally designed so that they yield maximum output at a particular wind speed. It does not pay much attention to design turbines that maximize their output at stronger winds, because such strong winds are rare. In case of stronger winds, it is necessary to waste part of the excess energy of the wind in order to avoid damaging the wind turbine. All wind turbines are therefore designed with some sort of power control.

Power generated by the turbine is regulated to its rated level between the rated and cut-out wind speeds. If not regulated, the power would have been increased with wind speed as indicated by the dotted lines as in the Fig 15. In that case, the system would require stronger transmission and bigger generator. But as the probability of high wind velocities is very low in the wind regime, it is not logical to over-design the system to accommodate the extra power available for a very short span of time. Moreover, the rotor may further speed up, finally reaching the run-away situation. It should also be noted that this increase in speed occurs in a short span of time, resulting in rapid acceleration. Hence, it is vital that the power of the turbine should be regulated at constant level, at velocities higher than the rated wind speed. Between the rated velocity and cut-out velocity, the system generates the same rated power, irrespective of the increase in wind velocity. At wind velocities higher than the cut-off limit, the turbine is not allowed to produce any power due to safety reasons. The common methods to regulate the power are as follows;

- Pitch control
- Stall control
- Active stall control
- Yaw control

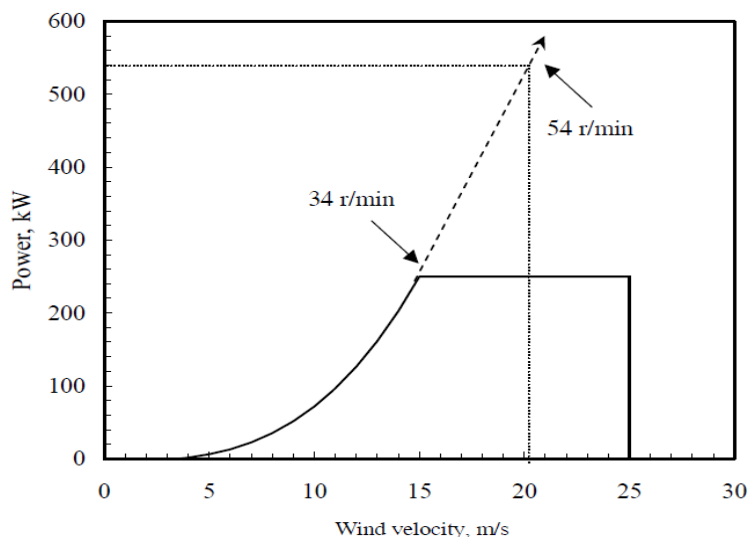

Figure 15: Power curve of a typical wind turbine

The power curve of a typical wind turbine presents in the Fig 15. This figure shows that the turbine starts generating power as the wind speeds crosses the cut-in velocity of 3.5 m/s and power slowly increases with the wind speed upto the rated wind velocity of 15 m/s, at which it generates its rated power of 250 kW. Between the rated velocity and cut-out velocity (25 m/s), the system generates the same rated power of 250

kW, irrespective of the increase in wind velocity. At wind velocities higher than the cut-off limit, the turbine is not allowed to produce any power due to safety reasons

Pitch control or regulation

We have seen in Unit 2, wind turbine blades has optimum lift coefficient at a particular angle of attack (C_l - α and C_l - C_d characteristics). The angle of attack of a given blade profile changes with the wind velocity and rotor speed. Fig 16 shows the pitch regulation mechanism.

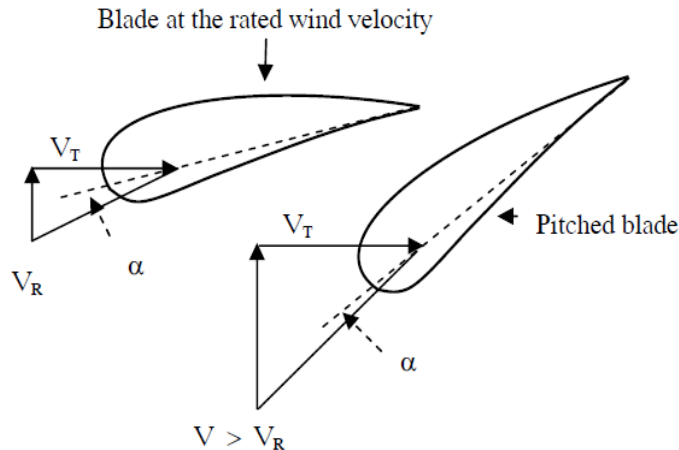

Figure 16: Principle of pitch control

As the rated wind speed (V_R) increases the angle of attack (α) decreases, or the lift coefficient term decreases. In pitch controlled wind turbine, the electronic sensors constantly monitors the variations in power produced by the system. The output power is checked several times in a second. According to the variations in power output, the pitch control mechanism is activated to adjust the blade pitch at the desired angle. The turbine is made to operate at its maximum efficiency between the cut-in and rated wind speeds by adjusting the blade pitch to the optimum angle of attack or near to the optimum lift coefficient. As the wind speed exceeds the rated wind speed, the control mechanism change the blade pitch resulting in changes in the angle of attack as shown in the Fig 16. We also know that any changes in the angle of attack from its optimum value would in turn reduce the efficiency of the rotor. Thus at the wind speed above than the rated wind speed, we are basically reducing the aerodynamic efficiency of the blades. In a pitch controlled turbine, the blades are to be turned about their longitudinal axis by the pitch control mechanism in tune with the variations in wind speed. The pitch control mechanisms are driven by a combination of hydraulic and mechanical devices.

Stall control

The basic principle of stall regulated turbines, the blade profiles are designed in such a way that when the wind velocity exceeds beyond the rated limit, the angle of attack increases (Fig 17). Or air flow on the upper side of the blade creates an irregular vortex, causing turbulence. This affects the lift force on the blades, finally leading to blade stall. Thus, the excess power generation at high wind is regulated.

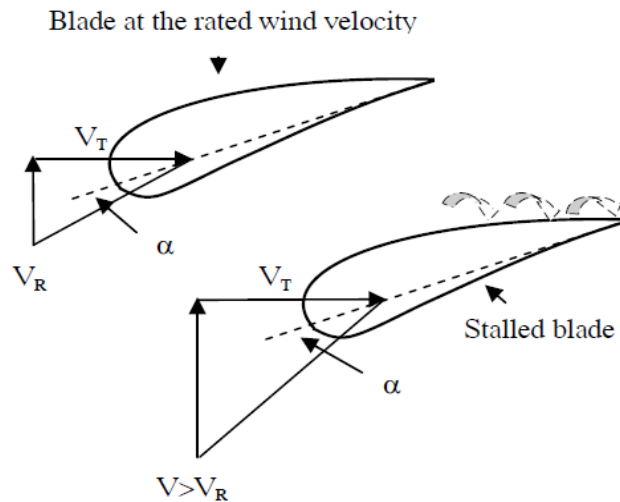

Figure 17: Principle of stall control

There are some basic differences between the pitch controlled turbines and stall control turbines. Pitch controlled turbine can capture the power more effectively in moderate winds as the blades can be set to its optimum angle of attack by pitching. However, moving components are to be introduced in the blade itself for adjusting its angle, which is a drawback of these systems. However, in case of stall controlled blades, no control system or pitching mechanism are required. Here, the blades are aerodynamically twisted along its longitudinal axis (changes of blade setting angle at certain length of the blade profile). Design and manufacturing of such blades demand sophistication.

Active stall control

Active stall control is the combinations of both pitch and stall regulation mechanism for regulating its power. In this method, the blades are pitched to attain its best performance in lower winds. However, once the wind exceeds the rated velocity, the blades are turned in the opposite direction to increase the angle of attack and thus forcing the blades into a stall region. The active stall allows more effective power control and the turbine can be run nearly at its rated capacity at high winds.

Yaw control

Yaw control refers to the rotation of the whole rotor system partly away from the wind direction at higher wind speeds. The rotor axis is pushed to an angle to the incoming wind direction at high winds and the power generation comes down at high wind speeds. At the cut-out limit the Yaw axis position would be nearly perpendicular to the wind vector, thus ceasing the power generation. When the rotor is partially yawed, it experiences cyclic stresses. Due to this reason, yaw control is employed only for small wind turbines.

3.1.1.5 SAFETY MECHANISM

Wind electric generator without safety usually will have a very short life. It is also important to note that at recent history, at very high wind speeds, wind machines have been blown away into pieces. This is due to the safety systems were not at all present or badly designed. Hence, the safety mechanism function is needed to bring the turbine to a safe condition in the event of a serious or potentially serious problem. Each safety systems must perform two actions.

- *Limit the axial thrust forces on the rotor:* at high wind speed, the bending moment on the blades becomes too high and eventually they will break.
- *Limit the rotational speed of the rotor:* at high rotational speed the following phenomena can happen.

- High centrifugal force, resulting in high tensile forces on the blades. Finally one of the blades may come out from the systems, leaving the systems unbalanced.
- A combination of high rotor speed and sudden directional changes of the rotor head gives rise to high gyroscopic moments, i.e. high bending moments in the blades and the rotor shaft.
- High tip-speed ratio can induce dangerous aero-elastic behaviour of the system.
- In case of wind pump, the high pump frequency lead to a sharp increase of the shock forces.

There are two types of brakes are commonly used with wind turbines. They are aerodynamic brakes and mechanical brakes. In order to ensure the safety, one brake function as the primary brake and the other as a backup option this comes in to action if the primary system fails. Aerodynamic brakes are the primary system in most of the wind turbines. In pitch and active stall controlled systems, the entire blade is turned 90° along its longitudinal axis, there by hindering the driving lift force. Thus the rotor would stop after making a few more rotations. In contrast, it is the tip of the blade which is moved in stall controlled turbine. Position of the blade tip, relative to the blade, can be changed using a shaft and bearing assembly fixed inside the main body of the blades. During normal operation, the tip is held in position with the blade using hydraulic force. When the blades are to be stopped, the hydraulic force that keeps the tip in line with the blade is cut-off, there by allowing the blade tip to move outwards. Driving unit of the blade shaft is then activated which turns the tip through 90°. This brings the blades to the braking position. Although the blades are not completely stopped by tip braking, the rotor can be brought to a freewheeling speed, which is much lower than its normal operating speed. Once the dangerous situation is over, the blades are brought back to the working position by the hydraulic system. Field experience shows that the aerodynamic braking is quite effective in protecting the turbines.

In addition to the aerodynamic braking, a mechanical brake is also provided with the turbine as a back up system. These brakes are applied to bring the rotor to ‘full stop’ position in stall controlled turbines. They are also useful to lock the rotor during the turbine maintenance. Mechanical brakes are friction devices, consisting of brake disc, brake calliper, brake blocks, spring loaded activator and hydraulic control. The brake disc is fixed to the high speed shaft coming from the gear box. Under normal operation, the brake disc and blocks are held apart by hydraulic pressure. When the system is to be braked due to safety reasons, this pressure is released and the brake spring presses the block against the disc. This will bring the system to halt. Being frictional devices operating under extreme loading, the brake blocks are made with special alloys which can tolerate high stress and temperature.

The safety systems can act either on the rotor or as a whole or on each of the blades. The different designs are summarized for this purpose and listed below.

Rotor	<hr/> Turning the rotor sideways <hr/> <ul style="list-style-type: none"> ● Inclined hinged vane (<i>eccentric rotor or auxiliary vane balances vane</i>) ● Ecliptic control (<i>eccentric rotor balances spring-loaded vane</i>) ● Pressure plant (<i>plates dis-locks the vane</i>) <hr/> Turning the rotor upwards <hr/> Brake flaps, separate from the blades (<i>brake action and spoiling rotor flow</i>) <hr/>
Blades	<hr/> Pitch control (<i>changing setting of angle of blades, positive or negative</i>) <ul style="list-style-type: none"> ● Centrifugal weights ● Axial forces on the blade ● Externally operated (hydraulic or servo) <hr/> Stall of blades (<i>for constant speed turbines with fixed pitch blades</i>) <hr/>

Brake flaps at the tip of the blades

- Flap axis parallel to blade axis
- Flap axis perpendicular to the blade axis

Spoilers

(movable ridges that spoil part of the blade's performance)

3.1.2 GENERATOR: INDUCTION AND SYNCHRONOUS GENERATOR

Generator is one of the most important components of a wind energy conversion system. Since wind velocity is varying in nature, the generator of a wind turbine has to work under fluctuating power levels, in tune with the variations in wind velocity. Different types of generators are being used with wind machines. Small wind turbines are equipped with DC generators (permanent magnet type) of a few Watts to kilo Watts in capacity. Bigger systems use single or three phase AC generators. As large-scale wind generation plants are generally integrated with the grid, three phase AC generators is the right option for turbines installed at such plants. These generators can either be induction (asynchronous) generators or synchronous generators.

3.1.2.1 INDUCTION GENERATOR

Most of the wind turbines are equipped with induction generators, also called Squirrel Cage Induction Generators (SCIG). The cross sectional view of an induction generator is shown in Fig 18. Most of the wind turbines are equipped with induction generators. They are simple and rugged in construction and offer impressive efficiency under varying operating conditions. As the rotor speed of these generators is not synchronized, they are also called asynchronous generators. Induction machines can operate both in motor and generator modes. The mechanism of an induction machine is as follows:

- The three stator phase windings are connected to a three-phase AC-voltage source (the grid). This results in AC-currents flowing through each of the stator windings. When the stator windings are symmetrically distributed along the stator circumference, and when the three-phase voltage source is perfectly balanced, the currents in each of the stator windings work together to produce one rotary magnetic field.
- This magnetic field crosses the rotor squirrel cage radially. Each set of neighbouring rotor bars forms, together with the segments of the end rings between them, a closed electrical circuit. Those circuits are linked with the radial magnetic field, which, seen from the point of view of the rotor circuits, varies at a frequency equal to the rotational speed of the magnetic field minus the rotor mechanical speed. A voltage is induced among each of the rotor circuits, according to Faraday's Law. This causes electrical currents to flow through the rotor bars and the ring segments.
- The interaction of the rotor bar currents and the already present magnetic field generate a tangential force on the rotor, according to Lorentz Force Law, generating a torque in the rotation direction (motor) or against it (generator).

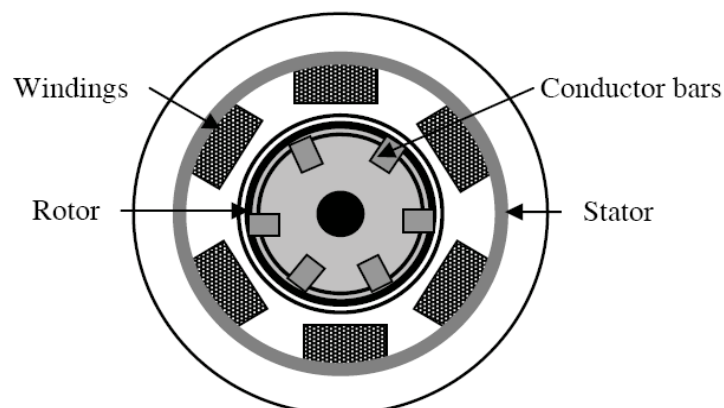

Figure 18: Cross-sectional view of an induction machine

An induction machine can operate as a motor or a generator, depending whether mechanical torque is required or supplied. The mechanical rotor speed is strongly linked to the rotational speed of the magnetic field, which, at its turn, has a fixed relation with the grid frequency. The rotor always tends to chase the rotating flux to reduce the relative velocity. However, it never succeeds in attaining the same speed due to frictional losses (if it succeeds, there will not be any relative speed between the two and hence no induced electro-magnetic force or current). Hence, the rotor always rotates at a speed slightly lower than the synchronous speed. The difference between the synchronous speed (N_S) and the rotor speed (N_R) is termed as the slip of the motor. Thus, the slip (S) is given by

$$S = \frac{N_S - N_R}{N_S}$$

Where, N_S is the synchronous speed which again depends on the grid frequency and N_R is the rotor speed. Again, the synchronous speed is that speed of an electrical machine which is dependent upon the frequency of supply current (f), which is fixed, and the number of poles in the machine (P). It is given by,

$$N_S = \frac{120 \times f}{P}$$

Thus, an induction motor with 4 poles, connected to a grid of 50 Hz current, will have a synchronous speed of 1500 rpm. Now considering with 1 per cent slip, the speed of the rotor will be 1485 rpm. It is obvious from the relation that the speed of the motor can be manipulated by changing the number of poles. In the above example, if we use a six pole motor, then the synchronous speed can be reduced to 1000 rpm.

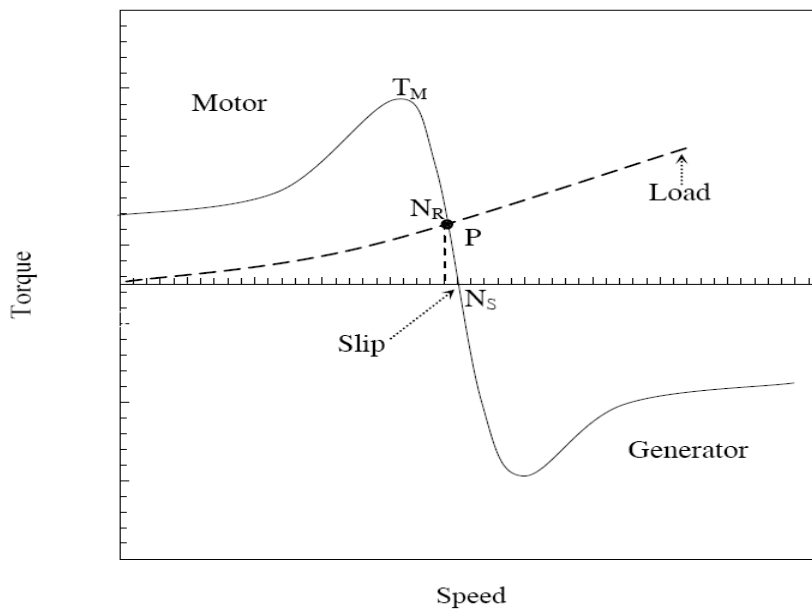

Figure 19: Characteristics of a typical induction machine

A typical torque-speed curve of the machine is shown in Fig.19. The torque-speed curves of the motor and the load are intersecting at a point P. This is the steady state condition for the given load and the system will settle to work at this point. N_R is the speed corresponding to P, which is less than the synchronous speed N_S . The difference between N_S and N_R is the slip. At this phase of operation, the machine acts as a motor. When this machine is coupled to a grid integrated wind turbine, initially it draws current from the grid as in case of a motor. As the speed picks up, the rotation of the wind turbine causes the system to exceed the synchronous limit N_S . Thus, rotor moves faster than the rotating magnetic field. The torque is then negative as seen from the figure. Thus, current flows in the opposite direction, that is from the system to the grid and the machine functions as a generator. As the working speed exceeds the synchronous speed in the generator phase, the slip is negative. Generally the slip is in the range of 1-3 per cent. External excitation is essential for an

induction generator before it is put to work. Grid integrated systems, can draw the required current from the grid. However, stand alone systems would require external devices like capacitors or batteries to provide the necessary excitation current to the generator. Such kinds of generators are;

- are simple and robust in construction
- easy and relatively cheap mass production of the generator
- efficient under varying operating conditions.
- require minimum maintenance and care
- posses over speed capability making them suitable for wind turbine application.

3.1.2.2 SYNCHRONOUS GENERATOR

In a synchronous generator, the rotor and magnetic field rotates at the same speed (synchronous speed). It consists of a rotor and a three-phase stator similar to an induction generator. The stator and rotor have the same number of poles. The generator shown in the Fig 20 has two poles. The stator has coils wound around them, which are accommodated in slots as shown in the figure. The stator windings are displaced circumferentially at 120° interval. Most of the synchronous generators coupled with wind turbines are employed with electromagnets. The magnetization is achieved by feeding direct current to the rotor field windings. Brush type or brushless exciters can be used to magnetize the rotor. The magnetization current may be drawn from the grid also; however it must be converted to DC before using it for magnetization. This excitation establishes strong north-south magnetic characteristics in the rotor poles. As the wind turbine turns the rotor, the magnetic field linking the stator coil varies sinusoidal with time, in proportion with the rotor speed. The rate of change of flux induces a sinusoidal voltage in the coils. At 120° separation the coils generate a balanced three-phase supply which is fed to the grid.

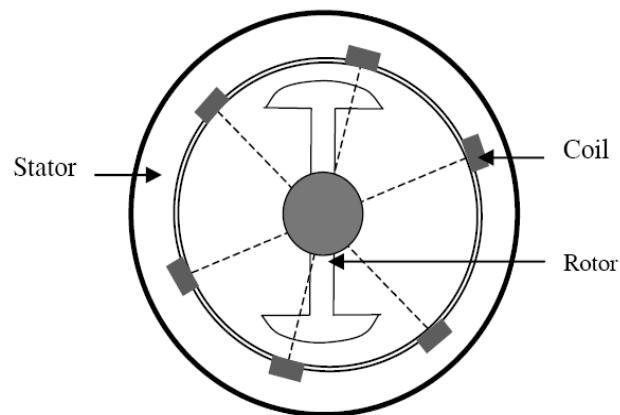

Figure 20: Principle of synchronous generator

A generator with 6 poles would run at 1000 rpm whereas with 24 poles, the speed can be reduced to 250 rpm and so on. Generators with six poles are commonly used with wind turbines. The lower the speed, the lesser will be the gearing requirement. However, more poles in the generator imply increased bulkiness and expensive.

3.1.2.3 FIXED AND VARIABLE SPEED OPERATIONS

A wind turbine can be designed to run at fixed or variable speeds. In fixed speed turbines, the rotor is coupled with an induction generator via speed increasing gears. Fig 21 shows a fixed speed wind turbine systems. As we know, induction generators require excitation power from the grid. This may result in undesirable voltage variations, especially in weaker networks. To avoid this problem, capacitors are provided in the circuit as shown in the Fig 21. With this configuration, the wind turbine will run at constant (or nearly constant) speed and feed the grid with power in a predetermined frequency (50 Hz or 60 Hz).

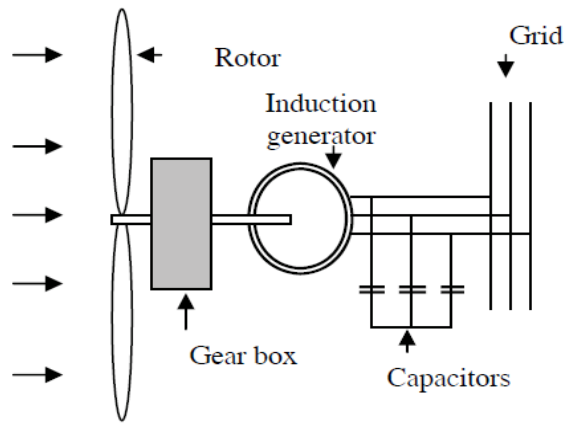

Figure 21: Fixed speed wind turbine

Wind turbines which operate in variable speeds are equipped with either synchronous generators or a doubly fed induction generators. In systems with synchronous generator, the operating speed changes randomly with fluctuations in the wind velocity and hence the output voltage and frequency would also vary. This output cannot be directly fed to the grid due to its poor power quality. Thus the wind turbine is totally decoupled from the grid in the variable speed option. The power is fed to the grid after conditioning through a suitable interface (Fig. 22). Thus, the AC generated by the synchronous generator is first rectified into direct current and then inverted back to AC at standard grid frequencies (50 Hz or 60 Hz), before feeding it to the grid.

In variable speed turbines with doubly fed induction generators, the stator winding is directly connected to the grid. However, the rotor winding is fed through a converter which can vary the electrical frequency as desired by the grid. Thus the electrical frequency is differentiated from the mechanical frequency, which allows the variable speed operation possible. Typical configuration of such a system is shown in Fig. 23.

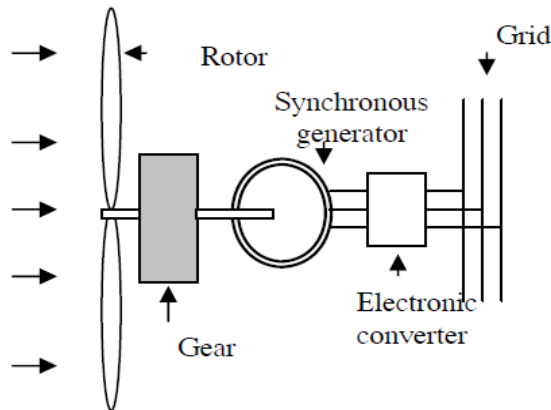

Figure 22: Variable speed wind turbine with synchronous generator

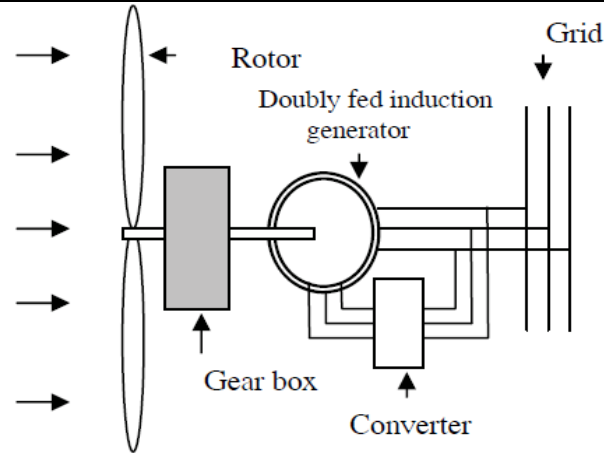

Figure 23: Variable speed wind turbine with doubly fed induction generator

3.1.3 GRID INTEGRATION

Grid Integration of wind energy means connecting or feeding the wind power output to an already existing electricity grid for supply to various utilities on large scales. An electrical grid is an interconnected network for delivering electricity from generating stations to consumers. The grid can aggregate the various wind farm outputs installed at a variety of geographical locations having different weather patterns. The grid integration of wind energy in recent years became important as the share of wind generated electricity in the grid is increasing day by day. In some of the country this is a very serious issue as the grid penetration has reached to a sufficiently high level. In some specific areas of Denmark, it is as high as 80 per cent. Even in India, states like Tamilnadu, where grid penetration is 27% of total installed capacity. Grid penetration definitely needs careful integration of wind energy to the electrical network. The quality of the electrical network to which wind energy is fed is one of the important factors to be considered in the grid integration. The output frequency has to be maintained very closely to 50 or 60 Hz, depending on the local norms. The grid needs to be strong enough to withstand the characteristics of wind generated electricity. Instability in the grid can cause the wind farm to shut down. This becomes more critical if the penetration rate is high.

3.2 WIND PUMPS

One of the classical applications of wind energy is water pumping. Water pumping is one of the main applications of wind energy in the past and despite the spread of electric pumps, more than a million wind pumps are still in regular use. The most widely used types of pump today is constructed of a steel, multi-bladed, high solidity ratio, fan-like rotor which drives a reciprocating pump linkage usually via reduction gearing which in turn connects directly with a piston pump. Fig 24 presents a general water pumping systems based on wind mill. The design of wind turbines for water pumping is relatively simple compared to the wind electricity generating turbines. The mechanical power at rotor shaft is used directly to drive a pumping device. Turbines with high starting torque are suitable for pumping and this required high solidity ratio operating at low tip speed ratio of 2 or less. Also the most prevailing wind turbines for water pumping are of horizontal axis type and typically have rotors with 12-24 blades, diameters of 2-5m and hub height of 10-30 m. The rotor blades are usually made from cured sheet metal and need not to be complex airfoil section. The important components of wind pump are as follows;

- *Rotor*: This can vary widely in both size and design. Diameters range from less than 2 m up to 7m. The number of blades can vary from about 6 to 24.
- *Tail*: It keeps the rotor pointing towards wind like a weather vane. The whole assembly at the top of the rotor rotates along the wind direction and allows the rotor to face wind.
- *Transmission system*: It turns the rotation of the rotor into reciprocating motion (up and down) in the pump rod. Gearbox also used sometimes in this system. Otherwise, for direct drive systems, the pump rod moves up and down once for each turn of the rotor.

- *Pump rod*: It transmits the motion from the transmission at the top of the tower to the pump at the bottom of the well. The motion of the pump rod is reciprocating (up and down) and the distance it travels called the stroke.
- *Pump*: It is normally submerged below water level on the downward stroke, the cylinder filled water and on upward stroke, the water is lifted by the piston.
- *Tower*: It is normally galvanised steel with three to four legs. Its height varies from 5m to 20 m. The bases of the legs are fixed and often blotted to concrete foundation.

Mechanical wind pumps can further be categorized as systems with positive displacement and roto-dynamic pumps. Various types of pumps like the screw pump, piston pump, centrifugal pump, regenerative pump and compressor pump are being used in mechanical wind pumping option. Roto-dynamic pumps-mainly the centrifugal- are used with the electrical system.

Cost effective innovative wind pump for irrigation

Windmill has great advantages for irrigation purposes throughout the world. This is mainly due to the non-availability of electricity or due to the high the cost of oil, which is difficult to afford for small scale farmer. In Assam, two innovators designed a low cost wind mill consisted of a tower like structure, made of bamboo posts, turbine blades, with a tail and a crank mechanism for converting the rotation of the blades into reciprocating motion (Fig 25). In the modified model, the aluminium blades are replaced by light weighted fibre-reinforced plastics and the bamboo poles by steel for greater effectiveness. A tilting mechanism is also included to protect the wind mill from high wind speed. The water discharge capacity of this model is approximately 1500 to 1600 litres per hour at a wind speed of 8 to 10 km per hour and water height of 50 feet to 60 feet. This model is being sold between Rs. 6000 to Rs. 40,000 and already 30 to 35 units of the models have been sold out.



Figure 24: Wind pump for water pumping

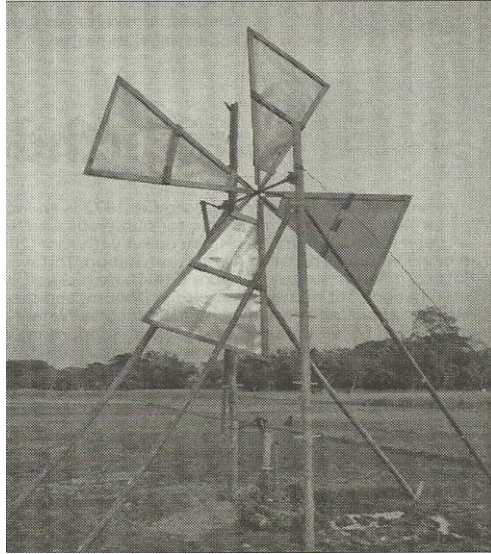

Figure 25: cost effective innovative windpump

3.2.1 WIND POWERED PISTON PUMP, LIMITATIONS AND PERFORMANCE ANALYSIS

The need to lift water is as old as mankind and consequently there exists a large variety of water lifting devices. Here, our discussion shall limit to wind powered reciprocating piston pumps. A reciprocating pump basically consists of a piston, two valves, suction and a delivery pipe (Fig 26). In the traditional piston pump, the lower valve is called the foot valve. The operating principle of a reciprocating pump is simple: if the piston moves downwards the upper valves open, the foot valves closes, i.e. the flow is zero and the piston pump moves freely through the water column. As soon as the piston moves upward, the upper valve will close, the foot valves opens and water is being lifted (above the piston) and sucked (below the piston, if the pump is above the water level) until the piston moves downwards again. The result is a pulsating sinusoidal water flow, like an AC current after passing a rectifier. It is a mechanical pump system and consists of a high solidity multi-vane wind rotor, drive shaft, crank, connecting rod and a reciprocating pump. Rotary motion of the windmill rotor is translated to reciprocating motion of the connecting rod by the crank. The connecting rod operates the pump's piston up and down through the cylinder during its strokes. Two check valves, both opening upwards, are fitted on the piston and the bottom of the pump. These valves allow the flow only in upward direction.

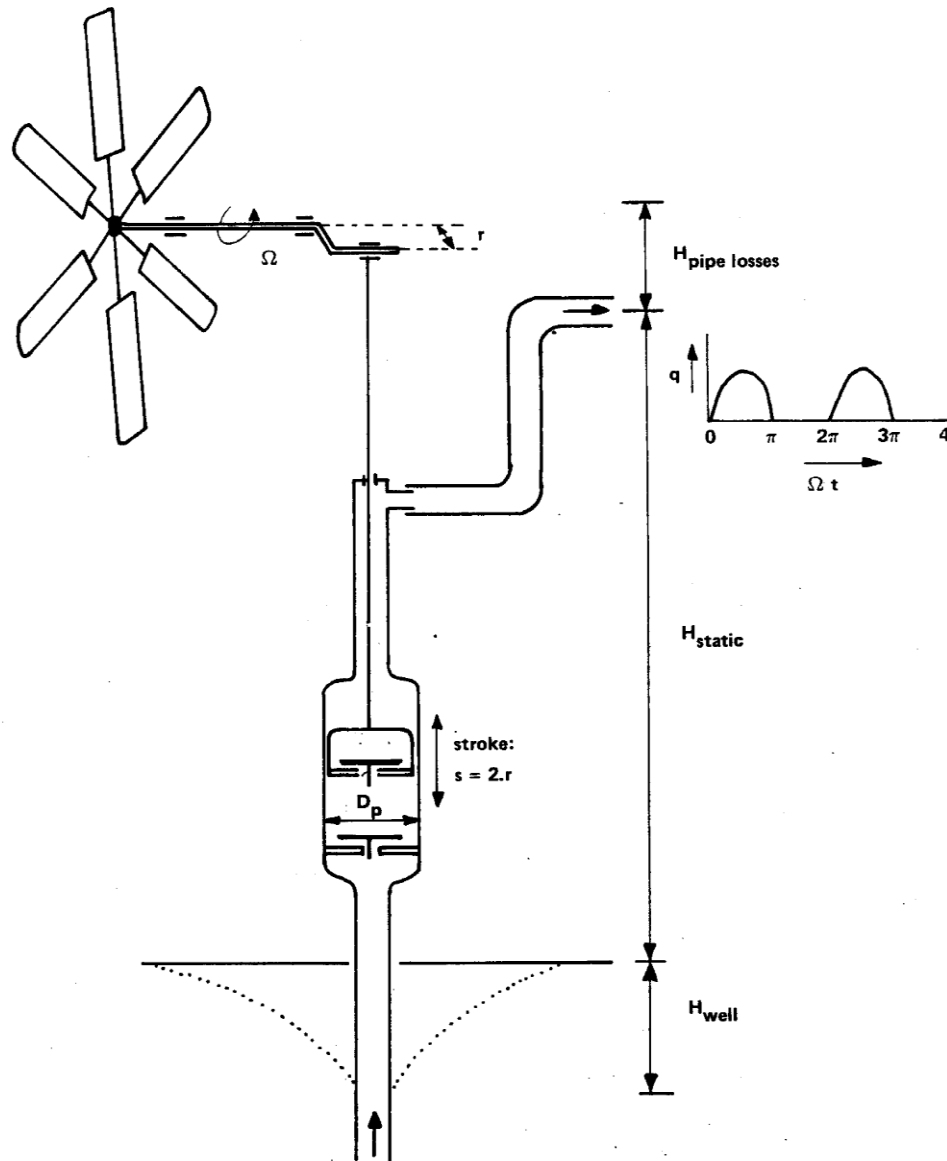

Figure 26: Schematic diagram of a reciprocating piston pump connected with a wind rotor

3.2.1.1 COUPLING OF PUMPS AND WIND ROTOR

If a pump is coupled to a wind rotor at a given wind speed V , the rotor will turn at a speed such that the mechanical power of the rotor is equal to the mechanical power exerted by the pump. This working point is very important for design purpose. From Fig 27, it can be found by the intersection of the rotor and the pump curve. The actual flow of water lifted by the rotor-pump combination at the given wind speed is found by drawing the Phyrdr curve (Fig 27), noting that the power at the rotational speed of the working point and divided by $\rho_w g H$. However, to obtain the hydraulic output as a function of wind speed, a series of rotor power curves must be drawn.

It is interesting to note that the resulting output power curve follows a linear function of the wind speed. The overall efficiency varies strongly with the wind speed. Now, we can easily define the wind speed at which the overall efficiency reaches a maximum as the designed wind speed (V_d) of the system. In other way, it is the wind speed at which the maximum power coefficient (C_p) reaches its maximum value $C_{p\ max}$. This design wind speed can also be calculate by assuming that at each wind speed, the net power supplied by the

rotor-pump combination must be equal to the hydraulic power to lift the water. Or, we can write in mathematical form

Net rotor-pump power = hydraulic power.

$$\eta_{mech} \times P_{mech} = P_{hydr}$$

$$\eta_{mech} \times \frac{1}{2} \rho V^3 \pi R^2 \times C_p = Q \rho_w g H$$

Now at the designed wind speed (V_d);

$$\eta_{mech} \times \frac{1}{2} \rho V_d^3 \pi R^2 \times C_p = Q_d \rho_w g H$$

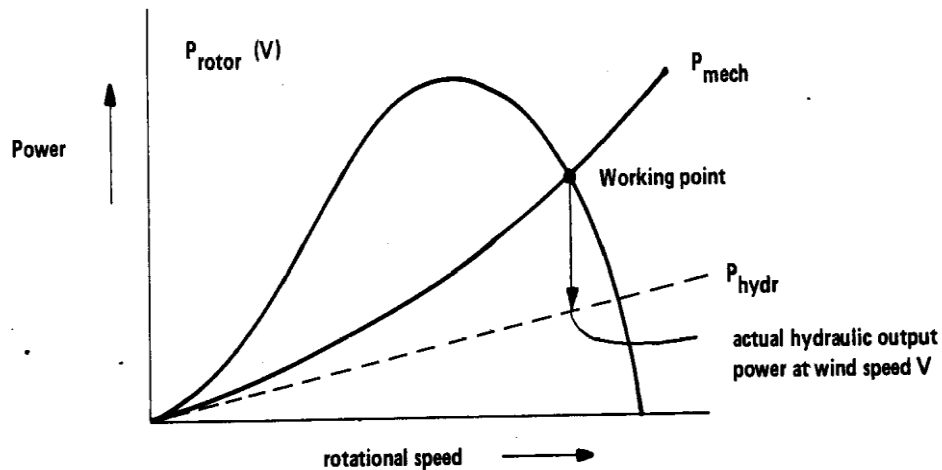

Figure 27: Working point of a rotor-pump combination at a given wind speed

Now the flow Q is equal to the ideal flow, which can be determined by the stroke volume and the speed, multiplied by the volumetric efficiency of the pump.

$$Q = \eta_{vol} \times s \times \frac{\pi}{4} D_p^2 \times \frac{\Omega}{2\pi}$$

Or,

$$Q = \eta_{vol} \times s \times \frac{\pi}{4} D_p^2 \times \frac{\lambda V}{2\pi R}$$

Now substituting this flow rate equation in the earlier equation for $V=V_d$, we can easily obtain the designed wind speed.

$$\eta_{mech} \times \frac{1}{2} \rho V_d^3 \pi R^2 \times C_p = \left[\eta_{vol} \times s \times \frac{\pi}{4} D_p^2 \times \frac{\lambda_d V_d}{2\pi R} \right] \times \rho_w g H$$

Or,

$$V_d = \sqrt{\frac{\eta_{vol} \times s \times D_p^2 \times \lambda_d \times \rho_w g H}{4 C_{p \max} \times \eta_{mech} \times \rho \pi R^3}}$$

Now, it can be easily observed that the designed wind speed can be easily changed by changing the stroke length, or by installing one other pump. Even, a change in water lifting head will also change the designed wind speed.

Example 2

The diameter of a pump is 0.14 m, stroke length 0.080 m and the operating head is 11.4 m. The diameter of the wind rotor is 4m, and the maximum power coefficient is 0.38 at the designed tip speed ratio of 2. The volumetric efficiency of the pump and the mechanical efficiency are 98 percent and 85 percent respectively. Calculate the designed wind speed.

Now, the designed wind speed can be calculated by using the following relation

$$V_d = \sqrt{\frac{\eta_{vol} \times s \times D_p^2 \times \lambda_d \times \rho_w \times gH}{4C_{p\ max} \times \eta_{mech} \times \rho \pi R^3}}$$

Where

$$\eta_{vol} = 0.98, s = 0.08, D_p = 0.14, \lambda_d = 2, \rho_w = 1000, g = 9.81, H = 11.4; C_{p\ max} = 0.38, \eta_{mech} = 0.85, \rho = 1.2 \text{ and } R = 2$$

Hence,

$$V_d = \sqrt{\frac{0.98 \times 0.080 \times 0.14^2 \times 2 \times 1000 \times 9.8 \times 11.4}{4 \times 0.38 \times 0.85 \times 1.2 \times 3.14 \times 2^3}} = 2.99 \frac{m}{s}$$

3.2.1.2 PERFORMANCE ANALYSIS

The volume of water discharged during one delivery stroke (V_s) is given by the product of inner area of the cylinder and the height through which the water column is displaced during a stroke. Thus, if 'd' is the inner diameter of the pump cylinder and 's' is the stroke length (distance between the extreme lower and upper positions of the piston) then, theoretically the volume of water pumped per discharge stroke is given by

$$V_s = \frac{\pi}{4} d^2 s$$

Where d is the inner diameter of pump cylinder, s is the stroke length of piston. From the Fig xx, we can observed that $S=2r$, where r is the crank length.

Now, as the the pump delivers one discharge per revolution of the wind rotor, the discharge is given by

$$Q = \eta_V \frac{\pi}{2} d^2 r N$$

Where, η_V is the volumetric efficiency of the pump, N is the rotational speed of the rotor. The volumetric efficiency of the pump is typically higher than 90 percent. The power requirement (PH) of the pump for the discharge (Q) can be estimated by

$$P_H = \frac{\rho_w g Q h}{\eta_P}$$

Where ρ_w is the density of water, g is the gravitational constant, h is the total head against which the pump delivers water and η_P is the pump efficiency. Density of water, under standard ambient conditions, can be taken as 1000 kg/m³. The pumping head includes the suction head, delivery head as well as the frictional head. Similarly, the pump efficiency takes care of various efficiencies involved in converting the mechanical shaft power to hydraulic power.

Example 3

The discharge of a wind powered piston pump at 5 m/s is 75 l/min for a pumping head of 20 m. Find out the rotor size of the wind pump. Power coefficient of the rotor at this velocity is 0.22 and the pump efficiency is 80 per cent.

The hydraulic power required by the pump for delivering 75 l/min (0.00125 m³/s) against 20 m head is

$$P_H = \frac{\rho_w g Q h}{\eta_P}$$

$$P_H = \frac{1000 \times 9.81 \times 0.00125 \times 20}{0.8} = 306.6 \text{ W}$$

Now, to develop this 306.6 W at wind speed of 5 m/s, the rotor diameter will be

$$P_H = \frac{1}{2} \rho \pi R^2 V^3 C_P$$

$$R = \sqrt{\frac{2P_H}{\rho \pi V^3 C_P}} = \sqrt{\frac{2 \times 306.6}{1.12 \times 3.14 \times 5^3 \times 0.22}} = 2.52 \text{ m}$$

Hence, the rotor diameter will be 5 m.

3.2.1.3 LIMITATIONS OF WIND DRIVEN PISTON PUMPS

Wind driven piston pumps are simple and cost effective. However, the field performances of these units are not encouraging. The major limitations of these kinds of systems are:

- Hysteresis behaviour of the system due to its high starting torque demand
- Mismatch between the characteristics of the rotor and the pump
- Dynamic loading of the pump's lift rod

QUESTIONS

1. Write down a short note on the History of wind energy conversion system development.
2. What are the cut-in, rated and cut-out wind speeds with reference to power performance characteristics of a wind turbine? How it is chosen for optimal performance of wind turbine?
3. Explain the offshore wind farms, their feasibility, prospects and technological challenges.
4. Explain the various issues related to grid integration of wind electric generator.
5. A constant speed pitch regulated wind machine with 60 m diameter, 14.32 rpm and 1.0 MW rated generator capacity is installed at a site with annual values of Weibull parameters c and k given by 7.2 m/s and 1.8 respectively. It has cut-in wind speed of 4 m/s and cut-out wind speed 27m/s. It has 3 blades and the mechanical and electrical efficiencies for all wind speeds are given as 0.95 and 0.96 respectively. Its coefficient of performance (CP) as function of tip speed ratio (λ) is given by

$$C_P = 0.089 + 0.0123\lambda^2 - 0.00091\lambda^3$$
 Find the electrical power developed by the machine as a function of speed from cut-in wind speed to cut-out wind speed in the step of 1m/s. Take air density as 1.1.65 kg/m³.
 - (a) Identify the speed at which regulation should start.
 - (b) Find the annual energy output at this site
 - (c) Find for how many hours the machine will run in a year
 - (d) What is the capacity factor of the machine?
 - (e) What is the probability of the wind speed exceeding the cut-out wind speed at this site?
 - (f) Find the most frequent wind speed.

SUGGESTED READING REFERENCES

11. Jain P. Wind Energy Engineering. McGraw-Hill, New York, 2011
12. Jha AR. Wind Turbine Technology. CRC Press, Taylor & Francis Group, 2011

13. Johnson GL. Wind Energy Systems (Electronic Edition), Prentice Hall Inc, 2006
14. Mathew S. Wind Energy: Fundamentals, Resource Analysis and Economics, Springer, 2006.
15. Burton T. Sharpe D. Jenkins N. Bossanyi E. Wind Energy Handbook. John Wiley, 2001

DRE 104: WIND AND HYDRO ENERGY

UNIT-4: WIND ENERGY SYSTEMS: ENVIRONMENT AND ECONOMICS

UNIT STRUCTURE

INTRODUCTION

4.1 ENVIRONMENTAL BENEFITS AND PROBLEMS OF WIND ENERGY

4.1.1 ENVIRONMENTAL BENEFITS OF WIND ENERGY

4.1.2 PROBLEMS ASSOCIATED WITH WIND ENERGY

4.1.2.1 RISK TO AVIAN SPECIES (BIRDS)

4.1.2.2 NOISE

4.1.2.3 VISUAL IMPACTS

4.2 ECONOMICS OF WIND ENERGY

4.2.1 FACTORS INFLUENCING THE COST OF ENERGY GENERATION

4.2.1.1 SITE SPECIFIC PARAMETERS

4.2.1.2 MACHINE PARAMETERS

4.2.2 LIFE CYCLE COST ANALYSIS

Objectives

The most significant environmental advantage of wind energy is that it does not emit any green house gases to the environment unlike the conventional coal based power plants. Wind energy is one of the most cost-effective renewable energy resources. The power available from wind mainly depends on the wind speed of a particular site. So wind resource assessment is pre-requisite before any kind of system installation. The objective of this unit is to introduce the learners about the environmental and economic issues related to wind energy systems.

INTRODUCTION

Fossil fuel based power plants, contributing more than seventy per cent to our energy needs today, dominate the global energy scenario. These plants pollute the atmosphere with harmful gasses and particulates. As per the estimates of the International Energy Agency (IEA), 23683 Mt of CO₂ has been released to the atmosphere by the power sector during 2001. Emission of CO₂ due to power generation has registered an increase of 65 per cent in during the past three decades. With the increase in energy demand, level of environmental pollution caused by the power sector is expected to increase further in the coming years. Environmental pollution and the emission of CO₂ (carbon dioxide) from the use of fossil fuels constitute a threat to health, the environment and sustainable economic growth. Other major pollutants from conventional electricity, which are avoided through wind power, include SO₂, NO_x and particulate matter.

The most serious threat comes from accelerating climate change, whose effects are already being seen around the world in rising temperatures, melting ice caps and volatile weather patterns. Climate change is a direct result of the greenhouse effect – the build-up of greenhouse gases in the atmosphere above the earth. Carbon dioxide emissions from power plants, industry and the transport sector are the largest contributor. The Intergovernmental Panel on Climate Change (IPCC) has predicted that human-induced greenhouse gas emissions will lead to a substantial increase in global mean temperatures, which will rise between 1.4 and 5.8 degrees over the course of this century.

As most renewable energy sources emit neither greenhouse gases nor other pollutants such as SO₂ (sulphur dioxide) or NO_x (nitrogen oxide), they will form the basis of any long-term sustainable energy supply system. The large-scale use of renewable energy sources is essential if the necessary reductions in CO₂ and other emissions from electricity generation are to be met and if sustainable development and sustainable growth are to be achieved. In contrast to conventional power plant, wind energy does not pollute the air or water with harmful gases and materials. Nor does it generate hazardous wastes, which cannot be safely disposed as in case of nuclear power plants. Being renewable sources of energy, extracting energy from wind does not pose the threat of over exploiting the limited natural resources like coal, oil or natural gas. Hence wind is considered as one of the cleanest sources of energy available today.

Wind energy has significant environmental benefits, including no emissions into the environment during energy production, no thermal pollution of river or lake water, and no exclusive land use. Since no fuels are used, the energy production causes no emissions at all. This is unlike coal, diesel, and natural gas-fired power plants that are large contributors to greenhouse gases and to a variety of other pollutants into the atmosphere and land. Mining of coal and extraction and processing of crude and natural gas also cause pollution. In coal and nuclear power plants, a large amount of water is required either to produce steam or to cool the fuel rods. Any other fuel that releases energy during combustion has to release part of the heat to the environment causing thermal pollution.

Wind turbines cause virtually no emissions during their operation and very little during their manufacture, installation, maintenance and removal. Because the fuel is free, wind generated electricity should be used as often as possible in the electricity system to replace intermediate power loads, from coal and gas. If we can exploit even a small fraction of this abundant and environment friendly source of energy, today's power related emissions can be reduced to a much acceptable level. For example, if 10 per cent of the wind potential in US is effectively exploited, the total carbon dioxide emission from the country can be reduced by 33 per cent, which is equivalent to a reduction of 4 per cent in the global level. Across Europe in 2003, wind power on average was responsible for the annual reduction of 27 million tonnes of CO₂. By 2020, taking European Wind Energy Association (EWEA) projections that 180GW of wind energy would be generating 425 TWh of energy per annum, and this wind power will provide

- annual saving of 215 million tonnes CO₂.
- annual saving of 261,000 tonnes SO₂.
- annual savings of 333,000 tonnes NO_x.

As in case of any human activities, wind energy generation is also not totally free from environmental consequences. The major environmental problem with wind energy is avian mortality due to collision with turbines and related structures. Noise emission and the visual impacts on landscapes are the other issues to be tackled. However, it should be noted that these environmental impacts are not global (as in case of atmospheric emissions and global warming) and thus, this can be monitored and resolved at local level.

4.1 ENVIRONMENTAL BENEFITS AND PROBLEMS OF WIND ENERGY

4.1.1 ENVIRONMENTAL BENEFITS OF WIND ENERGY

The most significant environmental advantage of wind energy is that it does not load the atmosphere with toxic chemicals. In contrast, the conventional power plants operating on fossil fuels release gases like sulphur dioxide, carbon dioxide and oxides of nitrogen during the energy conversion process. Similarly, particulates and toxic heavy metals which affect the environment adversely are also being generated during this process. Fig 1 represents the specific emission rates from a typical power plant based on pulverized coal. Emission due to the fossil fuel based generation depends on the type and quality of fuel used and the technology of power conversion.

Three quarter of the global emission of CO₂ is due to the burning of fossil fuels. Accumulation of carbon dioxide in the atmosphere causes the green house effect and thus the global warming. The green house gases permits the sun's rays to enter the atmosphere but traps the reflected infrared radiation. This causes the atmosphere to get warmer. The global warming causes the weather pattern to change, the sea level to rise and the land use configuration to alter.

Nuclear energy-which is often projected as the energy source for the future by some corners-is also not free from environmental risks. All the processes involved in the nuclear energy technology are prone to environmental hazards. Radioactive isotopes, which are generated right from the mining of uranium, its processing and enrichment and plutonium production, may pollute the ground water, land and plants. These may be active for several thousands of years, posing threat to the entire ecosystem. Further, a safe and reliable way to dispose the hazardous waste produced at different stages of the nuclear energy generation is also not very easy. Another problem with this technology is the high risk of accidents.

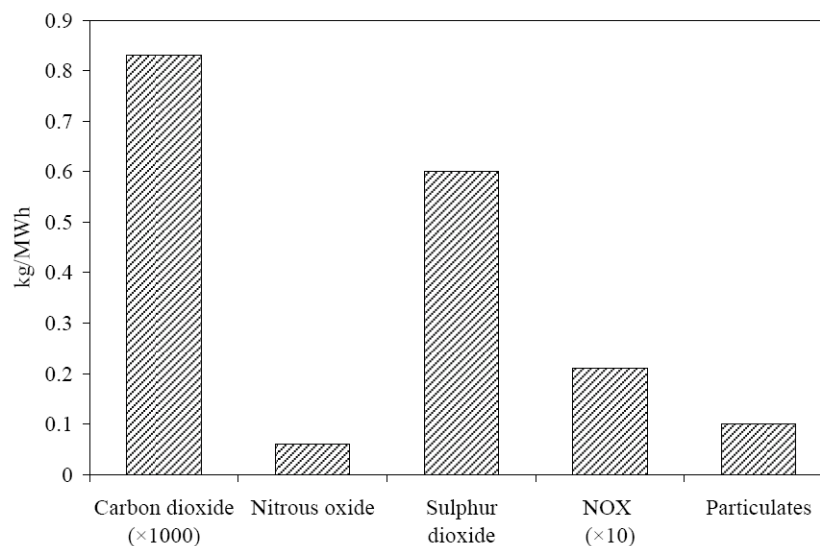

Figure 1: Atmospheric emissions from a coal based power plants

Here comes the significance of the clean sources like wind in meeting our energy demand in a sustainable and environment-friendly way. Wind energy systems neither generate polluting gasses, nor does it emit to the environment with harmful particulates. The technology also does not pose problems of radiation and waste management. Table 1 provides the typical values of annual reduction in atmospheric emissions due to a 5MW wind farm.

Table 1 Annual reduction in atmospheric emissions due to a 5MW wind turbine

Pollutant	Reduction (kg)
Carbon dioxide	8932178
Nitrous oxide	645.7
Sulphur dioxide	6456
NOx	22599.5
Particulates	1076.2

4.1.2 PROBLEMS ASSOCIATED WITH WIND ENERGY

Human intervention of any nature has its own environmental consequences. Wind energy is not an exception. Although wind is one of the cleanest sources of energy and does not pollute the environment with harmful gases during its energy conversion process. However, wind energy systems pose some environmental problems. Environmental issues are one of the prime concerns before setting up a wind installation farm at a location. Apart from being economically viable, it should be environmentally acceptable. Hence, it is most important to abide by environmental legislations for the successful planning and development of a wind farm. It is necessary to conduct a local survey and consult the local planning authority in order to determine the environmental acceptability of the project. It should be noted that these environmental impacts are not global (as in case of atmospheric emissions and global warming) and thus can be monitored and resolved at local level. The local community's opinion should be taken while discussing the project's acceptability to the residents. It should be ensured that the project comply with the statutory requirements prevailing in the region. If a site does not meet the requirements in the above aspects, it may be dropped from the list. The major environmental consequences of wind energy conversion are

- risk to avian species
- noise
- visual impacts

4.1.2.1 RISK TO AVIAN SPECIES (BIRDS)

Birds and bats may collide with wind turbines, as they do with any structures on their route. It is by the late 1980's that the impact of wind turbines on avian population has become an issue of concern. Studies conducted at the large wind resource area at the Altamont pass, east of San Francisco, California, indicated high levels of bird mortality due to collision with wind turbines. Hence the potential effect of any proposed wind farm development on the birds of concern should be systematically studied. All the bird groups of special concern, including the breeding, migrating and wintering species, including the functional behaviour of the species in the region should be monitored and analysed. The presence of a wind farm may affect bird life in various ways, such as, (i) collision, (ii) disturbance, and (iii) habitat loss. Horizontal axis turbines mounted on horizontal lattice towers are more susceptible to bird collision. Further, these types of tower structures with flat crossbars provide ideal platform for perching birds. The avian risk at a given site can be reduced to some extent by the optimum layout of the wind farm and configuration of individual turbines. Clear spaces should be available for the birds to pass through especially in the areas of migration to minimize the risk of bird collision.

4.1.2.2 NOISE

Noise is a form of pollution generated by turbines. However, the impact of sound is limited to a few hundred meters from the base of a turbine. Noise is generated in a turbine from two primary sources:

- Aerodynamic interactions between the blades and wind. This is the persistent "whoosh" sound as the blades slice the wind. This is the dominant noise from a turbine
- Mechanical noise from different parts of the turbine

The mechanical noise is contributed by the relative motion of components like gear box, generator, yaw motors, cooling fans, hydraulic pumps and other accessories. The aerodynamic noise arises when the blades of the wind turbine interact with the air stream. A number of complex flow phenomena occur around the blade, each contributing to the noise generated from the system. Modern wind turbine designs have improved to the point where mechanical noise is insignificant, so the issue is now aerodynamic noise from the turning blades. At a distance of 300 meters from a 1 MW wind turbine, the expected sound level would be 45 decibels (dBA). The 'subjective' impression at this level is deemed 'quiet'. The noise from turbines is usually masked by other ambient sounds such as the movement of trees when the wind picks up, or near an industrial or urban area. Fig 2 represents the noise level for various cases.

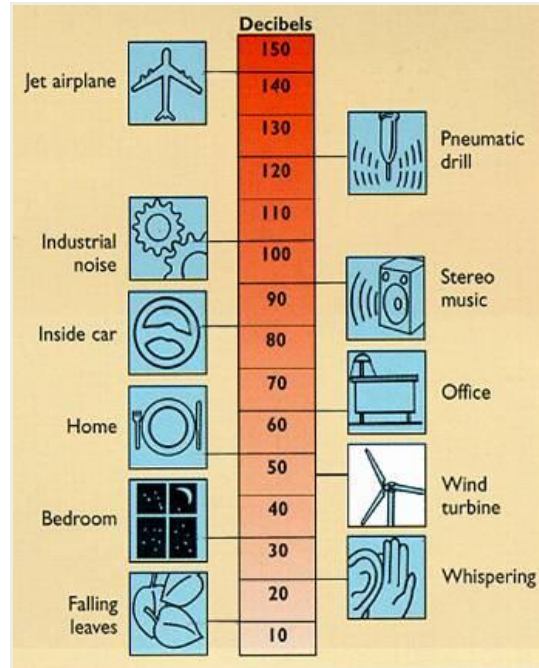

Figure 2: Noise level for various cases

4.1.2.3 VISUAL IMPACTS

In comparison to other energy developments, such as nuclear, coal and gas power stations or open cast coal mining, wind farms have relatively little visual impact. Nevertheless, most countries with a wind power industry have established rules which exclude certain areas from development, such as national parks or habitat zones. Others have identified priority areas where wind power is specifically encouraged. Wind farm developers recognize that visual impact can be a concern for neighbouring communities. Considerable effort is therefore committed to the planning stages in order to reduce the impact and gain their consent. Visual impact is the most difficult to quantify and is often the primary reason for opposing a wind project. Although there is widespread support for wind energy projects, in general, the support drops when the project is close to one's community because of the not-in-my-backyard syndrome. Most projects do not adequately address visual impact issues and even when visual assessments are done, subjective approaches are adopted to assess visual impact. Although a wind energy project can spread across a large total land area, it does not occupy all that space. Farming or leisure activities can still continue around the turbines. The European Wind Energy Association has estimated that the number of wind farms required to contribute 20% of Europe's electricity supply would take up only a few hundred square kilometres.

4.2 ECONOMICS OF WIND ENERGY

We have discussed so far the technological aspects of wind energy. The criteria for selection of a good wind site, technical issues related to performance analysis, capacity factor for a particular machine at a particular site. However, the key issue is the economic aspect of energy generation from wind energy systems. Thus, along with issues like "how efficient is the system?" and "how much energy will it produce?", the question "at what cost can we generate energy?" Or what is the lowest possible cost per kWh generation. At present, with the technology and institutional support, wind energy is economically competitive with other conventional sources like coal and natural gas. It is cheaper than all other renewable like solar, hydro, biomass and geothermal.

Economic issues of wind energy systems are multidimensional. There are several factors that affect the unit cost of electricity produced by a wind turbine. These may vary from country to country and region to region. Economic merit of a wind powered generation plant heavily depends on the local conditions. For a wind turbine, the fuel is free, but the capital investment is high. While assessing the initial investment for the

project, apart from the cost of the wind turbine, investment for other essential requirements like land, transmission lines, power conditioning systems etc. should also be accounted. The main parameters governing wind power economics include:

- investment costs, (capital cost and auxiliary costs for foundation and grid connection)
- operation and maintenance costs
- electricity production/average wind speed
- turbine lifetime

The most important parameters are turbine electricity production and investment costs. As electricity production depends to a large extent on wind conditions, choosing the right installation site is critical to achieving economic viability. The capital costs of wind energy projects are dominated by the cost of the wind turbine itself (ex-works). Table 2 shows the typical cost structure for a 2 MW turbine erected in Europe.

Table 2: Cost structure of a typical 2 MW wind turbine installed in Europe (2006)

Items	Investement (euro 1000/MW)	Share (%)
Turbine (ex-works)	928	75.6
Foundations	80	6.5
Electric installation	18	1.5
Grid connection	109	8.9
Control systems	4	0.3
Consultancy	15	1.2
Land	48	3.9
Financial costs	15	1.2
Road	11	0.9
Total	1227	100
<i>Source : Riso DTU</i>		

The turbine's share of the total cost is, on average, around 76 per cent, while grid connection accounts for around 9 per cent and foundations for around 7 per cent. The cost of acquiring a turbine site (on land) varies significantly between projects, so the figures in Table 2 are only to be taken as examples. Other cost components, such as control systems and land, account for only a minor share of total costs. Fig 3 represents the cost of each components of the turbine of a 5MW wind turbine. In recent years, three major trends have dominated the development of grid-connected wind turbines:

- Turbines have become larger and taller – the average size of turbines sold on the market has increased substantially
- The efficiency of turbine production has increased steadily
- In general, the investment costs per kW have decreased

Operation and maintenance (O&M) costs constitute a sizeable share of the total annual costs of a wind turbine. For a new turbine, O&M costs may easily make up 20-25 per cent of the total levelised cost per kWh produced over the lifetime of the turbine. If the turbine is fairly new, the share may only be 10-15 per cent, but this may increase to at least 20–35 per cent by the end of the turbine's lifetime. As a result, O&M costs are attracting greater attention, as manufacturers attempt to lower these costs significantly by developing new turbine designs that require fewer regular service visits and less turbine downtime. O&M costs are related to a limited number of cost components, including:

- insurance
- regular maintenance
- repair
- spare parts and

- administration

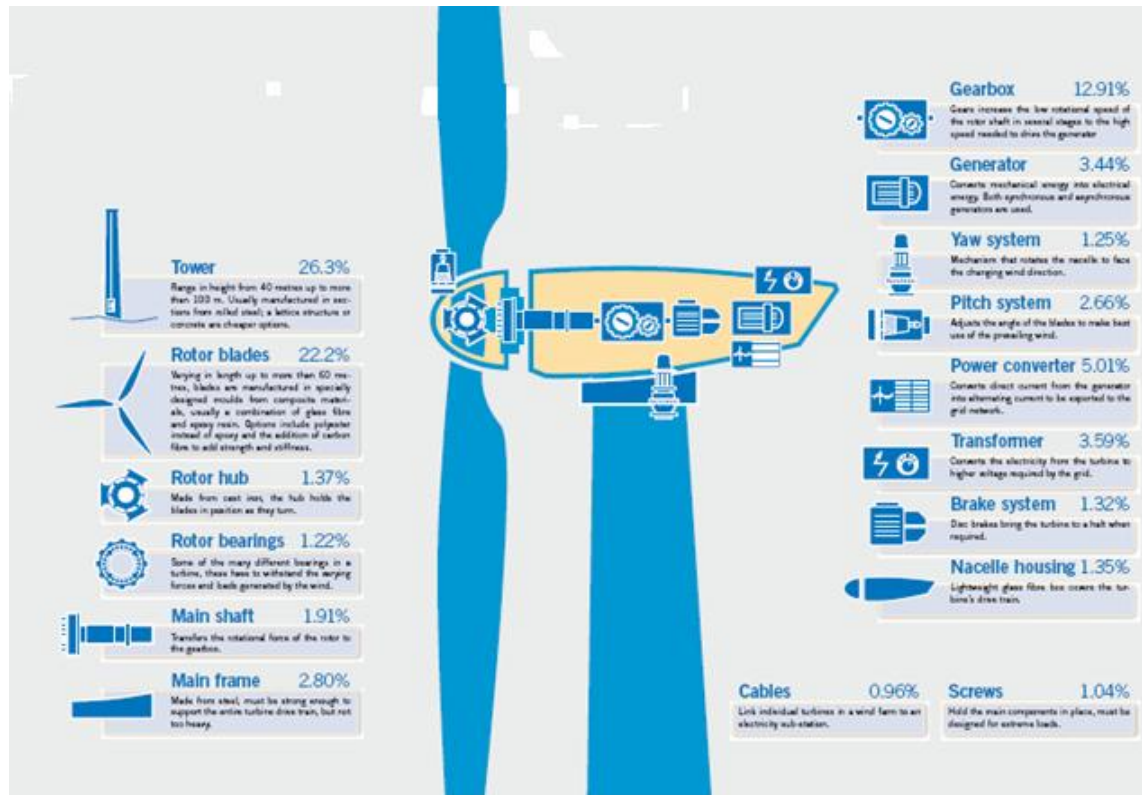

Source: Wind Directions, January/February 2007

Figure 3: Main components of a wind turbine and their share of the overall turbine cost for a 5 MW wind turbine

The total cost per kWh produced (unit cost) is calculated by discounting and levelling investment and O&M costs over the lifetime of the turbine and then dividing them by the annual electricity production. The unit cost of generation is thus calculated as an average cost over the turbine's lifetime. In reality, actual costs will be lower than the calculated average at the beginning of the turbine's life, due to low O&M costs, and will increase over the period of turbine use. The turbine's power production is the single most important factor for the cost per unit of power generated. The profitability of a turbine depends largely on whether it is sited at a good wind location. The costs range from approximately 7–10 c€/kWh at sites with low average wind speeds to approximately 5–6.5 c€/kWh at windy coastal sites, with an average of approximately 7c€/kWh at a wind site with average wind speeds. Approximately 75–80 per cent of total power production costs for a wind turbine are related to capital costs - that is, the costs of the turbine, foundations, electrical equipment and grid connection. Thus a wind turbine is capital-intensive compared with conventional fossil fuel-fired technologies, such as natural gas power plants, where as much as 40–60 per cent of total costs are related to fuel and O&M costs. For this reason, the costs of capital (discount or interest rate) are an important factor for the cost of wind-generated power.

4.2.1 FACTORS INFLUENCING THE COST OF ENERGY GENERATION

4.2.1.1 SITE SPECIFIC PARAMETERS

Energy available in wind spectra is proportional to the cube of the wind speed. This implies that when the speed of the wind at a location doubles, the energy increases by eight times. Hence, the availability of good wind speed at the project site is one of the most critical factors deciding the cost of wind generated

electricity. Fig 4 shows the effect of the average wind velocity at a site on the cost of unit energy produced. As the average velocity increases from 7 m/s to 9.5 m/s, the cost is reduced by 50 per cent (from 5 cents to 2.5 cents per kWh).

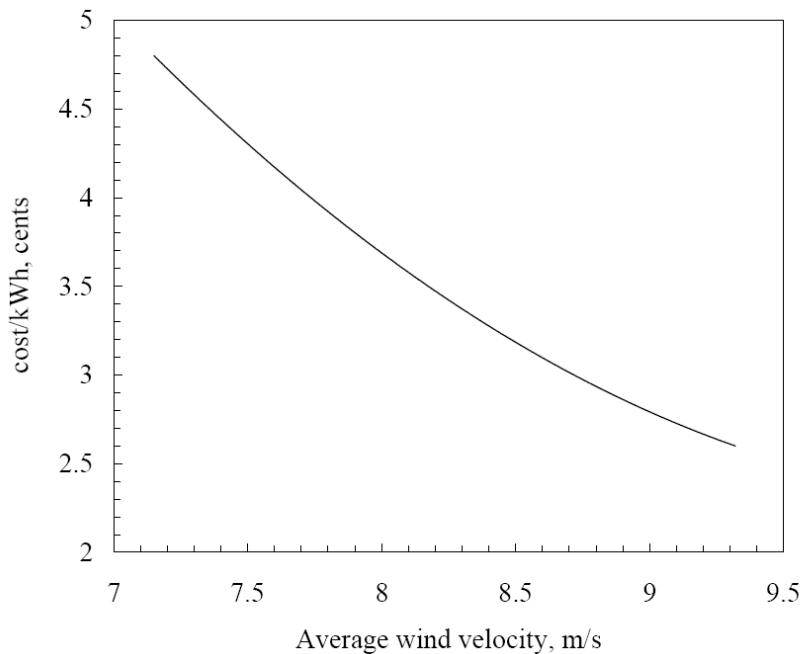

Figure 4: Effect of wind velocity on the cost of wind generated electricity

Cost of land, installation charges and labor wages vary from place to place. Expenditure on foundation, distance from the existing grid (additional cost for transmission distribution network) should also be taken into the calculations. Extending access from wind farm to existing highways would also contribute to the cost, which may vary from site to site. As the wind velocity increases with height, systems with taller towers generally produce more power. Towers are one of the costly items in a wind energy system.

4.2.1.2 MACHINE PARAMETERS

Cost of the wind turbines can be considerably reduced by scaling up the system size. This means that the cost per kW of a 2 MW machine is lower than that of a 2 kW unit. Unit cost of wind turbines dropped from \$ 2500/kW to \$ 750/kW in the last 20 years. This cost reduction is achieved mainly through scaling up the turbine size. Thus, transition of wind energy technology from small units in the earlier days to the MW capacity machines today, has resulted in reducing the cost of wind-generated electricity.

4.2.2 LIFE CYCLE COST ANALYSIS

In the life cycle based analysis, we look at a system or technology in its totality and account the energy use and related emissions involved in all the stages of its production, use and disposal. This essentially should include the extraction of raw materials, its conversion into different components, manufacturing, commissioning and operation of the system, and finally its disposal or recycling after use. Fig 5 shows an example for life cycle analysis of a typical wind turbine. When we assess such systems, it is logical to account the energy flow and emission potential of all the phases of the project life as indicated in the figure. Here, upto the phase of turbine manufacturing, energy of various forms are consumed and thus the system will have a negative impact on environment. In contrast, during the operational phase, energy is being generated without any pollution and thus the project reacts positively to the environment.

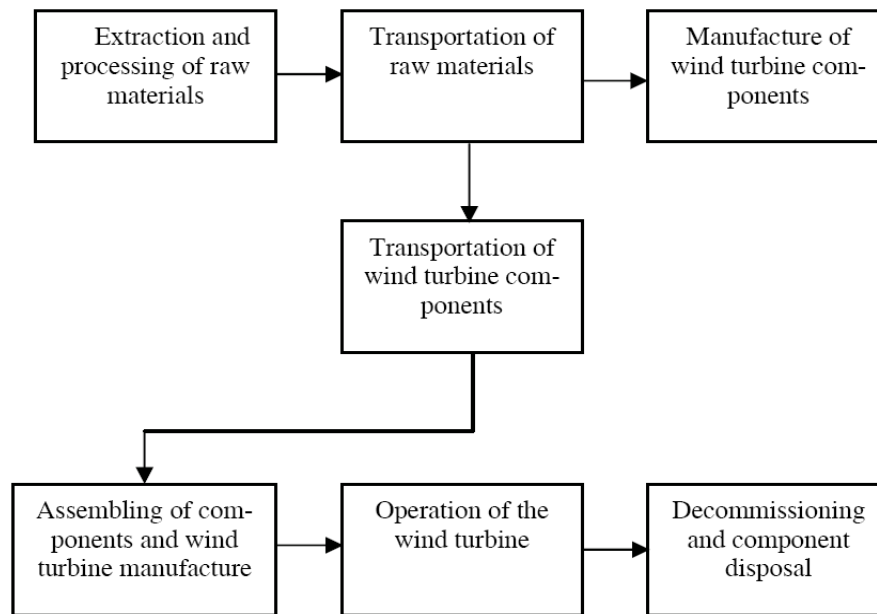

Figure 5: Various stages of life cycle of wind energy systems

Sample questions

1. Estimate the CO₂ mitigation potential of a wind farm with 5 turbines of 1 MW rated capacity. The cut-in, rated and cut-out velocities of the turbines are 4, 12 and 25 m/s respectively. The Weibull shape and scale factors at the wind farm location are 3 and 8 m/s respectively. The CO₂ emission from coal based power plant is 0.82 kg/kWh.
2. Cost of a 600 kW wind turbine is \$ 550000. Other initial costs including that for installation and grid integration are 30 per cent of the turbine cost. Useful life of the system is 20 years. Annual operation and maintenance costs plus the land rent come to 3.5 per cent of the turbine cost. Calculate the cost of generating electricity from the turbine when it is installed at a site having a capacity factor of 0.25. The real rate of interest may be taken as 5 per cent.
3. Illustrate the effect of capacity factor on the cost/kWh in the above example. If a utility company buys the generated electricity at a rate of \$ 0.03/kWh, find out the break-even capacity factor.

Suggested reading references

16. Jain P. Wind Energy Engineering. McGraw-Hill, New York, 2011
17. Jha AR. Wind Turbine Technology. CRC Press, Taylor & Francis Group, 2011
18. Johnson GL. Wind Energy Systems (Electronic Edition), Prentice Hall Inc, 2006
19. Mathew S. Wind Energy: Fundamentals, Resource Analysis and Economics, Springer, 2006.
20. Burton T. Sharpe D. Jenkins N. Bossanyi E. Wind Energy Handbook. John Wiley, 2001

DRE 104: WIND AND HYDRO ENERGY

UNIT-5: HYDRO-POWER

UNIT STRUCTURE

INTRODUCTION

5.1 CLASSIFICATION OF HYDROPOWER PLANTS

5.2 SELECTION OF SITE FOR HYDROELECTRIC PLANT

INTRODUCTION

The idea of using water as a source of mechanical energy existed since the ages of prehistoric times. The hydraulic energy was first converted into mechanical energy in India about 2200 years back by passing the water through water wheels. These water wheels were originally made of wood and are seen in technical museums even now. Such type of water wheels were taken from India to Egypt and then to European countries and finally to America. It is believed that the water wheel was used in Europe about 500 years after its origin in India.

Hydropower is a very clean source of energy. It does not consume but only uses the water, after use it is available for other purposes. The conversion of the potential energy of water into mechanical energy is a technology with a high efficiency. The use of hydropower can make a contribution to savings on exhaustible energy sources. Each 600 kWh of electricity generated with a hydro plant is equivalent to 1 barrel of oil.

5.1 CLASSIFICATION OF HYDROPOWER PLANTS

Hydroelectric power plants can be classified in the following way:

- *According to the availability of head*
 - (a) High head power plants
 - (b) Medium head power plants
 - (c) Low head power plants
- *According to the nature of load* (a) Base load plants
 - (b) Peak load plants
- *According to the quality of water available*
 - (a) Run- of river plant without pondage
 - (b) Run- of river plant with pondage
 - (c) Hydroelectric plants with storage reservoirs
 - (d) Pump storage plants
 - (e) Mini and micro hydel plants

High head power plants

These plants work under a head of 100 m and above. Water is stored in lakes or high mountains during rainy season or when snow melts. Surplus water is discharged by a spillway. Tunnel through the mountain has a

surge chamber and regulating valves at its exit. Pelton wheel is the common prime mover.

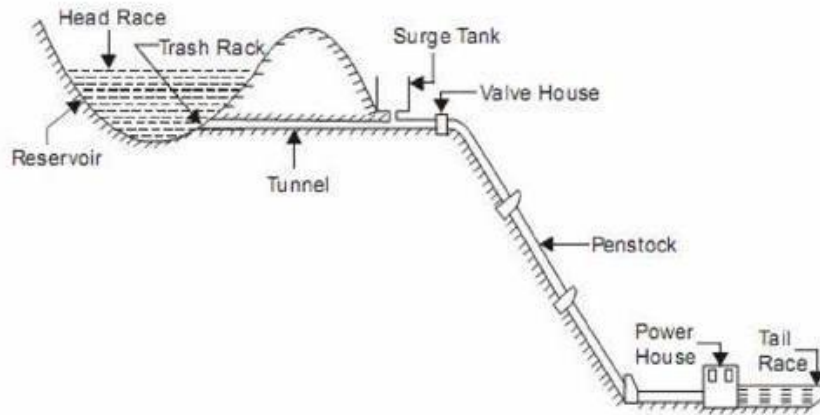

Figure 1 High head power plants

Medium head power plants

These plants operate under heads varying from 30m to 100m. Francis turbine is the common prime mover. Forebay before the penstock acts as the water reservoir and also as a surge tank.

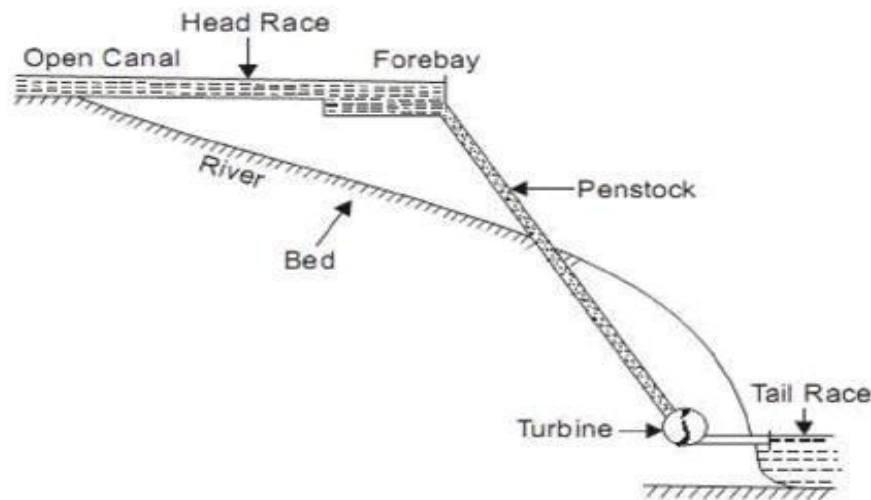

Figure 2 Medium head power plants

Low head power plants

A dam is constructed across a river and a sideways stream diverges from the river at the dam. Later this channel joins the river further downstream. Francis turbine or Kaplan turbine is used for power generation.

Base load plants

These plants are required to supply constant power to the grid. They run continuously without any interruption and are mostly remote controlled.

Peak load plants

They only work during certain hours of a day when the load is more than the average. Thermal stations work with hydel plants in tandem to meet the base load and peak load during various

seasons.

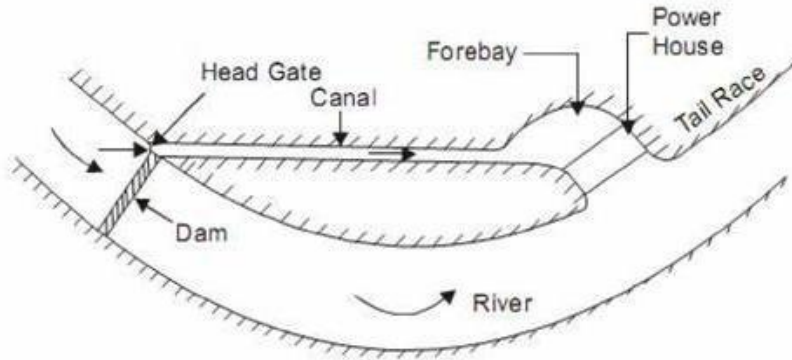

Figure 3 Low head power plants

Run- of river plant with or without pondage

Such a plant works daily according to the nature and limit to the flow in the river. Power generated depends on the quality of flow. Sometimes a small storage reservoir or pond is built which can store a few hours supply of water to the plant when the river flow exceeds the amount required by the plant. Such a scheme is called a run- of- river plant with pondage. The pondage or stored water is used in generating power during the hours when the demand is in excess of the flow of the river at the moment.

Hydroelectric plants with storage reservoirs

These plants are most common in India. During the rainy season water is stored in reservoirs so that it can be utilized during other seasons to supplement the flow of the river whenever the flow in the river falls below a specified minimum. Power can be generated directly from the reservoir. Sometimes canals are constructed to convey water from the reservoir for irrigation purposes.

Pump storage plants

Water after working in turbines is stored in the tailrace reservoir. During low load, the water is pumped back from the tail to the head reservoir drawing excess electricity from the grid or from the nearby steam plant. During peak load, this water is used to work on turbines to produce electricity. It is always economical to run the stream power plants all the time at full plant capacity factor. Whenever the load demand is less than the full plant capacity, the surplus energy instead of being wasted is transmitted to a pump is installed at the tailrace of the hydroelectric plant.

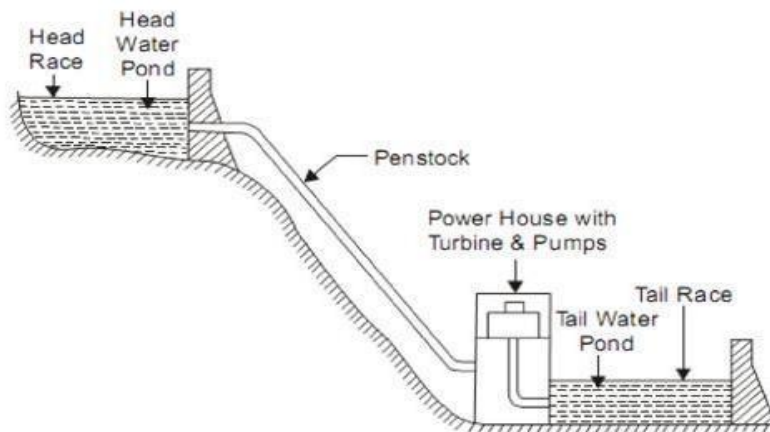

Figure 4 Pump storage plants

Mini and microhydel plants

More emphasis is now being given on such plants. The natural water source in hilly terrain can be utilized for power generation with low-head standardized turbo-generator units. Its adverse effect on ecology is negligible. The mini plants operate with 5 m- 20 m head producing about 1 MW to 5 MW of power, while micro plants are still smaller and work under a head of less than 5 m and generate electricity between 0.1 MW to 1MW[1]. The potential energy source in India in this category is around 20,000 MW.

Small Hydropower System

Small hydro (2001kW to 25000 kW) is the development of hydroelectric power on a scale serving a small community or industrial plant [2]. Hydro power upto 25MW station capacity is classified as small hydro power (SHP).

Status of Hydropower Worldwide

Hydropower constitutes 21% of the world's electricity generating capacity. The theoretical potential of worldwide hydropower is 2,800 GW, about four times greater than the 723 GW that has been exploited. Yet, the actual amount of electricity that will ever be generated by hydropower will be much lower than the theoretical potential, due to the environmental concerns and economic constraints. About 44 % of the world's hydropower was generated in four countries in 2002, mostly large- and mid-scale plants. Asia accounted for 24% of the world's hydro generation, with 618 GWh, followed by North America with 23% (595 GWh) and Europe with 20% (537 GWh). Canada with 315 GWh is the largest producer of hydropower in the world followed by China with 309 GWh. Brazil with 282 GWh and the United States with 255 GWh comes after them. Even though Canadian hydro generation is growing, In Western Europe and the United States, the scope for additional hydropower is limited, as the most economic sites have already been developed and further expansion is hindered by environmental concerns. In North America, hydropower is the most widely used form of renewable energy. The installed hydropower capacity amounts to 175 GW (67 GW in Canada, 99 GW in the US, and 10 GW in Mexico). Hydropower accounts for 57% of the electricity generated in Canada, 7% in the US (the US uses hydropower for peaking not base load) and 12% in Mexico. Canada's economical hydropower potential is second only to that of Brazil in the Western Hemisphere. Canada still has several projects under either construction or planning, amounting to 6.6 GW. Latin America has a very large hydropower potential. Many countries rely heavily on hydropower for their electricity supply. For instance, hydropower makes up 80% of Brazil's electricity generation. Brazil has plentiful hydropower resources. Its installed hydropower capacity is 64 GW. The capacity under construction or planning is more than 25 GW. One of the hydropower plants under construction is the giant 11.18 GW Belo Monte power plant. Hydropower capacity under construction or planning in other South American countries, particularly Argentina, Bolivia, Chile, Colombia, Guyana, Peru, and Venezuela, amounts to 9.7 GW. Also, 4.4 GW of hydropower capacity is under construction or planning in Central American countries. China has the largest hydropower resources in the world, with a huge territory and a host of rivers. It has installed hydropower capacity rest at 83 GW by the end of 2002. A large number of hydropower plants are under construction or planning, amounting to 77.7 GW. The giant 18.2 GW Three Gorges Dam with a dam height of 181 m on the Yangtze River (the country's longest river) is the world's largest hydropower project. Even though hydropower plants based on dams and reservoirs may require displacement and relocation of large numbers of people, China has one of the best resettlement programs in the world. Russia holds fifth place with 180 GWh and Norway in sixth with 125 GWh. Norway is regarded by many as having the best managed hydro system in the world, which accounts for 99.3% of the total power generated in that country. Although there are hydroelectric power projects under construction in about 80 countries, the majority of the

remaining hydro potential is found in developing countries particularly in South and Central Asia, Latin America and Africa. In most of the European countries the economically feasible hydro power potential has mostly been harnessed [3].

Advantages and Disadvantages of Hydropower

Hydropower has some inherent advantages which make it very attractive.

- Water source is perennially available. No fuel is required to be burnt to generate electricity. It is aptly termed as white coal. Water passes through turbines to produce work and downstream its utility remains undiminished for irrigation of farms and quenching the thirst of people in the vicinity.
- Running costs of hydropower installations are very low as compared to thermal or nuclear power stations.
- There is no problem with regards to the disposal of ash as in a thermal station.
- Hydraulic turbine can be switched on and off in a very short time.

- Hydro plants provide ancillary benefits like irrigation, flood control, afforestation, navigation and aqua- culture.

Major disadvantages of water power are the following:

- Hydro power projects are capital intensive with a low rate of return.
- Power generation is dependent on the quantity of water available, which may vary from season to season and year to year.
- Such plants are often far away from the load centre and require long transmission lines to deliver power.
- Large hydro plants disturb the ecology of the area, by way of deformation, destroying vegetation and uprooting people. Strong public opinion against erection of such plants is a deterrent factor.

5.2 SELECTION OF SITE FOR HYDROELECTRIC PLANT

While selecting a suitable site, if a good system of natural storage lakes at high altitudes and with large catchment areas can be located, the plant will be comparatively economical. Anyhow the essential characteristics of a good site are: large catchment areas, high average rainfall and a favorable place for constructing the storage or reservoir. For this purpose, the geological, geographical and meteorological conditions of a site need careful investigation. The following factors should be given careful consideration while selecting a site for a hydro-electric power plant:

Water Available

To know the available energy from a given stream or river, the discharge flowing and its variation with time over a number of years must be known. Preferably, the estimates of the average quantity of water available should be prepared on the basis of actual measurements of stream or river flow. The recorded observation should be taken over a number of years to know within reasonable, limits the maximum and minimum variations from the average discharge. The river flow data should be based on daily, weekly, monthly and yearly flow over a number of years. Then the curves or graphs can be plotted between the river flow and time. These are known as hydrographs and flow duration curves.

The plant capacity and the estimated output as well as the need for storage will be governed by the average

flow. The primary or dependable power which is available at all times when energy is needed will depend upon the minimum flow. Such conditions may also fix the capacity of the standby plant. The, maximum of flood flow governs the size of the headworks and dam to be built with adequate spillway.

Water-Storage

As already discussed, the output of a hydropower plant is not uniform due to wide variations of rain fall. To have a uniform power output, water storage is needed so that excess flow at certain times may be stored to make it available at the times of low flow. To select the site of the dam ; careful study should be made of the geology and topography of the catchment area to see if the natural foundations could be found and put to the best use.

Head of Water

The level of water in the reservoir for a proposed plant should always be within the limits for throughout the year.

Distance from Load Center

Most of the time the electric power generated in a hydro-electric power plant has to be used some considerable distance from the site of plant. For this reason, to be economical on transmission of electric power, the routes and the distances should be carefully considered since the cost of erection of transmission lines and their maintenance will depend upon the route selected.

Access to Site

It is always a desirable factor to have a good access to the site of the plant. This factor is very important if the generated electric power is to be utilized at or near the plant site. The transport facilities must also be given due consideration.

Hydrological cycle

Hydrology is the science that deals with the processes governing depletion and replenishment of water resources over and within the earth's surface. With the knowledge of hydrology at a certain site it is possible to design the irrigation and flood control works, power projects, water supply schemes, navigation works etc. As water vapour in atmospheric air goes up it cools, condenses and falls as rain, hail, snow or sleet. When this precipitation falls on hills and mountains and converges to form streams and rivers, it can be used for power generation. Intensity of rainfall, season and topography largely determine the usefulness of rainfall for power purposes. Light falls aid the growth of vegetation but do not contribute to stream flow. When total monthly precipitation concentrates in one or more storms, the runoff will increase greatly through vegetation may suffer. Distribution of precipitation may be classified as (i) direct evaporation (ii) absorption and transpiration by vegetation (iii) seepage and storage and (iv) direct surface runoff eventually forming rivers.

- (i) A major part of precipitation on land areas that reaches the soil re-evaporates to atmosphere, the rate being large from surface of lakes, ponds and swamps. A rise in temperature and drop in humidity increase the evaporation rate with the wind aiding it.
- (ii) Plants absorb water through their roots and transpire it as vapour through their leaves to the atmosphere.
- (iii) Precipitation absorbed by soil seeps or percolates into the ground, forming bodies of water called the water table or ground storage. It is also called infiltration which is a process by which water enters the surface strata of the soil and makes its way downwards to the water table. The amount of seepage

or infiltration depends on the geological character of the surface and subsoil.

- (iv) The remaining water flows over the ground surface as direct runoff to form brooks and rivers. The amount of runoff from a given rainfall depends on the nature of precipitation. Short, hard showers may produce relatively little runoff, whereas long rainfall saturates the soil lowering seepage rate and slows down evaporation by increased humidity and thus produces more runoff.

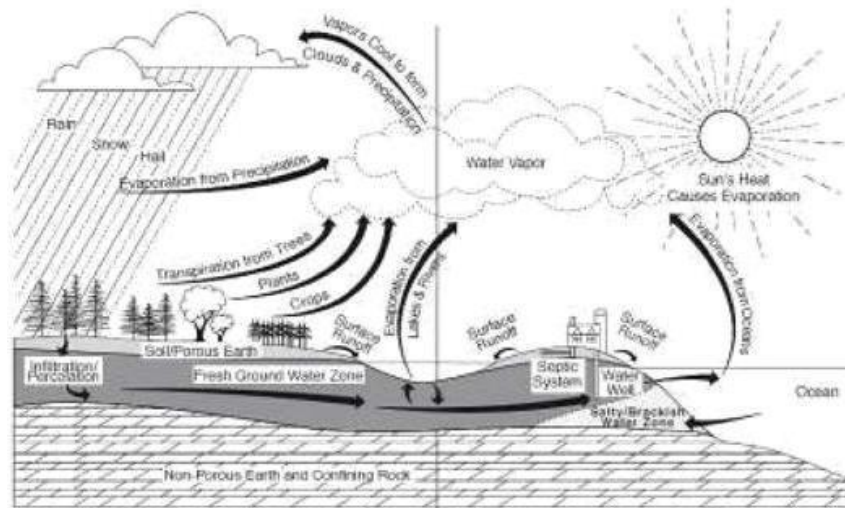

Figure 5 Hydrological cycle

References Suggested Reading

1. R. K. Rajput, "A text book of Power Plant Engineering", Laxmi Publication Ltd, New Delhi, 1995.
2. <http://inshp.org>
3. http://www.erg.com.np/hydropower_global.php
4. RK Bansal. A Textbook of fluid mechanics and hydraulic machines. Laxmi Publications, 2005, New Delhi
5. P K Nag, Power Plant Engineering, 3rd Edition, Tata McGraw Hill, 2008
6. Wagner H. Mathur J. Introduction to Hydro Energy systems: Basic, Technology and Operations, Springer, 2011

DRE 104: WIND AND HYDRO ENERGY

UNIT-6: BASICS OF FLUID MECHANICS

UNIT STRUCTURE

INTRODUCTION

- 6.1 CLASSIFICATION OF FLUIDS
- 6.2 TYPES OF FLUID FLOW
- 6.3 EQUATION OF CONTINUITY OF FLUID FLOW

INTRODUCTION

Fluid mechanics and hydraulics represent that branch of applied mechanics dealing with the behavior of fluids at rest and in motion. In the development of the principles of fluid mechanics some fluid properties play principal roles others only minor roles or no roles at all. In fluid statics, specific weight is the important property whereas in fluid flow density and viscosity are predominant properties. Where appreciable compressibility occurs, principles of thermodynamics must be considered. Vapor pressure becomes important when negative pressures (gage) are involved and surface tension affects static and flow conditions in small passages. Many techniques have been developed for the measurement of pressure and vacuum. Instruments used to measure pressure are called pressure gauges or vacuum gauges. A manometer could also be referring to a pressure measuring instrument, usually limited to measuring pressures near to atmospheric. The term manometer is often used to refer specifically to liquid column hydrostatic instruments. A vacuum gauge is used to measure the pressure in a vacuum.

Definition of Fluid

Fluids are substances which are capable of flowing and which conform to the shape of containing vessels. When in equilibrium, fluids cannot sustain tangential or shear forces. All fluids have some degree of compressibility and offer little resistance to change of form.

Fluids may be divided into liquids and gases. The main differences between liquids and gases are (i) liquids are practically incompressible whereas gases are compressible and often must be so treated and (ii) liquids occupy definite volumes and have free surfaces whereas a given mass of gas expands until it occupies all properties of any containing vessel.

6.1 CLASSIFICATION OF FLUIDS

A fluid which has no resistance to shear stress is known as an ideal fluid. Ideal fluid is also referred to as an *inviscid* (zero viscosity) fluid. Almost all real fluids have some resistance to stress and therefore are viscous.

Characteristic of Water

Physical Characteristics of Water

Turbidity

The turbidity is measured by a turbidity rod or by a turbidity meter with optical observations and is expressed as the amount of suspended matter in mg/l or parts per million (ppm). For water, ppm and mg/l are approximately equal. The standard unit is that which is produced by one milligram of finely divided silica

(fuller's earth) in one liter of distilled water.

Colour

The presence of colour in water is not objectionable from health point of view, but may spoil the colour of the clothes being washed. The standard unit of colour is that which is produced by one milligram of platinum cobalt dissolved in one liter of distilled water. For public supplies, the colour number on cobalt scale should not exceed 20 and should be preferably less than 10. Colour determined by an instrument is known as tintometer.

Taste and Odour

The extent of taste or odour present in a particular sample of water is measured by a term called odour intensity, which is related with the threshold odour or threshold odour number. Water to be tested is therefore gradually diluted with odour free water, and the mixture at which the detection of odour by human observation is just lost, is determined. The number of times the sample is diluted represents the threshold odour number. For public supplies, the water should generally free from odour, i.e. the threshold number should be 1 and should never exceed 3.

Temperature

For potable water, temperature of about 100C is desirable. It should not be more than 250C.

Specific Conductivity

The total amount of dissolved salts present in water can be easily estimated by measuring the specific conductivity of water.

Chemical Characteristics

Total Solids and Suspended Solids

Total solids (suspended solids + dissolved solids) can be obtained by evaporating a sample of water and weighing the dry residue left and weighing the residue left on the filter paper. The suspended solid can be found by filtering the water sample. Total permissible amount of solids in water is generally limited to 500ppm.

pH value of Water

$$pH = -\log[H^+] = \log\left[\frac{1}{H^+}\right]$$

If H^+ concentration increases, pH decreases and then it will be acidic. If H^+ concentration decreases, pH increases and then it will be alkaline.

$$[H^+][OH^-] = 10^{-14}$$

$$pH + pOH = 14$$

If the pH of water is more than 7, it will be alkaline and if it is less than 7, it will be acidic. The alkalinity is caused by the presence of bicarbonate of calcium and magnesium or by the carbonates of hydroxides of sodium, potassium, calcium and magnesium. Some, but not all of the compounds that cause alkalinity also cause hardness. The pH value of water can be measured quickly and automatically with the help of a Potentiometer. Permissible pH value for public supplies may range between 6.6 to 8.4. The lower value of pH may cause incrustation, sediment deposits, and difficulty in chlorination.

Hardness of Water

Hard waters are undesirable because they may lead to greater soap consumption, scaling of boilers, causing corrosion and incrustation of pipes, making food tasteless etc.

Temporary Hardness: If bicarbonates and carbonates of calcium and magnesium are present in water, the water is rendered hard temporarily as this hardness can be removed to some extent by simple boiling or to full extent by adding lime to water. Such hardness is known as temporary hardness or carbonate hardness.

Permanent Hardness: If sulphates, chlorides and nitrates of calcium or magnesium are present in water, they cannot be removed at all by simple boiling and therefore, such water requires special treatment for softening. Such hardness is known as permanent hardness or non-carbonate hardness. It is caused by sulphates, chlorides, nitrates of Ca and Mg.

Carbonate hardness = Total hardness or Alkalinity (whichever is less)

Non-carbonate hardness = Total hardness – Alkalinity

Chloride Content

The chloride content of treated water to be supplied to the public should not exceed a value of about 250ppm. The chloride content of water can be measured by titrating the water with standard silver nitrate solution using potassium chromate as indicator.

Nitrogen Content

The presence of nitrogen in water may occur in one or more of the following reasons:

- Free ammonia: It indicates very first stage of decomposition of organic matter. It should not exceed 0.15mg/l
- Albuminous or Organic Matter: It indicates the quantity of nitrogen present in water before the decomposition of organic matter has started. It should not exceed 0.3mg/l
- Nitrites: Not fully oxidized organic matter in water.
- Nitrates: It indicates fully oxidized organic matter in water (representing old pollution).
 - Nitrites are highly dangerous and therefore the permissible amount of nitrites in water should be nil.
 - Ammonia nitrogen + organic nitrogen = kjedhal nitrogen
 - Nitrates in water are not harmful. However the presence of too much of nitrates in water may adversely affect the health of infants causing a disease called methemoglobinemia commonly called blue baby disease.
 - The nitrate concentration in domestic water supplies is limited to 45mg/l.

Metal and other chemical substances in water

Iron – 0.3ppm, excess of these cause discolourations of clothes.

Manganese – 0.05ppm

Copper – 1.3ppm

Sulphate – 250 ppm

Fluoride – 1.5 ppm, excess of this affects human lungs and other respiratory organs.

Fluoride concentration of less than 0.8 – 1.0 ppm causes dental cavity (tooth decay). If fluoride concentration is greater than 1.5ppm, causing spotting and discolouration of teeth (a disease called fluorosis).

Dissolved gases

Oxygen gas is generally absorbed by water from the atmosphere but it being consumed by unstable organic matter for their oxidation. Hence, if the oxygen present in water is found to be less than its saturation level, it indicates presence of organic matter and consequently making the waters suspicious.

Biological Oxygen Demand (BOD): The extent of organic matter present in water sample can be estimated by supplying oxygen to this sample and finding the oxygen consumed by the organic matter present in water. This oxygen demand is known as Biological oxygen demand (BOD). It is not practically possible to determine ultimate oxygen demand. Hence, BOD of water during the first five days at 20°C is generally taken as the standard demand. The BOD of safe drinking water must be nil.

$BOD_5 = BOD \text{ of 5 days} = \text{Loss of oxygen in mg/l} \times \text{dilution factor.}$

Fluid Pressure

Fluid pressure is transmitted with equal intensity in all directions and acts normal to any plane. In the same horizontal plane the pressure intensities in a liquid are equal. If F is the force acting on area a , then intensity of pressure (or pressure) will be

$$p = \frac{F}{a}$$

It is obvious that the pressure can be expressed in either of the following two ways:

- As a force per unit area (i.e. kg/cm², kg/m² or N/mm², N/m²)
- As a height of the equivalent liquid column.

Pascal's Law

Pascal's law states that the intensity of pressure at any point in a fluid at rest is the same in all directions.

Applications

- Used for amplifying the force of the driver's foot in the braking system of most cars and trucks
- Used in artesian wells, water towers, and dams
- The underlying principle of the hydraulic press
- The siphon

Hydraulic press

Hydraulic press can lift a larger load by the application of a comparatively much smaller force. Hydraulic press consists of two cylinders, one larger and the other smaller, connected to a chamber containing some liquid. The larger cylinder contains a ram and the smaller one a plunger. A smaller force P acts on the plunger in downward direction which presses the liquid below it. This pressure is transmitted equally in all directions and raises the ram. The heavier load placed on the ram is then lifted up.

Pressure measurement

The pressure of a fluid is measured by the following devices

- Manometers
- Mechanical Gauges

Manometers: Manometers are the devices used for measuring the pressure at a point in a fluid by balancing the column of fluid by the same or another column of the fluid. The commonly used manometers are Piezometer, U tube manometer, U tube differential manometer.

Mechanical Gauges: Mechanical gauges are the devices used for measuring the pressure by balancing the fluid column by the spring or dead weight. The commonly used mechanical gauges are Diaphragm pressure gauge, Bourdon tube pressure gauge, Bellows pressure gauge, Dead weight pressure gauge.

Piezometer tube

The simplest form of manometer used for measuring moderate pressure is piezometer. One end of this manometer is connected to the point where pressure is to be measured and other end is open to the atmosphere. The rise of liquid gives the pressure head at that point.

Simple U tube Manometer

It is slightly improved form of Piezometer tube for measuring high as well as negative pressure of liquid. It consists of glass tube bent in U-shape, one end of which is attached to the gauge point and another is open to the atmosphere. Generally, Mercury which is 13.6 times heavier than water is used as liquid in Simple U tube Manometer.

Differential Manometer

It is the device used for measuring the difference of pressures, between two points in a pipe or in two different pipes. A differential manometer, in its simplest form, consists of a U-tube, containing heavy liquid, whose two ends are connected to the points, whose difference of pressure is required to be found out.

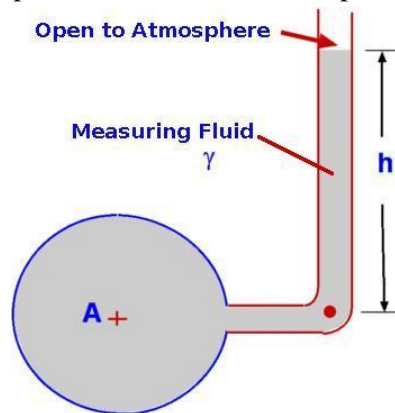

Figure 1 Piezometer tube

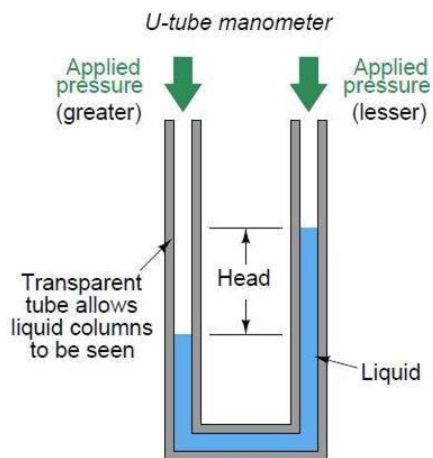

Figure 2 Simple U tube Manometer

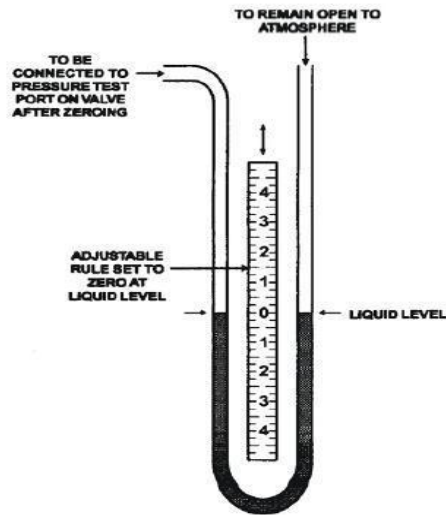

Figure 3 Double-column U-shaped differential manometer

6.2 TYPES OF FLUID FLOW

The fluid flow can be classified as

- Steady and unsteady flows
- Uniform and non-uniform flows
- Laminar and turbulent flows
- Compressible and incompressible flows
- Rotational and irrotational flows
- One, two and three dimensional flows

Steady and unsteady flows: Steady flow is that type of flow in which the fluid characteristics like density, viscosity etc do not change with time at a point. When fluid characteristics change with respect to time at a point then it is known as unsteady flow.

Uniform and non-uniform flows: When the velocity of flow at any given time does not change with respect to space (i.e. length of direction of flow), then it is known as uniform flow. Non uniform flow is that type of flow in which the velocity at any given time changes with respect to space.

Laminar and turbulent flows: A laminar flow is one in which paths taken by individual particles do not cross one another and moves along well defined paths. This type of flow is also called stream line flow or viscous flow.

Compressible and incompressible flows: Compressible flow is that type of flow in which density of the fluid changes from point to point. Incompressible flow is that type of flow in which density is constant for the fluid flow.

Rotational and irrotational flows: A flow is said to be rotational if the fluid particles while moving in the direction of flow rotate about their mass centers. Flow near the solid boundaries is rotational. A flow is said to be irrotational if the fluid particles while moving in the direction of flow do not rotate about their mass centers. Flow outside the boundary layer is generally considered irrotational.

One, two and three dimensional flows

One dimensional flow is that type of flow in which the flow parameter such as velocity is a function of time and one space co-ordinate only. Mathematically,

$$u = f(x), v = 0 \text{ and } w = 0$$

Where u , v and w are velocity components in x , y and z directions respectively

Two dimensional flow is that type of flow in which the velocity is a function of time and two rectangular space coordinators is called two rectangular space coordinates say x and y . Mathematically,

$$u = f_1(x, y); v = f_2(x, y) \text{ and } w = 0$$

Three dimensional flows is that type of flow in which the velocity is a function of time and three mutually perpendicular directions. But for a steady three dimensional flow the fluid parameters are functions of three space coordinates (x , y and z) only. Mathematically,

$$u = f_1(x, y, z); v = f_2(x, y, z) \text{ and } w = f_3(x, y, z)$$

Streamlines

Streamlines are imaginary curves drawn through a fluid to indicate the direction of motion in various sections of the fluid system. A tangent at any point on the curve represents the instantaneous direction of the velocity of the fluid particles at that point. The average direction of velocity may likewise be represented by tangents to streamlines. Since the velocity vector has a zero component normal to the streamline, it should be apparent that there can be no flow across a streamline at any point.

Path lines

The path followed by a fluid particle in motion is called a path line. Thus the path line shows the direction of a particle, for a certain period of time or between two given sections.

Turbulent flow

A turbulent flow is that flow in which fluid particles move in a zig zag way.

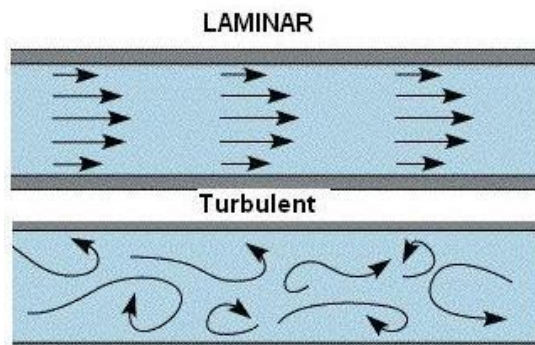

Figure 4 Laminar and Turbulent flow

6.3 EQUATION OF CONTINUITY OF FLUID FLOW

The equation of continuity results from the principle of conservation of mass. For steady flow, the mass of fluid passing all sections in a stream of fluid per unit of time is the same. This may be evaluated as

$$\rho_1 A_1 V_1 = \rho_2 A_2 V_2 = \text{Constant}$$

For incompressible fluids, where $\rho_1 = \rho_2$, the equation becomes

$$Q = A_1V_1 = A_2V_2 = \text{Constant}$$

Where A_1 and V_1 are respectively the cross sectional area and average velocity of stream at section 1, with similar terms for section 2 and Q is the discharge or rate of flow.

Bernoulli's theorem

The energy equation results from application of the principle of conservation of energy to fluid flow. The energy possessed by a flowing fluid consists of energies due to pressure, velocity and position. Bernoulli's theorem states as follow: *In an ideal incompressible fluid when the flow is steady and continuous, the sum of pressure energy, kinetic energy and potential (or datum) energy is constant along a stream line at any point.*

Mathematically; we can write

$$\frac{P}{\rho g} + \frac{V^2}{2g} + z = \text{constant}$$

Where

$$\frac{P}{\rho g} = \text{Pressure energy per unit weight of fluid or pressure head}$$

$$\frac{V^2}{2g} = \text{Kinetic energy per unit weight or kinetic head}$$

$$z = \text{Potential energy per unit head or potential head}$$

Assumptions

The following are the assumptions made in the derivation of Bernoulli's equation:

- The fluid is ideal
- The flow is steady
- The flow is incompressible
- The flow is irrotational

Limitations of Bernoulli's theorem

The Bernoulli's theorem or Bernoulli's equation has been derived on certain assumptions, which are rarely possible. Thus the Bernoulli's theorem has the following limitations:

- The Bernoulli's equation has been derived under the assumption that the velocity of every particle, across any cross section of a pipe is uniform. But in actual practice, it is not so.
- The Bernoulli's equation has been derived under the assumption that no external force except the gravity force is acting on the liquid. But in actual practice, it is not so.
- The Bernoulli's equation has been derived under the assumption that there is no loss of energy of the liquid particle while flowing. But in actual practice, it is rarely so.
- If the liquid is flowing in a curved path, the energy due to centrifugal force should also be taken into account.

Bernoulli's equation has a number of practical applications. Here, we shall discuss its application on the following hydraulic devices like (i) Venturi meter (ii) Orifice meter and (iii) Pitot tube

Cavitations

Low pressures are commonly encountered on the suction side of the pump, with the possibility of cavitation occurring in the pump. Cavitation occurs when the liquid pressure at a given location is reduced to the

vapour pressure of the liquid. When this occurs, vapour bubbles formed. This phenomenon can cause a loss in efficiency as well as structural damage to the pump, when these bubbles collide with the metal surface. The cavitation has to be avoided in the pump. To characterize potential for cavitation the difference between the total head on suction side and vapour pressure head is used. The difference is called net positive suction head (NPSH). Total head near the pump impeller is

$$\frac{P_s}{\gamma} + \frac{V_s^2}{2g}; \text{ where } P_s \text{ is suction pressure and } V_s \text{ is velocity of liquid}$$

Liquid vapour pressure head is

$$\frac{P_v}{\gamma}; \text{ where } P_v \text{ is vapour pressure at the location}$$

Hence, the NPSH will be

$$NPSH = \frac{P_s}{\gamma} + \frac{V_s^2}{2g} - \frac{P_v}{\gamma}$$

Venturi meter

Bernoulli's equation can be applied to measure flow rate in a pipe by venturi meter. The venturi meter has three important portions: a converging part, constant area (throat) and a diverging part as shown in the Figure 5.

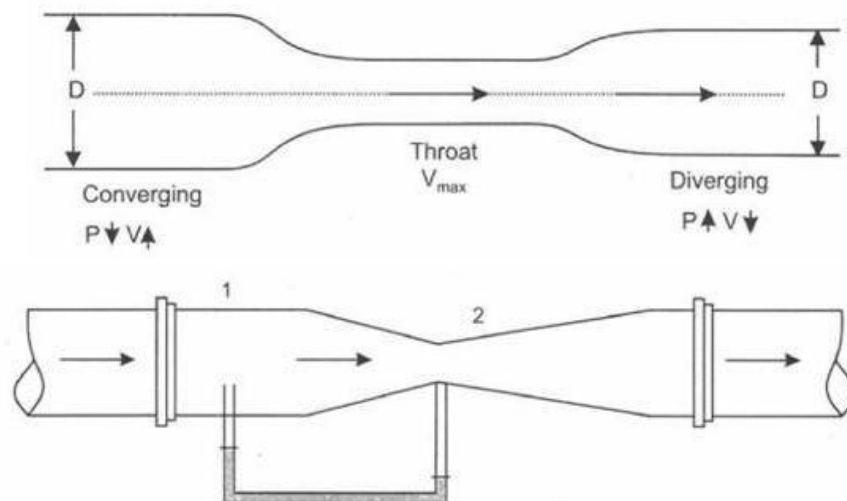

Figure 5 Venturi meter

We assume the flow is horizontal i.e., $Z_1 = Z_2$, flow is steady, inviscid and incompressible between the points 1 and 2 shown in Figure 5 of a venturi meter. It consists of a short converging conical tube leading to cylindrical portion called the throat, followed by diverging section in which diameter increases again to that of the main pipeline. The pressure difference is measured between points 1 and 2 by a suitable U-tube manometer. In the converging part pressure decreases and therefore according to Bernoulli equation velocity increases. In the diverging portion pressure increases and velocity decreases and in constant area velocity is maximum and pressure minimum. Applying Bernoulli equation between 1 and 2 points,

$$\frac{P_1}{\gamma} + \frac{V_1^2}{2g} = \frac{P_2}{\gamma} + \frac{V_2^2}{2g}$$

$$V_2^2 - V_1^2 = \frac{2g(P_1 - P_2)}{\rho g}$$

$$a_1 V_1 = a_2 V_2; \text{ or } V_2 = \frac{a_1}{a_2} V_1$$

For continuous flow

Now substituting V2 in the above equation; we will obtain

$$V_1 = \frac{a_2}{\sqrt{a_1^2 - a_2^2}} \sqrt{\frac{2g(P_1 - P_2)}{\rho g}}$$

Now, we know the volume flow rate $Q = a_1 V_1$; Now the above expression can be written as

$$Q = \frac{a_2 a_1}{\sqrt{a_1^2 - a_2^2}} \sqrt{2gH}$$

$$H = \frac{P_1 - P_2}{\rho g}$$

Where

Now, if $m = \text{area ratio} = a_1/a_2$; we can rewrite the above expression,

$$Q = \frac{a_1}{\sqrt{m^2 - 1}} \sqrt{2gH}$$

We can also write the above expression in the following way;

$$Q = a_2 \sqrt{\frac{2(P_1 - P_2)}{\rho \left[\left(1 - \frac{a_2}{a_1}\right)^2 \right]}}$$

In practice, some loss of energy occurs between points 1 and 2 and therefore the actual discharge (Q_a) will be less than theoretical discharge (Q) and therefore a coefficient of discharge C_d is expressed in the flowing way.

$$C_d = \frac{\text{Actual discharge}}{\text{Theoretical discharge}} = \frac{Q_a}{Q}$$

The value of C_d is around 0.98. The venturi meters are commonly used in power plants and chemical industries to measure the flow rate of pipes with fairly good accuracy. Thus for a given flow geometry (a_1 and a_2); the flow rate can be determined by measuring the difference of pressures P_1 and P_2 .

Orifice meter

An orifice meter is used to measure the discharge in a pipe. An orifice meter, in its simplest form, consists of a plate having a sharp edged circular hole known as an orifice. This plate is fixed inside a pipe. A mercury manometer is inserted to know the difference of pressures between the pipe and throat (i.e. orifice).

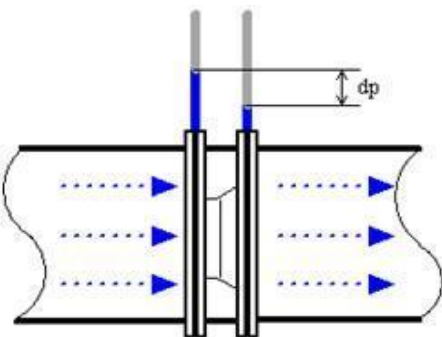
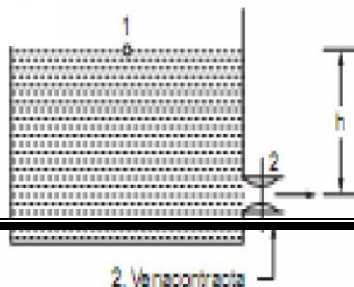

Figure 6A Orifice meter



From the above Figure, it shows an orifice in an open tank through which the flow takes place. Bernoulli equation between 1 and 2

$$\frac{P_1}{\rho g} + \frac{v_1^2}{2g} + z_1 = \frac{P_2}{\rho g} + \frac{v_2^2}{2g} + z_2$$

The velocity at point 1 is zero and the pressures at 1 and 2 are both atmospheric. Or, the above relation can be written as;

$$z_1 - z_2 = \frac{v_2^2}{2g}$$

$$v_2 = \sqrt{2g(z_1 - z_2)} = \sqrt{2gh}$$

The theoretical flow rate is given by

$$Q_T = A_2 \sqrt{2gh}$$

Where, A_2 is the area of cross section at discharge side. The actual flow rate can be written as

$$Q_{actual} = C_d A_o \sqrt{2gh}$$

Where, A_o is the area of orifice and C_d is the coefficient of discharge. The coefficient of discharge can be written as;

$$C_d = \frac{Q_{actual}}{Q_{theoretical}}$$

The value of C_d depends upon the contraction of jets from the orifice to section 2 and on non ideal flow effects such as head losses which depend upon the roughness of the inner surface of the tank near the orifice and the flow rate. Typical value for C_d is 0.62.

Co- efficient of velocity (Cv): There is always some loss of energy due to viscous effects in real fluid flows. Due to these effects, the actual flow velocity through the orifice will always be less than the theoretical possible velocity. The co-efficient of velocity (CV) is defined as follows:

$$C_v = \frac{\text{Actual velocity of jet at vena contracta}}{\text{Theoretical velocity}}$$

$$C_v = \frac{V}{\sqrt{2gh}}$$

The value of CV varies from 0.95 to 0.99 for different orifice depending on their shape and size.

Co- efficient of contraction (Cc) : As water leaves an open tank through an orifice, the stream lines converge and the area just outside the orifice is lower compared to the area of the orifice. This section is called vena contracta. Area of jet at the vena contracta is less than the area of the orifice itself due to convergence of stream lines. The co-efficient of contraction (Cc) is defined as follows:

$$C_c = \frac{\text{Area of the jet at vena contracta}}{\text{Area of orific}}$$

$$C_c = \frac{a_c}{a}$$

The value of coefficient of contraction varies from 0.61 to 0.69 depending on the shape and size of the orifice.

Co- efficient of discharge (Cd): Coefficient of discharge is defines as

$$C_d = \frac{\text{actual discharge}}{\text{theoretical discharge}} = \frac{\text{actual area}}{\text{theoretical area}} \times \frac{\text{actual velocity}}{\text{theoretical velocity}} = C_c \times C_v$$

The average of value of Cd for orifices is about 0.62.

Pitot tube

A Pitot tube is an instrument to determine the velocity of flow at the required point in a pipe or a stream. In its simplest form, a Pitot tube consists of a glass tube bent through 90°. The lower end of the tube faces the direction of the flow. The liquid rises up in the tube due to the pressure exerted by the flowing liquid. By measuring the rise of liquid in the tube, we can find out the velocity of the liquid flow.

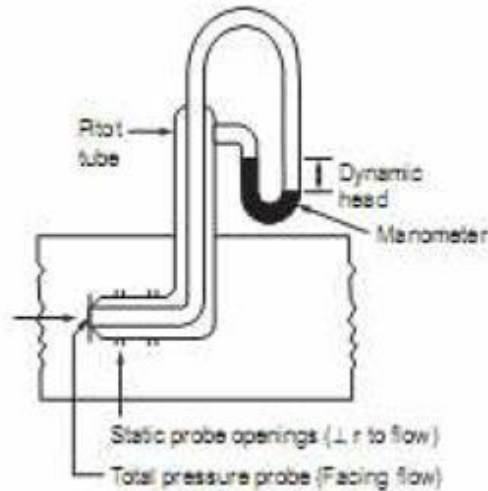

Figure 7 Pitot tube

Suggested Reading References

1. RK Bansal. A Textbook of fluid mechanics and hydraulic machines. Laxmi Publications, 2005, New Delhi
2. AZ Hussain. MZ Alimuddin. Basic fluid mechanics and Hydraulic Machines, CRC Press, 2009
3. P K Nag, Power Plant Engineering, 3rd Edition, Tata McGraw Hill, 2008
4. Wagner H. Mathur J. Introduction to Hydro Energy systems: Basic, Technology and Operations, Springer, 2011

DRE 104: WIND AND HYDRO ENERGY

UNIT-7: COMPONENTS OF HYDROPOWER PLANTS

UNIT STRUCTURE

INTRODUCTION

- 7.1 COMPONENTS OF HYDROPOWER PLANTS
- 7.2 HYDRAULIC TURBINES: TYPES AND OPERATIONAL ASPECTS
 - 7.2.1 CLASSIFICATION OF HYDRAULIC TURBINES
- 7.3 SPILLWAY, SURGE CHAMBERS, PENSTOCK, TAILRACE
- 7.4 TYPES OF GENERATORS - SYNCHRONOUS AND INDUCTION, DISTRIBUTION SYSTEM TRANSFORMERS, PROTECTION & CONTROL, TRANSMISSION AND

INTRODUCTION

When rain water falls over the earth's surface, it possesses potential energy relative to sea or ocean towards which it flows. If at a certain point, the water falls through an appreciable vertical height, this energy can be converted into shaft work. As the water falls through a certain height, its potential energy is converted into kinetic energy and this kinetic energy is converted to mechanical energy by allowing the water to flow through the hydraulic turbine runner. This mechanical energy is utilized to run an electric generator which is coupled to the turbine shaft. The power developed in this manner is given as

$$Power = W \times Q \times H \times \eta$$

Where W = Specific weight of water (N/m³)

Q = Water flow rate (m³/s)

H = Height of fall or head (m)

η = efficiency of conversion of potential energy to mechanical energy

7.1 COMPONENTS OF HYDROPOWER PLANTS

A simplified flow sheet of a water power plant is shown in Figure 1. The essential features of a water power plant are as below:

- Catchment area
- Reservoir
- Dam and intake house
- Inlet water way
- Power house
- Tail race or outlet water way

Catchment Area: The catchment area of a hydro plant is the whole area behind the dam, draining into a stream or river across which the dam has been built at a suitable place.

Reservoir: Whole of the water available from the catchment area is collected in a reservoir behind the dam. The purpose of the storing of water in the reservoir is to get a uniform power output throughout the year. A reservoir can be either natural or artificial. A natural reservoir is a lake in high mountains and an artificial reservoir is made by constructing a dam across the river.

Dam and Intake House: A dam is built across a river for two functions: to impound the river water for storage and to create the head of water. Dams may be classified according to their structural materials such as: Timber, steel, earth, rock filled and masonry. Timber and steel are used for dams of height 6 m to 12 m only. Earth dams are built for larger heights, upto about 100 m. To protect the dam from the wave erosion, a protecting coat of rock, concrete or planking must be laid at the water line. The other exposed surfaces should be covered with grass or vegetation to protect the dam from rainfall erosion. Beas dam at Pong is a 126.5 m high earth core-gravel shell dam in earth dams; the base is quite large as compared to the height. Such dams are quite suitable for a pervious foundation because the wide base makes a long seepage path.

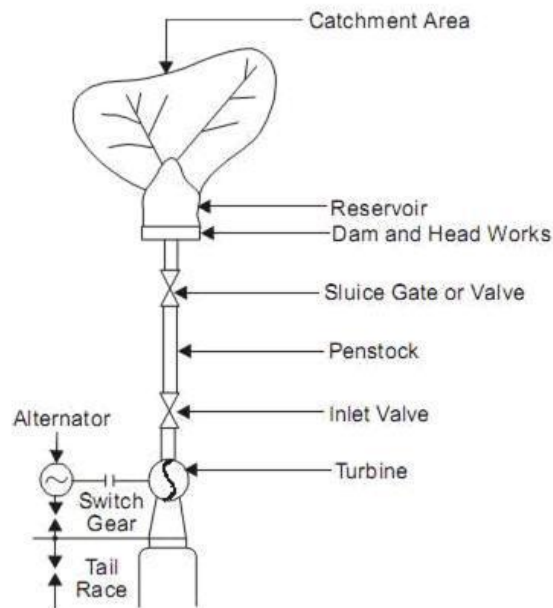

Figure 1 Components of hydropower plants

The earth dams have got the following advantages.

- Suitable for relatively pervious foundation.
- Usually less costly than a masonry dam.
- If protected from erosion, this type of dam is the most permanent type of construction.
- It fits best in natural surroundings.

The following are the disadvantages of earth dams:

- Greater seepage loss than other dams.
- The earth dam is not suitable for a spillway; therefore, a supplementary spillway is required.
- Danger of possible destruction or serious damage from erosion by water either seeping through it or overflowing the dam.

The masonry dams are of three major classes: solid gravity dam, buttress dam and the arched dam.

The buttress or deck dam has an inclined upstream face, so that water pressure creates a large downward force which provides stability against overturning or sliding. An arch dam is preferable where a narrow canyon width is available. It can be anchored well and the water pressure against the arch will be carried by less concrete than with a straight gravity type. This dam has the inherent stability against sliding. The most commonly used dams are shown in figure 2.

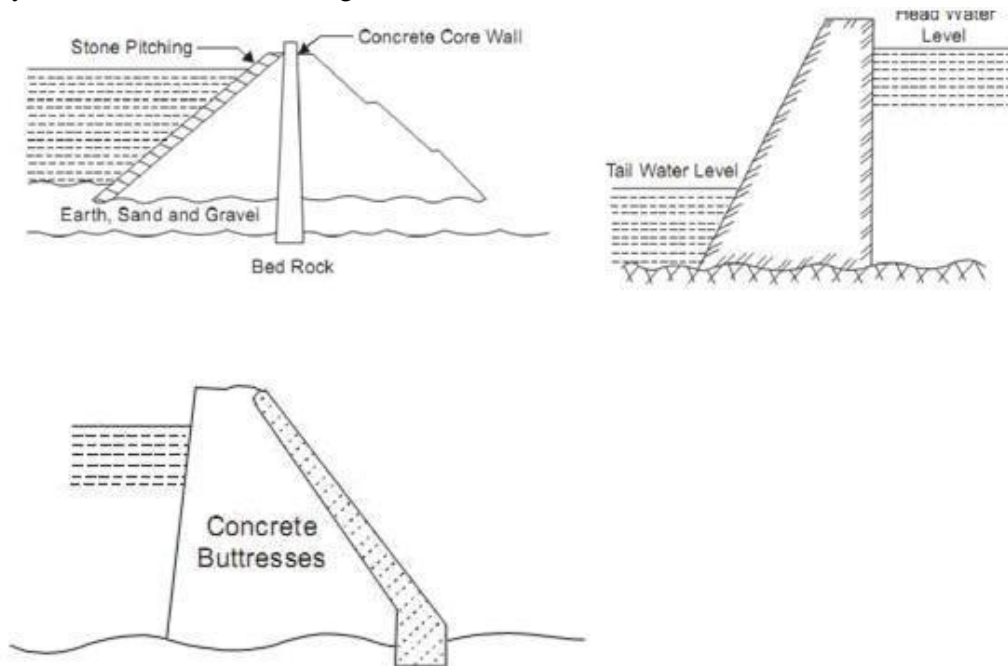

Figure 2 Types of Dams

Dams must be able to pass the flood water to avoid damage to them. This may be achieved by: spillways, conduits piercing the dam and the tunnels by passing the dam.

The intake includes the head works which are the structures at the intake of conduits, tunnels or flumes. These structures include booms, screens or trash racks, sluices for bypassing debris, and gates or valves for controlling the water flow. Booms prevent the ice and floating logs from going into the intake by diverting them to a bypass chute. Booms consist of logs tied end to end and form a floating chain. Screens or trash racks are fitted directly at the intake to prevent the debris from going into the intake. Debris cleaning devices should also be fitted on the trash racks. Gates and valves control the rate of water flow entering the intake.

The different types of gates are radial gates, sluice gates, wheeled gates, plain sliding gates, crest gates, rolling or drum gates etc. The various types of valves are rotary, spherical, butterfly or needle valves. A typical intake house is shown in figure 3. An air vent should be placed immediately below the gate and connected to the top of the penstock and taken to a level above the head water. When the head gates are closed and the water is drawn off through the turbines, air will enter into the penstock through the air vent and prevent the penstock vacuum which otherwise may cause collapsing of the pipe. A filler gate is also provided to balance the water pressure for opening the gate.

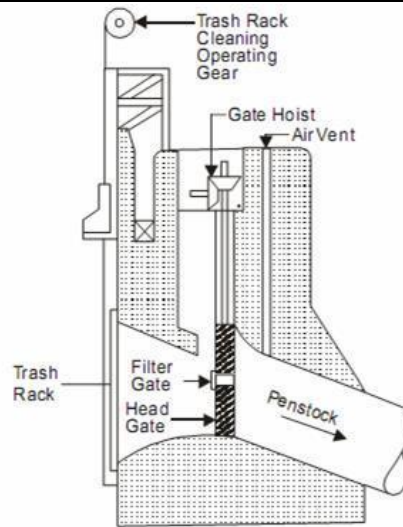

Figure 3 Typical intake house

Inlet Water Ways: Inlet water ways are the passages, through which the water is conveyed to the turbines from the dam. These may include tunnels, canals, flumes, forebays and penstocks and also surge tanks. A forebay is an enlarged passage for drawing the water from the reservoir or the river and giving it to the pipe lines or canals. Tunnels are of two types: pressure type and non-pressure type. The pressure type enables the fall to be utilized for power production and these are usually lined with steel or concrete to prevent leakages and friction losses. The non-pressure type tunnel acts as a channel. The use of the surge tank is to avoid water hammer in the penstock. Water hammer is the sudden rise in pressure in the penstock due to the shutting off the water to the turbine. This sudden rise in pressure is rapidly destroyed by the rise of the water in the surge tank otherwise it may damage or burst the penstock.

Power House: The power house is a building in which the turbines, alternators and the auxiliary plant are housed.

Tail Race or Outlet Water Way: Tail race is a passage for discharging the water leaving the turbines, into the river and in certain cases, the water from the tail race can be pumped back into the original reservoir.

7.2 HYDRAULIC TURBINES: TYPES AND OPERATIONAL ASPECTS

A hydraulic turbine is a prime mover that uses the energy of flowing water and converts it into the mechanical energy. Most of the electrical generators are powered by turbines. About 20% of power is generated by hydraulic turbines and hence their importance. Hydraulic power depends on renewable source and hence is ever lasting. It is also none polluting in terms of non generation of carbon dioxide. More general classification of hydraulic turbines is: (i) impulse turbines (Pelton Wheel) (ii) reaction turbine (Francis, Kaplan)

Impulse turbines are driven by one or two high velocity jets. Each jet is accelerated in a nozzle external to the turbine wheel known as turbine rotor. If friction and gravity are neglected the fluid pressure and relative velocity do not change as it passes over the blades/buckets.

In reaction turbines the available potential energy is progressively converted in the turbines rotors and the reaction of the accelerating water causes the turning of the wheel. These are again divided into radial flow, mixed flow and axial flow machines. Radial flow machines are found suitable for moderate levels of

potential energy and medium quantities of flow. The axial machines are suitable for low levels of potential energy and large flow rates. The potential energy available is generally denoted as “head available”. With this terminology plants are designated as “high head”, “medium head” and “low head” plants.

7.2.1 CLASSIFICATION OF HYDRAULIC TURBINES

The hydraulic turbines are classified as follows:

- According to the head and quantity of water available
- According to the name of the originator
- According to the action of the water on moving blades
- According to the direction of flow of water in the runner
- According to the disposition of the turbine shaft
- According to the specific speed

According to the head and quantity of water available

- Impulse turbines: - requires high head and small quantity of flow
- Reaction turbines:- requires low head and high rate of flow

Actually there are two types of reaction turbines, one for medium head and medium flow and the other for low head and large flow.

According to the name of the originator

- Pelton Wheel: - named after Lester Allen Pelton of California (USA.). It is an impulse type of turbine and is used for high head and low discharge.
- Francis turbine: - named after James Bichens Francis. It is a reaction type of turbine from medium high to medium low heads and medium small to medium large quantities of water.
- Kaplan turbine: - named after Dr. Victor Kaplan. It is a reaction type of turbine for low heads and large quantities of flow.

According to the action of the water on moving blades

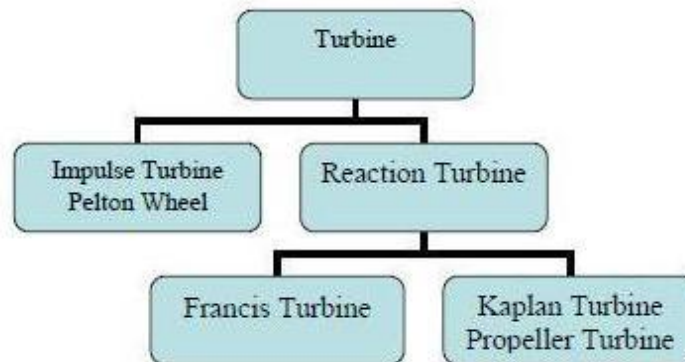

According to the direction of flow of water in the runner

- Tangential flow turbines (Pelton wheel)
- Radial flow turbine (no more used)
- Axial flow turbine (Kaplan turbine)
- Mixed (radial and axial) flow turbine (Francis turbine)

In tangential flow turbines of Pelton type the water strikes the runner tangential to the path of rotation. In axial flow turbine water flows parallel to the axis of the turbine shaft. Kaplan turbine is an axial flow turbine. In Kaplan turbine the runner blades are adjustable and can be rotated about pivots fixed to the boss of the runner. If the runner blades of the axial flow turbines are fixed, these are called “propeller turbines”. In mixed flow turbines the water enters the blades radially and comes out axially, parallel to the turbine shaft. Modern Francis turbines have mixed flow runners.

According to the disposition of the turbine shaft

Turbine shaft may be either vertical or horizontal. In modern practice, Pelton wheels usually have horizontal shafts whereas the rest, especially the large units, have vertical shafts.

According to the specific speed

The specific speed of a turbine is defined as the speed of a geometrically similar turbine that would develop 1 kW under 1m head. All geometrically similar turbines (irrespective of the sizes) will have the same specific speeds when operating under the same head.

$$N_s = \frac{N\sqrt{P}}{H^{5/4}}$$

Where N= The normal working speed
P= Power output of the turbine
H= the net or effective head

Significance of specific speed

Specific speed does not indicate the speed of the machine. It can be considered to indicate the flow area and shape of the runner. When the head is large, the velocity when potential energy is converted to kinetic energy will be high. The flow area required will be just the nozzle diameter. This cannot be arranged in a fully flowing type of turbine. Hence the best suited will be the impulse turbine. When the flow increases, still the area required will be unsuitable for a reaction turbine. So multi jet unit is chosen in such a case. As the head reduces and flow increases purely radial flow reaction turbines of smaller diameter can be chosen. As the head decreases still further and the flow increases, wider rotors with mixed flow are found suitable. The diameter can be reduced further and the speed increased up to the limit set by mechanical design. As the head drops further for the same power, the flow rate has to be higher. Hence axial flow units are found suitable in this situation. Keeping the power at constant, the specific speed increases with N and decreases with head. The speed variation is not as high as the head variation. Hence specific speed value increases with the drop in available head. This can be easily seen from the values listed in table 1.

Table1 Best specific Speed Range for Different Type of Hydraulic Turbines

Dimensionless specific speed range	Dimensional specific speed (SI System)	Type of turbine having the best efficiency at these value
0.015-0.053	8-29	Single jet Pelton turbine
0.047-0.072	26-40	Twin jet Pelton turbine
0.072-0.122	40-67	Multiple jet Pelton turbine
0.122-0.819	67-450	Radial flow turbine Francis type (H<350m)
0.663-1.66	364-910	Axial flow Kaplan turbine(H<60m)

Differences between impulse and reaction turbines

Sl. No	Aspects	Impulse turbine	Reaction turbine
1	Conversion of fluid energy	The available fluid energy is converted in kinetic energy by a nozzle	The energy of the fluid is partly transformed in K.E. before it (fluid) enters the runner of the turbine.
2	Changes in pressure and velocity	The pressure remains same(atmospheric) throughout the action of water on the runner	After entering the runner with an excess pressure, water undergoes changes both in velocity and pressure while passing through the runner.
3	Admittance of water over the wheel	Water may be allowed to enter a part or whole of the wheel circumference	Water is admitted over the circumference of the wheel
4	Installation of unit	Always installed above the tail race. No draft tube is used	Unit may be installed above or below the tail race. Use of draft tube is made.
5	Flow regulation	By means of needle valve	By means of guide vane assembly.

Turbine Efficiency

The head available for hydroelectric plant depends on the site conditions. Gross head is defined as the difference in level between the reservoir water level (called head race) and the level of water in the stream into which the water is let out (called tail race), both levels to be observed at the same time. During the conveyance of water there are losses involved. The difference between the gross head and head loss is called the net head or effective head. It can be measured by the difference in pressure between the turbine entry and tailrace level. The following efficiencies are generally used.

- (i) *Hydraulic efficiency*: It is defined as the ratio of the power produced by the turbine runner and the power supplied by the water at the turbine inlet.

$$\eta_H = \frac{\text{Power produced by the runner}}{\rho Q g H}$$

Where Q is the volume flow rate and H is the net or effective head. Power produced by the runner is calculated by the Euler turbine equation $P = Q\rho [u_1 V_{u1} - u_2 V_{u2}]$. This reflects the runner design effectiveness.

- (ii) *Volumetric efficiency*: It is possible some water flows out through the clearance between the runner and casing without passing through the runner. Volumetric efficiency is defined as the ratio between the volume of water flowing through the runner and the total volume of water supplied to the turbine. Indicating Q as the volume flow and ΔQ as the volume of water passing out without flowing through the runner. To some extent this depends on manufacturing tolerances.

$$\eta_v = \frac{Q - \Delta Q}{Q}$$

- (iii) *Mechanical efficiency*: The power produced by the runner is always greater than the power available at the turbine shaft. This is due to mechanical losses at the bearings and other frictional losses.

$$\eta_m = \frac{\text{Power available at the turbine shaft}}{\text{Power produced by the runner}}$$

- (iv) *Overall efficiency*: This is the ratio of power output at the shaft and power input by the water at the

turbine inlet.

$$\eta_o = \frac{\text{Power available at the turbine shaft}}{\rho Q g H}$$

In other way, the overall efficiency is the product of the all the three efficiencies and defined as

$$\eta_o = \eta_H \times \eta_v \times \eta_m$$

Pelton, Francis, Kaplan and Propeller Turbine

Pelton wheel

This is the only type used in high head power plants. This type of turbine was developed and patented by L.A. Pelton in 1889 and all the type of turbines is called by his name. A sectional view of a horizontal axis Pelton turbine is shown in figure 4. The main components are (1) Runner with the (vanes) buckets fixed on the periphery of the same (2) Nozzle assembly with control spear and deflector (3) Brake nozzle and (4) casing.

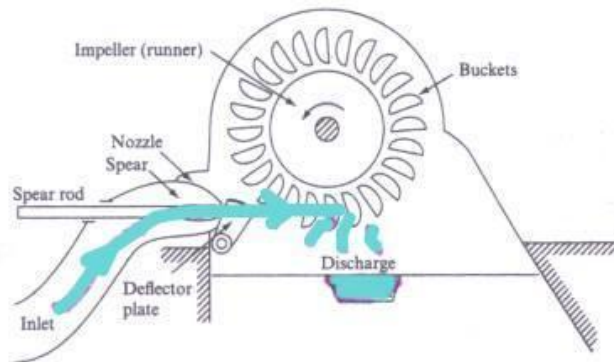

Figure 4 Pelton Wheel

The rotor or runner consists of a circular disc, fixed on suitable shaft, made of cast or forged steel. Buckets are fixed on the periphery of the disc. The spacing of the buckets is decided by the runner diameter and jet diameter and is generally more than 15 in number. These buckets in small sizes may be cast integral with the runner. In larger sizes it is bolted to the runner disc.

The buckets are also made of special materials and the surfaces are well polished. Originally spherical buckets were used and Pelton modified the buckets to the present shape. It is formed in the shape of two half ellipsoids with a splinter connecting the two. A cut is made in the lip to facilitate all the water in the jet to usefully impinge on the buckets. This avoids interference of the incoming bucket on the jet impinging on the previous bucket. Equations are available to calculate the number of buckets on a wheel. The number of buckets is Z and D is the runner diameter and d is the jet diameter.

$$Z = \left(\frac{D}{2d}\right) + 15$$

The nozzle and controlling spear and deflector assembly

The head is generally constant and the jet velocity is thus constant. A fixed ratio between the jet velocity and runner peripheral velocity is to be maintained for best efficiency. The nozzle is designed to satisfy the need. But the load on the turbine will often fluctuate and sometimes sudden changes in load can take place due to electrical circuit tripping. The velocity of the jet should not be changed to meet the load fluctuation due to frequency requirements. The quantity of water flow only should be changed to meet the load fluctuation. A

governor moves to and fro a suitably shaped spear placed inside the nozzle assembly in order to change the flow rate at the same time maintaining a compact circular jet.

When load drops suddenly, the water flow should not be stopped suddenly. Such a sudden action will cause a high pressure wave in the penstock pipes that may cause damage to the system. Meanwhile the spear will move at the safe rate and close the nozzle and stop the flow. The deflector will then move to the initial position. Even when the flow is cut off, it will take a long time for the runner to come to rest due to the high inertia. To avoid this braking jet is used which directs a jet in the opposite direction and stops the rotation. Some other methods like auxiliary waste nozzle and tilting nozzle are also used for speed regulation. The first wastes water and the second are mechanically complex. Inside the casing the pressure is atmospheric and hence no need to design the casing for pressure. It mainly serves the purpose of providing a cover and deflecting the water downwards. The casing is cast in two halves for ease of assembly. The casing also supports the bearing and as such should be sturdy enough to take up the load.

When the condition is such that the specific speed indicates more than one jet, a vertical shaft system will be adopted. In this case the shaft is vertical and a horizontal nozzle ring with several nozzles is used. The jets in this case should not interfere with each other.

Generally the turbine directly drives the generator. The speed of the turbine is governed by the frequency of AC Power used in the region. The product of the pairs of poles used in the generator and the speed in rps gives the number of cycles per second. Steam turbines operate at 3000 rpm or 50 rps in the areas where the AC frequency is 50 cycles per second. Hydraulic turbines handle heavier fluid and hence cannot run at such speeds. In many cases the speed is in the range to 500 rpm. As the water flows out on both sides equally axial thrust is minimal and heavy thrust bearing is not required.

Francis Turbine

Francis turbine is a radial inward flow turbine and is the most popularly used one in the medium head range of 60 to 300 m. Francis turbine was first developed as a purely radial flow turbine by James B. Francis, an American engineer in 1849. But the design has gradually changed into a mixed flow turbine of today. A sectional view of a typical Francis turbine of today is shown in figure 5. The main components are (i) The spiral casing (ii) Guide vanes (iii) Runner (iv) Draft tube and (v) Governor mechanism. Most of the machines are of vertical shaft arrangement while some smaller units are of horizontal shaft type.

Spiral Casing

The spiral casing surrounds the runner completely. Its area of cross section decreases gradually around the circumference. This leads to uniform distribution of water all along the circumference of the runner. Water from the penstock pipes enters the spiral casing and is distributed uniformly to the guide blades placed on the periphery of a circle. The casing should be strong enough to withstand the high pressure.

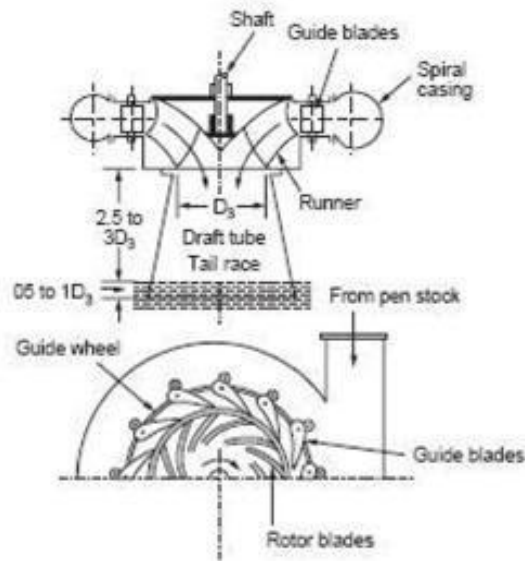

Figure 5 Typical sectional and front view of a modern Francis turbine

Guide Blades

Water enters the runner through the guide blades along the circumference. The number of guide blades is generally fewer than the number of blades in the runner. These should also be not simple multiples of the runner blades. The guide blades in addition to guiding the water at the proper direction serve two important functions. The water entering the guide blades are imparted a tangential velocity by the drop in pressure in the passage of the water through the blades. The blade passages act as a nozzle in this aspect.

The guide blades rest on pivoted on a ring and can be rotated by the rotation of the ring, whose movement is controlled by the governor. In this way the area of blade passage is changed to vary the flow rate of water according to the load so that the speed can be maintained constant. The variation of area between guide blades is illustrated in Figure 6.

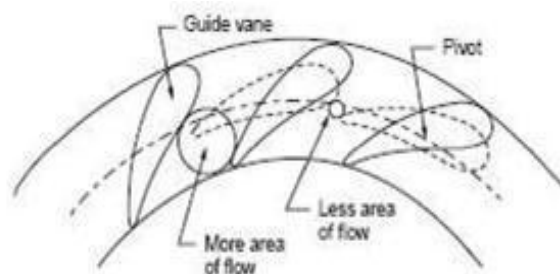

Figure 6 Guide vane and guide wheel

The Runner

The runner is circular disc and has the blades fixed on one side. In high speed runners in which the blades are longer a circular band may be used around the blades to keep them in position.

The shape of the runner depends on the specific speed of the unit. These are classified as (a) slow runner (b) medium speed runner (c) high speed runner and (d) very high speed runner. The shape of the runner and the

corresponding velocity triangles are shown in figure 7. The development of mixed flow runners was necessitated by the limited power capacity of the purely radial flow runner. A larger exit flow area is made possible by the change of shape from radial to axial flow shape. This reduces the outlet velocity and thus increases efficiency. As seen in the figure the velocity triangles are of different shape for different runners. It is seen from the velocity triangles that the blade inlet angle β_1 changes from acute to obtuse as the speed increases. The guide vane outlet angle α_1 also increases from about 15° to higher values as speed increases.

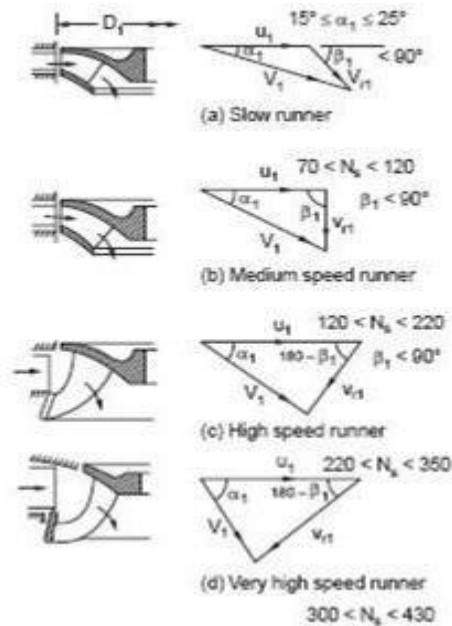

Figure 7 Variation of runner shapes and inlet velocity triangles with specific speed

In all cases, the outlet angle of the blades are so designed that there is no whirl component of velocity at exit ($V_{u2} = 0$) or absolute velocity at exit is minimum. The runner blades are of doubly curved and are complex in shape. These may be made separately using suitable dies and then welded to the rotor. The height of the runner along the axial direction (may be called width also) depends upon the flow rate which depends on the head and power which are related to specific speed. As specific speed increases the width also increase accordingly. Two such shapes are shown in figure 8. The runners change the direction and magnitude of the fluid velocity and in this process absorbs the momentum from the fluid.

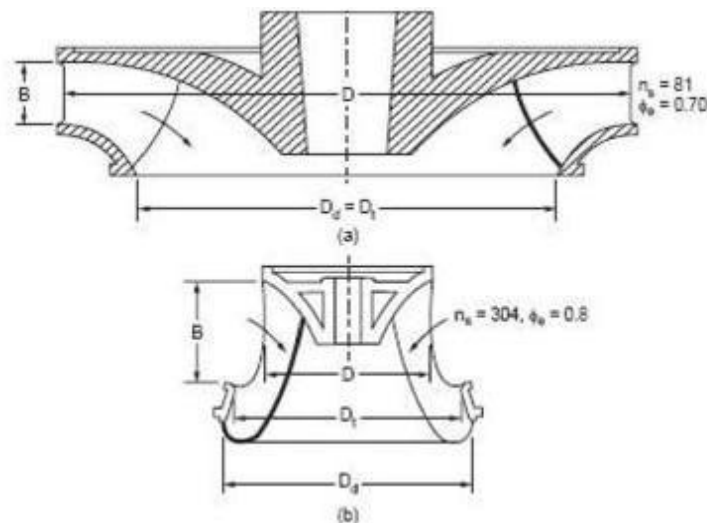

Figure 8 Slow speed and high speed runner shapes

Draft Tube

The turbines have to be installed a few meters above the flood water level to avoid inundation. In the case of impulse turbines this does not lead to significant loss of head. In the case of reaction turbines, the loss due to the installation at a higher level from the tailrace will be significant. This loss is reduced by connecting a fully flowing diverging tube from the turbine outlet to be immersed in the tailrace at the tube outlet. This reduces the pressure loss as the pressure at the turbine outlet will be below atmospheric due to the arrangement. The loss in effective head is reduced by this arrangement. Also because of the diverging section of the tube the kinetic energy is converted to pressure energy which adds to the effective head. The draft tube thus helps (1) to regain the lost static head due to higher level installation of the turbine and (2) helps to recover part of the kinetic energy that otherwise may be lost at the turbine outlet. A draft tube arrangement is shown in Figure. Different shapes of draft tubes are shown in figure 9.

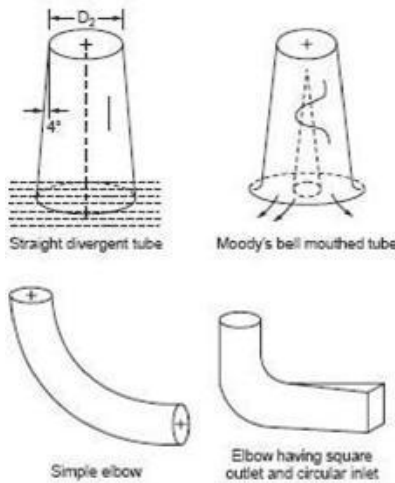

Figure 9 Various shapes of draft tubes

The head recovered by the draft tube will equal the sum of the height of the turbine exit above the tail water level and the difference between the kinetic head at the inlet and outlet of the tube less frictional loss in head.

$$H_d = H + \frac{V_1^2 - V_2^2}{2g} - h_f$$

Where H_d is the gain in head, H is the height of turbine outlet above tail water level and h_f is the frictional loss of head.

Different types of draft tubes are used as the location demands. These are (i) *straight diverging tube* (ii) *Bell mouthed tube* and (iii) *Elbow shaped tubes of circular exit or rectangular exit*. Elbow types are used when the height of the turbine outlet from tailrace is small. Bell mouthed type gives better recovery. The divergence angle in the tubes should be less than 10° to reduce separation loss. The height of the draft tube will be decided on the basis of cavitation. The efficiency of the draft tube in terms of recovery of the kinetic energy is defined as

$$\eta = \frac{V_1^2 - V_2^2}{V_1^2}$$

Where V_1 is the velocity at tube inlet and V_2 is the velocity at tube outlet.

Kaplan Turbine

The Propeller turbine is suitable when the load on turbine remains constant. It has low efficiency at part load, as blade angles do not change and water enters with shock accompanied with losses. The Kaplan turbine is fitted with adjustable runner blades and both guide vanes and runner blades act simultaneously. The blade angles change automatically by servo motor as load changes. Thus Kaplan has high efficiency at part loads. Kaplan turbine installation with draft tube is shown in Figure 10.

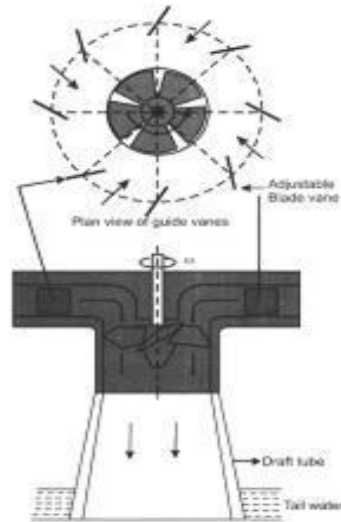

Figure 10 Kaplan turbine with draft tube

Propeller Turbine

The need to utilize low heads where large volume of water is available makes it essential to provide a large flow area and to run the machine at very low speeds. The propeller turbine is a reaction turbine used for heads between 4 m to 80 m. It is purely axial-flow device providing the largest possible flow area that will utilize a large volume of water and still obtain flow velocities which are not too large. The propeller turbine consists of an axial flow runner with four to six or at the most ten blades of air foil shape. The runner is generally kept horizontal i.e. the shaft is vertical. The blades resemble the propeller of a ship. In the propeller turbine, as in Francis turbine, the runner blades are fixed and non-adjustable. The spiral casing and guide blades are similar to those in Francis turbine. The guide mechanism is similar to that in a Francis turbine.

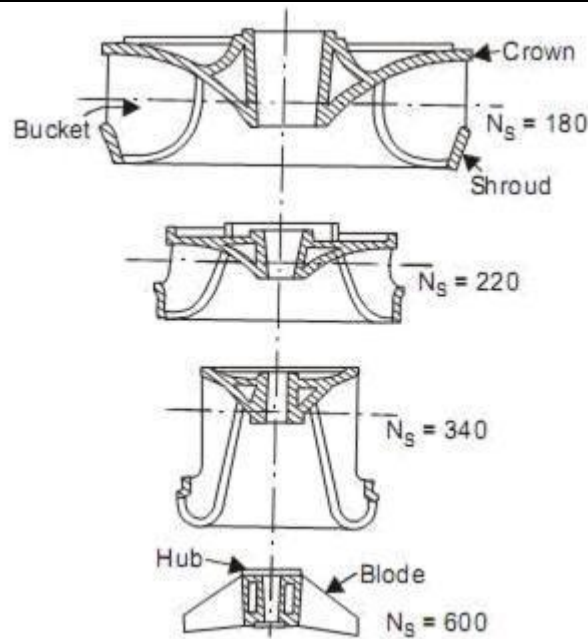

Figure 11 Propeller Turbine

Impulse Turbines

In impulse type turbine, the pressure energy of the water is converted into kinetic energy when passed through the nozzle and forms the high velocity jet of water. The formed water jet is used for driving the wheel. The casing of the impulse turbine operates at atmospheric pressure whereas the casing of the reaction turbine operates under high pressure. The pressure acts on the rotor and vacuum underneath it. This is why the casing of reaction turbine is made completely leak proof.

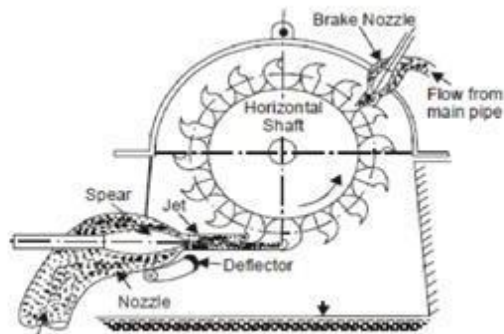

Figure 12 Impulse Turbines

Figure 12 above shows the layout of the Pelton turbine. This was discovered by Pelton in 1880. This is a special type of axial flow impulse turbine generally mounted on horizontal shaft, as mentioned earlier a number of buckets are mounted round the periphery of the wheel as shown in Fig above. The water is directed towards the wheel through a nozzle or nozzles. The flow of water through the nozzle is generally controlled by special regulating system. The water jet after impinging on the buckets is deflected through an angle of 160° and flows axially in both directions thus avoiding the axial thrust on the wheel. The hydraulic efficiency of Pelton wheel lies between 85 to 95%. Now-a-days, Pelton wheels are used for very high heads upto 2000 meters.

Arrangement of jets

In most of the Pelton wheel plants, single jet with horizontal shaft is used. The number of the jets adopted depends upon the specific speed required. Any impulse turbine achieves its maximum efficiency when the velocity of the bucket at the center line of the jet is slightly under half the jet velocity. Hence, for maximum speed of rotation, the mean diameter of the runner should be as small as possible. There is a limit to the size of the jet which can be applied to any impulse turbine runner without seriously reducing the efficiency. In early twenties, a normal ratio of D/d was about 10: 1. In a modern Turbo impulse turbine, it is reduced upto 4.5 to 1. The basic advantage of Turbo impulse turbine is that a much larger jet could be applied to a runner of a given mean diameter. The jet of Pelton turbine strikes the splitter edge of the bucket, bifurcates and is discharged at either side. With the turbo impulse turbine, the jet is set at an angle to face the runner, strikes the buckets at the front and discharges at opposite side. The basic difference between the two is shown in Fig 13.

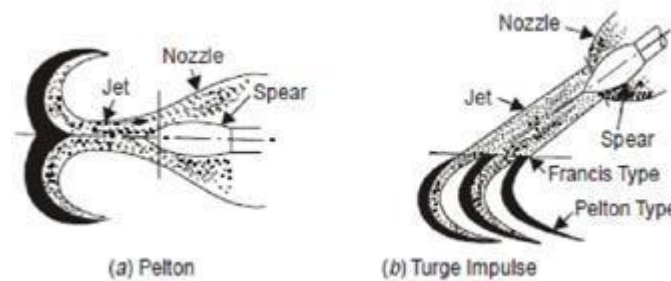

Figure 13 Jets of Impulse Turbines

Reaction Turbines

The functioning of reaction turbines differs from impulse turbines in two aspects.

- In the impulse turbine the potential energy available is completely converted to kinetic energy by the nozzles before the water enters the runner. The pressure in the runner is constant at atmospheric level. In the case of reaction turbine the potential energy is partly converted to kinetic energy in the stator guide blades. The remaining potential energy is gradually converted to kinetic energy and absorbed by the runner. The pressure inside the runner varies along the flow.
- In the impulse turbine only a few buckets are engaged by the jet at a time.

In the reaction turbine as it is fully flowing all blades or vanes are engaged by water at all the time. The other differences are that reaction turbines are well suited for low and medium heads (300 m to below) while impulse turbines are well suited for high heads above this value. Also due to the drop in pressure in the vane passages in the reaction turbine the relative velocity at outlet is higher compared to the value at inlet. In the case of impulse turbine there is no drop in pressure in the bucket passage and the relative velocity either decreases due to surface friction or remains constant. In the case of reaction turbine the flow area between two blades changes gradually to accommodate the change in static pressure. In the case of impulse turbine the speed ratio for best efficiency is fixed as about 0.46. As there is no such limitation, reaction turbines can be run at higher speeds.

Selection of turbines

The major problem confronting the engineering is to select the type of turbine which will give maximum economy. The hydraulic prime-mover is always selected to match the specific conditions under which it has to operate and attain maximum possible efficiency. The choice of a suitable hydraulic prime-mover depends upon various considerations for the given head and discharge at a particular site of the power plant. The type of the turbine can be determined if the head available, power to be developed and speed at which it has to run are known to the engineer beforehand. The following factors have the bearing on the selection of the right type of hydraulic turbine which will be discussed separately.

- Rotational Speed
- Specific Speed
- Maximum Efficiency
- Part Load Efficiency
- Head
- Type of Water
- Runaway Speed
- Cavitations
- Number of Units
- Overall Cost

Rotational speed

In all modern hydraulic power plants, the turbines are directly coupled to the generator to reduce the transmission losses. This arrangement of coupling narrows down the range of the speed to be used for the prime-mover. The generator generates the power at constant voltage and frequency and, therefore, the generator has to operate at its synchronous speed. The synchronous speed (N_{sysn}) of a generator is given by

$$N_{sysn} = \frac{60 \times f}{p}$$

Where f = Frequency and p = Number of pairs of poles used. For the direct coupled turbines, the turbine has to run at synchronous speed only. There is less flexibility in the value of N_{sysn} as f is more or less fixed (50 or 60 cycles/sec). It is always preferable to use high synchronous speed for generator because the number of the poles required would be reduced with an increase in N_{sysn} and the generator size gets reduced. Therefore, the value of the specific speed adopted for the turbine should be such that it will give synchronous speed of the generator. The problems associated with the high speed turbines are the danger of cavitations and centrifugal forces acting on the turbine parts which require robust construction. No doubt, the overall cost of the plant will be reduced adopting higher rotational speed as smaller turbine and smaller generator are required to generate the same power. The constructional cost of the power house is also reduced.

Specific speed

The equation indicates that a low specific speed machine such as impulse turbine is required when the available head is high for the given speed and power output. On the other hand, propeller turbines with high specific speed are required for low-heads. The specific speed can be calculated using the equations and if the available head is known. The specific speed versus head is shown in figure for different turbines. It is obvious from figure that there is considerable latitude in the specific speed of runners which can be used for given conditions of head and power provided that the height of the runner above tailrace level is such as to avoid the danger of cavitation as discussed earlier.

In all modern power plants, it is common practice to select a high specific speed runner because it is more

economical as the size of the turbo-generator as well as that of power house will be smaller. High specific speed is essential when the available head is low and power output is high because otherwise the rotational speed will be very low and it will increase the cost of turbo-generator and the power house as the sizes of turbine, generator and power house required at low speed will be large. On the other hand, there is no need of choosing high specific speed runner when the available head is sufficiently large because even with low specific speed, high rotational speeds can be attained. Now it has been shown with the above discussion that if the speed and power under a given head are fixed (N_s is fixed), the type of the runner required is also fixed.

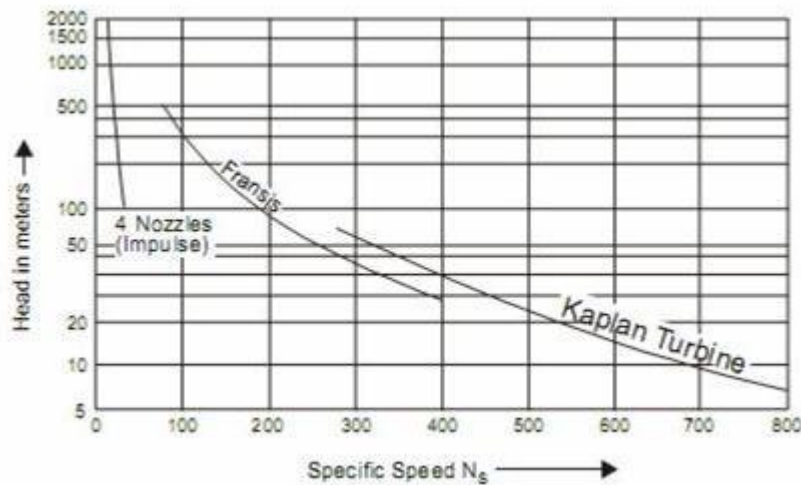

Figure 14 Specific speed versus head

In practice it may be possible to vary the specific speed through a considerable range of values. The speed and power required may be varied for a single runner and the choice is made wider. Suppose turbine of a given power runs at 120 r.p.m. or at 900 r.p.m. and say available head is 200 meters, if the power is developed in a single unit at 120 r.p.m. is 18000 H.P. the required specific speed of the runner is given by

$$N_s = \frac{120\sqrt{18000}}{(200)^{\frac{5}{4}}} = 30.4$$

Now if the same power is developed at 900 r.p.m. in two runners, the required specific speed of the runner is given by

$$N_s = \frac{900\sqrt{18000}}{(200)^{\frac{5}{4}}} = 161$$

The above calculations show that the required power can be developed either with one impulse turbine (Pelton) or two reaction turbines (Francis). It is customary to choose a speed between certain limits, as neither a very low nor a very high r.p.m. is desirable. The number of units into which a given power is divided is also limited. Nevertheless considerable latitude is left concerning the choice of the prime-mover and number of units used. Ultimately the choice of prime-mover is a matter of extensive experience instead of paper calculation.

Maximum Efficiency

The maximum efficiency, the turbine can develop, depends upon the type of the runner used. In case of impulse turbine, low specific speed is not conducive to efficiency, since the diameter of the wheel becomes relatively large in proportion to the power developed so that the bearing friction and windage losses tend to become too large in percentage value. The value of N_s for highest efficiency is nearly 20. The low specific speed of reaction turbine is also not conducive to efficiency. The large dimensions of the wheel at low specific speed contribute disc friction losses. In addition to this, the leakage loss is more as the leakage area

through the clearance spaces becomes greater and the hydraulic friction through small bracket passages is larger. These factors tend to reduce the efficiency as small values of specific speed are approached.

The high specific speed reaction turbines are associated with large discharge losses as mentioned earlier. The friction and leakage losses are reduced with an increase in specific speed but the discharge losses increase rapidly and the net effect of increase in specific speed is to decrease the efficiency total loss (friction, leakage and discharge) is minimum at medium specific speed. Therefore, it is always preferable to select the reaction turbines of medium specific speed if they operate at constant load conditions. The effect of specific speed on the maximum efficiency is shown in figure 15.

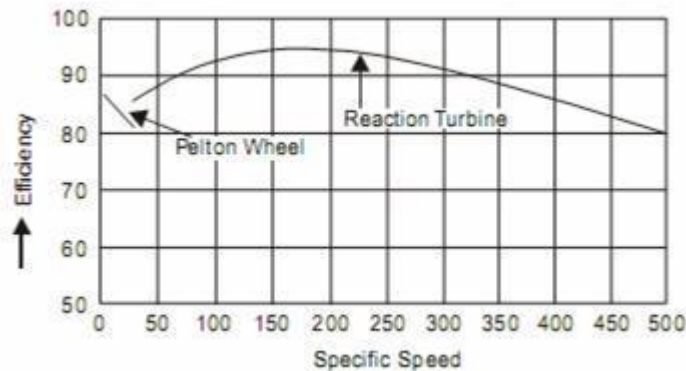

Figure 15 Effect of specific speed on efficiency

Higher efficiencies have been attained with reaction turbines than with Pelton wheels. The maximum *recorded* efficiency till now for reaction turbine is 93.7% but quite a large unit has shown efficiencies over 90% the highest recorded value of efficiency for impulse Turbine is 89% but usual maximum is 82%. The efficiency of the Pelton wheel is not dependent on its size like reaction turbine. Hence the Pelton wheel may have higher maximum efficiency than the reaction turbine for smaller powers.

Part Load Efficiency

Full load is defined as the load under which a turbine develops its maximum efficiency anything above that is known as overload and anything below that is known as part load. The part load efficiency differs greatly for different specific speed and types of turbines. Figure shows the variations in part load efficiencies with different types of wheels. In case of Pelton wheel, only the jet diameter through which the water flows is reduced by the governing *mechanism* when the load on the turbine is reduced below full load. The velocity diagrams at inlet and outlet remain practically unaltered in shape at all loads except for very low and very high loads. Thus the absolute velocity at inlet does not change and discharge loss remains same. Therefore, the part load efficiency curve is more flat in case of Pelton turbine.

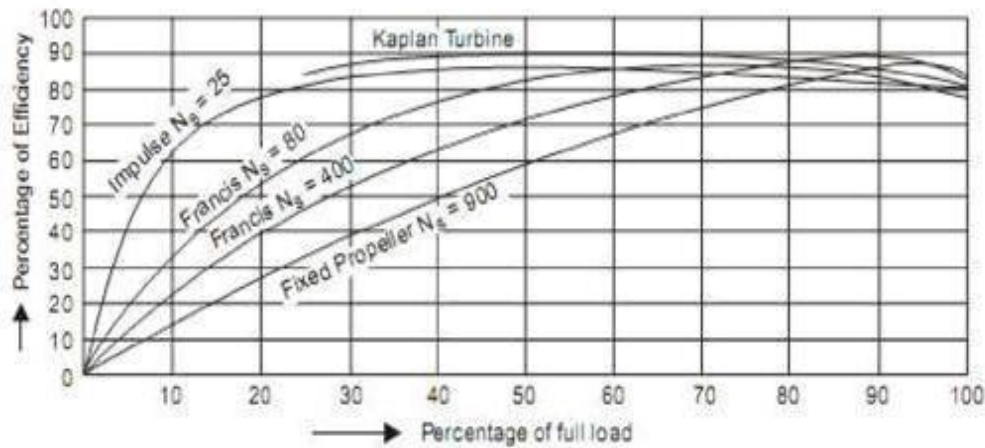

Figure 16 Variations in part load efficiencies

7.3 SPILLWAY, SURGE CHAMBERS, PENSTOCK, TAILRACE

Spillways

When the water enters the reservoir basin, the level of water in basin rises. This rise is arranged to be of temporary nature because excess accumulation of water endangers the stability of dam structure. To relieve reservoir of this excess water contribution, a structure is provided in the body of a dam or near the dam or on the periphery of a basin. This safeguarding structure is called a spillway. A spillway should fulfill the following requirements:

- It should provide structural stability to the dam under all conditions of floods.
- It should be able to pass the designed flood without raising reservoir level above high flood level (H.F.L).
- It should have an efficient operation.
- It should have an economical section.

Types of Spillways

Following are some types of spillways

- Overfall spillway or solid gravity spillway
- Chute or trough spillway
- Side channel spillway

- Saddle spillway
- Emergency spillway
- Shaft or glory hole spillway
- Siphon spillway

Overfall spillway or solid gravity spillway

This type of spillway is provided in case of concrete and masonry dams. It is situated in the body of the dam, generally in the centre. As it is provided in the dam itself the length of dam should be sufficient to accommodate the designed spillway crest. This spillway consists of an ogee crest and a bucket. Water spills and flows over the crest in the form of a rolling sheet of water. The bucket provided at the lower end of the

spillway changes the direction of the fast moving water. In this process the excess energy of fast moving water is destroyed. The portion between the front vertical face and the lower nappe of sheet of water is filled with concrete to conform the profile of the spillway to the lower nappe.

Chute or trough spillway

This type of spillway is most suited under the situation when the valley is too narrow to accommodate the solid gravity spillway in the body of the dam or when the non-rigid type of dam is adopted. It is called chute spillway because after crossing over the crest of the spillway the water flow shoots down a channel or a trough to meet the river channel downstream of the dam. In this type the crest of the spillway is at right angles to the centre line of the trough or the chute. The crest is isolated from the dam axis. The trough is taken straight from the crest to the river and it is generally lined with concrete.

Side channel spillway

A side channel spillway is employed when the valley is too narrow in case of a solid gravity dams and when non-rigid dams are adopted. In non-rigid dams it is undesirable to pass the flood water over the dam. When there is no room for the provision of chute spillway this type is adopted as it requires comparatively limited space. Thus the situations where chute and side channel spillways are mostly the same. The side channel spillways differs from the chute spillway in the sense that after crossing over the spillway crest, water flows parallel to the crest length in former, whereas the flow is normal to the crest in the latter.

Saddle spillway

A saddle spillway may be constructed when conditions are not favourable for any of the types mentioned above. There may be some natural depression or saddle on the periphery of the reservoir basin away from the dam. The depression may be used as a spillway. It is essential that the bottom of the depression should be at full reservoir level.

Emergency spillway

As the name suggests this type of spillway is very rarely put into action. Naturally it is not necessary to protect the structure, its foundation or its discharge channel from serious damage.

Shaft or glory hole spillway

The shape of shaft spillway is just like a funnel. The lower end of the funnel is turned at right angles and then taken out below the dam horizontally. Water spills over the crest, which is circular, and then enters the vertical shaft and is taken out below the dam through a horizontal tunnel. Sometimes the flow is guided by means of radial piers on the crest of the spillway. It avoids creation of spiral flow in the shaft. The piers may be used to support a bridge around the crest. The bridge may be used to connect the spillway to the dam.

Siphon spillway

A siphon spillway, as the name suggests, is designed on the principle of a siphon.

Surge Chambers

A surge chamber or surge tank is a small reservoir or tank in which the water level rises or falls to reduce the pressure swings so that they are not transmitted in full to a closed circuit. In general a surge tank serves the following purposes:

- To reduce the distance between the free water surface and turbine thereby reducing the water-hammer effect on penstock and also protect upstream tunnel from high pressure rises.

- To serve as a supply tank to the turbine when the water in the pipe is accelerating during increased load conditions and as a storage tank when the water is decelerating during reduced load conditions.

Types of surge tanks

The different types of surge tanks in use are:

- Simple surge tank
- Inclined surge tank
- The expansion chamber and gallery type surge tank
- Restricted orifice surge tank
- Differential surge tank

Simple surge tank

A simple surge tank is a vertical stand pipe connected to the penstock. In the surge tank if the overflow is allowed, the rise in pressure can be eliminated but overflow surge tank is seldom satisfactory and usually uneconomical. Surge tanks are built high enough so that water cannot overflow even with a full load change on the turbine. It is always desirable to place the surge tank on ground surface, above the penstock line, at the point where the latter drops rapidly to the power house. Under the circumstances when suitable site for its location is not available the height of the tank should be increased with the help of a support.

Inclined surge tank

When a surge tank is inclined to the horizontal its effective water surface increases and therefore, lesser height surge tank is required of the same diameter if it is inclined or lesser diameter tank is required for the same height. But this type of surge tank is more costlier than ordinary type as construction is difficult and is rarely used unless the topographical conditions are in favour.

Expansion chamber surge tank

This type of a surge tank has an expansion tank at top and expansion gallery at the bottom; these expansions limit the extreme surges. The upper expansion chamber must be above the maximum reservoir level and bottom gallery must be below the lowest steady running level in the surge tank. Besides this the intermediate shaft should have a stable minimum diameter.

Restricted orifice surge tank

It is also called throttled surge tank. The main object of providing a throttle or restricted orifice is to create an appreciable friction loss when the water is flowing to or from the tank. When the load on the turbine is reduced, the surplus water passes through the throttle and a retarding head equal to the loss due to throttle is built up in the conduit. The size of the throttle can be designed for any designed retarding head. The size of the throttle adopted is usually such as the initial retarding head is equal to the rise of water surface in the tank when the full load is rejected by the turbine.

Differential Surge tank

A differential surge tank has a riser with a small hole at its lower end through which water enters in it. The function of the surge tank depends upon the area of hole.

Penstock

It is a closed conduit for supplying water under pressure to a turbine.

Advantages and limitations of different types of conduits:

- Open channels are generally the least expensive, but the cost of a flume increases with the height of the trestle.
- Tunnels are generally the most costly type of conduit for a given length but are justified if their use results in considerable saving in distance. While ordinarily tailraces are open channels, tunnels are used for the discharge from an underground hydro-station.
- Penstocks are used where the slope is too great for a canal, especially for the final stretch of the diversion system where the land pitches steeply to the powerhouse.

Tailrace

The tailrace is the downstream part of a dam where the impounded water re-enters the river.

7.4 TYPES OF GENERATORS - SYNCHRONOUS AND INDUCTION, TRANSFORMERS, PROTECTION & CONTROL, TRANSMISSION AND DISTRIBUTION SYSTEM

Generators

The generators employed in hydro-plant are usually 3-phase synchronous machines and have either a vertical shaft arrangement or horizontal shaft arrangement; but vertical shaft arrangement is preferred. Three-phase AC generators are used for the distribution, transmission and generation of large-scale hydroelectric power. The power output of a 3-phase alternator is given by

$$P = \sqrt{3} \times V \times I \times \cos\phi$$

P= Power output

V= Voltage (in Volts)

I= Current (in amperes)

CosΦ = Power factor (Varies from 0.9 to 0.95)

Synchronous Generators

It is commonly used to convert the mechanical power output of steam turbine, gas turbine, hydro turbines into electrical power for the grid. Synchronous generators are known as synchronous machines because they operate at synchronous speed. There are two types of Synchronous generator

- Stationary field
- Revolving field

In stationary field synchronous generator, poles on the stator (field winding) are supplied with DC to create a stationary magnetic field. Armature winding on rotor consists of a 3-phase winding whose terminals connect to 3 slip-rings on the shaft. This arrangement works for low power machines (<5kVA). Revolving field synchronous generator has stationary armature with 3-phase winding on stator. It is most commonly known as alternator.

Induction generator

An induction generator is AC electrical generator. Principles of induction motors are used by induction generator to produce power. Induction generators operate by mechanically turning their rotor in generator mode, giving negative slip. In most cases, a regular AC asynchronous motor is used as a generator, without any internal modifications.

Transformers

These may be of single phase or three phase type. They are oil filled for insulation and cooling purposes. The generated voltage is stepped up by means of step up transformers. Transformers may be of power or distribution type.

Hydro- Plant Controls

The various controls which are provided in a hydro- electric power plant are listed and discussed below:

- Hydraulic controls
- Machine controls- starting and stopping
- Machine controls- loading and frequency
- Voltage control of generator and system
- Machine protection

Hydraulic controls

In a hydro- plant the following hydraulic controls are provided:

- Storage level indicators- primary and secondary
- Flood control
- River flow control
- Intake gate control

Machine controls- starting and stopping

The control of water flowing to the turbine is exercised by providing gates and valves in the supplying conduit and at the turbine inlet. The quantity of water flowing to the turbine is regulated according to the load on the generator by the use of a governor system. While starting the turbines the casing should be filled gradually and to limit the rate of water flow by pass valves are provided.

Machine controls- loading and frequency

The load on the machine is controlled as follows:

- By adjusting the governor speed control
- By controlling system frequency

Voltage control of generator and system

The voltage regulators are employed to ensure that electric power is supplied at proper voltage.

Machine protection

In a hydro plant provision of protective devices should be made to guard against breakdown of turbo-generator and auxiliary services, like transformers, switchgears, overhead lines etc. Protection measures are also required to guard against incorrect operation and failure of control system. Automatic controls are efficient, safe and reliable. The control room should be designed for convenience of operation and the equipment should be so arranged/ spaced that it is easily accessible.

Transmission of Electric Power

Systems of Transmission

For transmission of electrical power three phase circuits are generally used because of economical reasons.

Transmission lines may be classified as follows:

- Single line
- Parallel lines
- Radial lines
- Ring system
- Network

Single line

The simplest form is the single line, such as obtained from a power plant supplying its entire output to one load centre over a single circuit line.

Parallel lines

Where continuity of service is necessary, it is best to use at least two circuits in parallel, placed either on the same supports or on separate supports.

Radial lines

Invariably a power plant or substation supplies power to the neighboring territory by means of radial lines.

Ring system

For systems covering a large territory the ring system of transmission is very important. With this system the main high voltage power line makes a closed ring, taps being taken off at any advantageous point of the ring, thus supplying a large territory.

Network

A network often constitutes several ring systems with sections of single, parallel or radial lines.

Line supports

Electrical power may be transmitted by overhead or underground conductors. Underground transmission with the exception of a few notable cases, is limited to voltage less than 45,000 volts. The supports for the overhead transmission lines may be of any one of the following classes: (i) Poles (ii) Towers

Conductor Material

Electric power conductors are generally of the following materials: copper, aluminum and steel or some combination of these three metals. In some cases special alloys have been used.

Line Insulators

The insulators of a transmission line are its most important item since the operation of a line cannot be any better than the insulators that support the conductors. Transmission line insulators must possess good mechanical strength and good insulating qualities under all conditions of weather and temperature and must not deteriorate fast. Insulators are made of glass, porcelain, and patented compounds. Transmission line insulators may be classified as follows:

- Pin type
- Suspension type
- Strain type

For low voltages, pin type insulators made of glass are generally used. For voltages above 66,000 volts it is

generally desirable to use suspension insulators. Strain insulators may be pin or suspension type. Upto about 30,000 volts pin type insulators are satisfactory, but for higher voltages the suspension type is generally used.

Distribution systems

Distribution systems comprise that part of the network of a power system which distributes power for local use. Distribution system may be classified as follows

- Nature of current
 - Direct current
 - Two wire
 - Three wire
 - Alternating current
- Methods of connection
 - Series
 - Open loop
 - Parallel loop
 - Combination of open and parallel loops
 - Multiple
 - Three system
 - Feeder and main
 - Network
 - Loop system
 - Ring system
- Number of phases
 - Single
 - Two wire
 - Three wire
 - Two
 - Three wire
 - Four wire
 - Five wire
 - Three
 - Three wire
 - Four wire
- Mounting
 - Overhead
 - Underground
- Voltage
 - 115/230,
 - 550
 - 1100
 - 2200
 - 6600
 - 11000
 - 12000
 - 13200
 - 32000 V

Underground Cables

Underground cables consist of one or more conductors properly insulated, all surrounded by a lead sheath which excludes air and moisture and also acts as a protecting cover. Cables for underground service may be

classified as follows:

- Number of conductors
 - (i) Single conductor (ii) Multi-conductor
- Arrangement of conductors
 - (i) Single (ii) Sector (iii) Concentric
- Number of
phases
 - (i) Single phase (ii) Polyphase
- Type of insulation
 - (i) Rubber (ii) Varnished cambric (iii) Oiled paper (iv) Graded (v) Oil filled
- Special features, split conductor
 - (i) Concentric (ii) D- shaped

Suggested Reading References

5. P K Nag, Power Plant Engineering, 3rd Edition, Tata McGraw Hill, 2008
6. Wagner H. Mathur J. Introduction to Hydro Energy systems: Basic, Technology and Operations, Springer, 2011

DRE 104: WIND AND HYDRO ENERGY

UNIT-8: HYDROPOWER PLANT DEVELOPMENT

UNIT STRUCTRE

INTRODUCTION

- 8.1 SITE SELECTION, RUN-OF-THE RIVER AND STORAGE SCHEMES
 - 8.1.1 DIVERSION STRUCTURE
 - 8.1.2 POWER CHANNELS
 - 8.1.3 DE-SILTING ARRANGEMENTS
 - 8.1.4 FOREBAY TANK
- 8.2 ECONOMICS: COST STRUCTURE, INITIAL AND OPERATION COST
 - 8.2.1 ENVIRONMENTAL ISSUES RELATED TO SMALL AND LARGE HYDROPOWER
- 8.3 POTENTIAL OF HYDRO POWER IN NORTH EAST INDIA PLANTS

INTRODUCTION

It is expected that during the next few decades, there will be a multi fold increase in hydro power generation worldwide. On one hand, large power plants such as Three Gorges Dam, China and Itaipu, Brazil have set new standards while offering advantages of low electricity generation cost together with offering economic benefits related to irrigation, flood control, tourism, fishery and other developmental activities. On the other side, micro hydro power plants are also turning out to be extremely useful in remote locations of developing and underdeveloped countries. Technological advancements related to the design and operation of power plants is improving the reliability and availability of power plants.

8.1 SITE SELECTION, RUN-OF-THE RIVER AND STORAGE SCHEMES

8.1.1 DIVERSION STRUCTURE

Diversion structure raises the water level of the river slightly, not for creating storage, but for allowing the water to get diverted through a canal situated at one or either of its banks. Since a diversion structure does not have enough storage, it is called a run-of-the river scheme. The diverted water passed through the canal may be used for irrigation, industry, domestic water needs or power generation.

The mountainous and sub-mountainous regions are suitable for locating a diversion structure for hydroelectric power schemes due to the availability of high heads and less siltation problems. However, there could be problems at the head works (intake) of the canal due to possible withdrawal of shingles and arrangements have to be made for the

elimination of these. For irrigation canals taking off from the head-works, the service area (where the water would actually be used for irrigation) will start after some distance from the head-works and the idle length of the canal would be more. Further, there would be more number of drainages (hilly streams and torrents) that has to be crossed by the canal as compared to the one in the plains. It is also natural for the canal in the mountainous and sub-mountainous regions to negotiate terrain with relatively larger changes in elevation than the canals passing through alluvial or deltaic stretches of rivers. For power channels the difference in elevations can be effectively utilized by generating hydro-power. In case of irrigation canals, a large number of drops have to be provided. Of course, many irrigation canal drops have been combined with a hydro-electric power generating unit.

8.1.2 POWER CHANNELS

A power channel (canal) called the open-channel is sometimes required to connect a reservoir with a power intake when the geology or topography is not suitable for a tunnel or when an open-channel is more economical. The channel can be lined or unlined, depending on the suitability of the foundation material and the projects economics. Friction factors for various linings used for design are as follows:

Lining	Minimum	Maximum
Unlined rock	0.030	0.035
Shotcrete	0.025	0.030
Formed concrete	0.012	0.016
Grassed earth	0.030	0.100

Balancing reservoir

A water reservoir is an enclosed area for the storage of water to be used at a later date; it can also serve to catch floods to protect valleys downstream of it; to establish an aquatic environment; or to change the properties of the water. A reservoir can be created by building a dam across a valley, or by using natural or manmade depressions. The main parameters of the reservoir are the volume, the area inundated and the range that the water level can fluctuate. In the balancing reservoir of a peak load hydro power plant the inflow is given indirectly by the load of the plant. A balancing reservoir downstream of a peak load hydro power plant sometimes also serves to pump water to a main reservoir or to a special storage reservoir.

8.1.3 DE-SILTING ARRANGEMENTS

The silting of power reservoir has economic repercussion due to the reduction of active storage with passage of time. The present worth of all dams is said to be over \$ 600 billion and the associated reservoirs are estimated to be losing storage capacity at an average annual rate of about 1% due to insidious encroachment by sediment. Generally in India, the reservoirs are designed for a life of over 100 years. However, varying siltation rates in different catchments can have influence over the estimated life. In general, the siltation rates are working out to be 0.1 to 0.2 ha m/yr/km². In modern times frequent satellite remote sensing based surveys can be complementary to the conventional Hydrographic surveys at longer intervals. Rational management of reservoir operation requires silt- consciousness to maximize the useable water volume and to release maximum sediment through cyclic hydraulic flushing and sluicing.

The removal of sediments from a reservoir may be accomplished by excavation, dredging, drainage and flushing and

sluicing. The disposal of removed sediment must be planned so that the disposed material does not return to the reservoir or the main stream. If the silt gets transported through the stream further down and gets deposited towards the sea thereby gradually flattening the slope of the river in its lower reaches, it would tend to diminish the flood discharging capacity of the river. Experience shows that the sediment can often be used effectively either for the replenishment of agricultural land or as aggregate and construction material.

Dimension of silt in the Indian context

Indian rivers carry huge sediment during monsoon. In the Himalayan region, sediment gets multiplied due to

- (a) the young geology, immature, soft and loose
 - (b) Glacial silt in snow melt season
-
- as high as 80,000 ppm concentration leads to accumulation of millions of tones of silt in reservoirs
 - despite elaborate de-silting arrangements, silt passes through the generating units at the rate of thousands of tones per day
 - quartz content of silt exceeding 90% causes heavy erosion to the tune of several tones of stainless steel every monsoon
 - the silt problems of Himalayan rivers and Yellow river of China are unique in the world and the turbine manufacturers all over the globe will have to take note of the silt menace and come up with effective design and O & M solutions to save the underwater components

Approach to encounter silting problems

A three dimensional approach is desirable to encounter silting problems in hydro power plants as stated below:

- Catchment area treatment for reduction of silt load
- Effective de-silting arrangements for prevention of silt
- Silt resistant equipment for withstanding the silt.

Silt resistant equipment design

Silt resistant equipment design can be considered under the following three broad heads

- Hydraulic design
- Mechanical design
- Material technology

Hydraulic Design

Hydraulic design criteria for erosive environment

While passing through the generating units, suspended silt in water is subjected to the forces of gravity, viscosity, inertia, turbulence and cavitations. Combination of these forces makes silt movement highly complex under varying velocity profiles and pressure gradients. Hydro abrasion is mainly caused by abrasive particles being transported into the vicinity of wetted surfaces. Some of the particles flowing with the water through hydraulic machines are transported by centrifugal force towards these surfaces, and each time a particle impinges on a surface, the energy released during deceleration removes a small amount of material. A few instances have been noticed where under identical conditions of silt, the intensity of damages at different power stations were not identical. While components at particular power stations eroded very fast, damages to components at other power stations were significant. This leads one to believe that equipment design has a role to play in influencing the intensity of erosion. In the existing

power stations, counter measures are restricted to:

- replacing critical components like runner and guide vanes within the existing turbine space
- coating the surface of underwater parts with abrasion resistant material
- observing minutely the silt load patterns vis-à-vis the damage caused and accordingly evolve the operational criteria of the plant
- stocking spare parts for modular maintenance

Factors responsible for silt erosion

Silt erosion is a result of mechanical wear of components on account of dynamic action of silt flowing in the water coming in contact with wearing surface. Therefore, silt flowing with water passing through the turbine is the root cause of silt erosion of turbine components. Since the silt erosion damage is on account of dynamic action of silt with the component; properties of silt, mechanical properties of component in contact with the flow and conditions of flow are jointly responsible for the intensity and quantum of silt erosion. An interdisciplinary approach is needed to tackle this problem in all its dimensions.

8.1.4 FOREBAY TANK

When the load on the generator decreases the governor reduces the rate of flow of water striking the runner in order to maintain the constant speed of runner. But the sudden reduction of the rate of flow in the penstock may build a water hammer in the pipe, which may cause excessive inertia pressure in the pipe line due to which the pipe may burst. Two devices, viz. the deflector and relief valve are provided to avoid the sudden reduction of the rate of flow in the penstock. But neither of these devices is of any help when the load on the generator increases and the turbine is in need of more water. Thus in order to fulfill both the above objectives in addition to the deflector or relief valve certain other devices such as surge tank and forebay are provided. Surge tanks are employed in case of high head and medium head power plants where the penstock is very long and forebays are suitable for medium head and low head power plants where the length of the penstock is short.

Power House

According to the location of the hydel power station, the power houses are classified as surface power house or underground power house. As the name implies, the underground power house is one which is built underground. A cavity is excavated inside earth surface where the sound rock is available to house the power station. A surface power house is one which is founded on earth's surface and its superstructure rests on the foundation. The surface power house has been broadly divided into three subdivisions which is separated from the intake as mentioned below:

- Substructure
- Intermediate structure
- Super-structure

Substructure

The substructure of a power-house is defined as that part which extends from the top of the draft tube to the soil or rock. Its purpose is to house the passage for the water coming out of the turbine. In case of reaction turbines, the hydraulic function of the sub-structure is to provide a diverging passage (known as draft tube) where the velocity of the exit water is gradually reduced in order to reduce the loss in pushing out the water. In case of impulse turbine, such

a draft tube is not required and only an exit gallery would serve the purpose. The structural function of substructure is dual. The first function is to safely carry the superimposed loads of machines and other structures over the cavities. The second function is to act as transition foundation member, which distributes heavy machine loads on the soil such that the obtainable ground pressures are within safe limits.

Intermediate structure

The intermediate structure of a power house may be defined as that part of the power house which extends from the top of the draft tube to top of the generator foundation. This structure contains two important elements of the power house; one is the scroll case which feeds water to the turbine. The generator foundation rests on the scroll-case which is embedded in the concrete. The other galleries, adits and chambers also rest on the same foundation. Scroll or spiral case is a part of the turbine and it distributes water coming from penstock uniformly and smoothly through guide vanes to the turbine. The scroll case is required only in case of reaction turbine. In case of impulse turbine the place of scroll case is taken by the manifold supplying water to the jets.

The structural function of the concrete around scroll case would depend upon the type of scroll case used. If the scroll case is made of steel and strong enough to withstand internal loads including the water hammer effects, the surrounding concrete acts more or less as a space fill and a medium to distribute the generator loads to the substructure. If it is a concrete scroll case then this concrete should be strong enough to withstand the internal hydrostatic and water hammer head as well as the external superimposed loads on account of the machine etc. Many times, the steel scroll case is used as water linear and in this case the surrounding concrete must be strong enough to withstand the internal hydraulic pressures in addition to the superimposed loads. The structural function of the generator foundation is to support the generator. Arrangements may be made either to transmit the load 'directly to the substructure through steel barrel or through a column beam or slab arrangement.

Superstructure

The part of the power house above the generator floor right upto the roof is known as superstructure. This part provides walls and roofs to power station and also provides an overhead traveling crane for handling heavy machine parts.

The arrangement of the power house is shown in Fig 1.

Arrangement of Reaction and Impulse Turbines

Factors affecting the choice between horizontal and vertical setting of machines are: relative cost of plant, foundations, building space and layout of the plant in general.

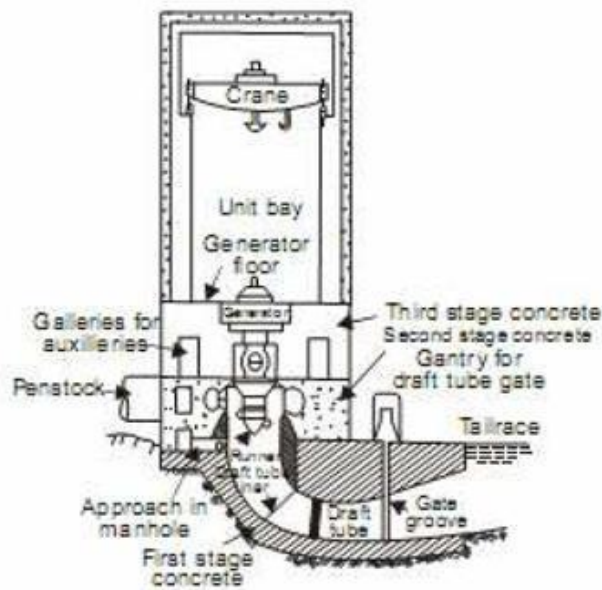

Figure 1 Arrangement of the power house

Vertical machines offer many advantages over horizontal especially when there are great variations in tail-race level. Horizontal machines turbine-house should be above the tail-race level or the lower part of the house must be made watertight. In vertical machines, the weight of rotating parts acts in the same direction as axial hydraulic thrust. This requires a thrust bearing capable of carrying considerable heavy load. The efficiency of the vertical arrangement is 1 to 2% higher than for a similar horizontal arrangement. This is due to the absence of a suction bend near the runner. As the alternator being mounted above the turbine, it is completely free from flooding. With the horizontal machines, there may be two turbines driving one generator and turbines would operate at a higher speed bringing about a smaller and lighter generator. The horizontal machines would occupy a greater length than the vertical but the foundations need not be as deep as required for vertical machines. The horizontal shaft machines require higher settings to reduce or to eliminate the cost of sealing the generator, the auxiliary electrical equipment and cable ducts against water. In actual cases, the arrangement of the machine (vertical or horizontal) is so chosen which will give the lowest cost of the station. The majority of impulse turbines are of the horizontal shaft types. The horizontal arrangement is simpler than vertical from constructional and maintenance point of view. The overall height and width of the station will be relatively greater in case of vertical arrangement. The floor space occupied by horizontal shaft units is in general greater than that required for vertical shaft machines. Horizontal shaft arrangement is adopted in most cases, for Pelton wheels, mainly because this type of setting lends itself readily to the use of multiple runner units and secondly, because the resulting hydraulic conditions are not favorable with vertical machines.

There are mainly two principal types of setting as: (1) open flume and (2) cased turbines. The open flume setting as shown in Figure 2 (Rewalls power plant on black river at Watertown in U.S.A.) is chiefly used for low heads with concentrated falls or with a short canal. Open penstock setting is one where the entry to the runner has no casing but is placed in an open forebay. The runner should be placed at a convenient depth below the water surface such that eddies and suction of air through vertices will not take place. The turbine is completely submerged which results in a simple and comparatively cheap plant. The disadvantage of this arrangement is that the pit must be drained to enable inspection and maintenance to be carried out on the turbine and guide vane mechanism. The turbine should have an adequate water head above it; otherwise a sudden increase in load may draw the water to a dangerous level and allow

air to enter. Such condition would break the vacuum in the draft tube and stop the turbine.

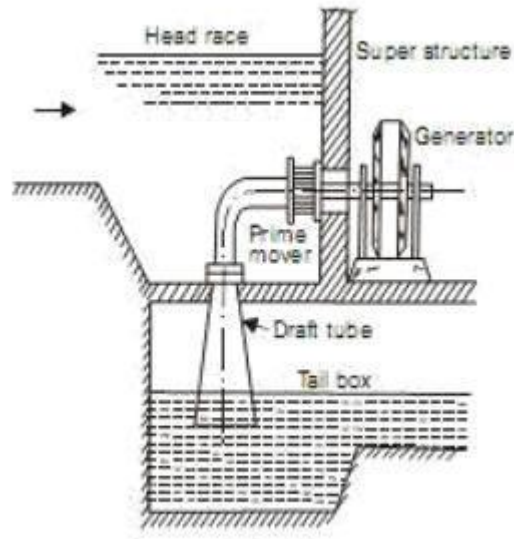

Figure 2 Open flume setting

The cased turbines are further divided as concrete casing or steel plate casing as mentioned earlier. The width of the concrete flume should be kept as small as possible as design permits because the concrete approach flume often fixes the machine spacing. The concrete scrolls are limited to low head installations upto 20 metre heights. The complicated form work and reinforcement required for a concrete flume makes it expensive so that other methods of construction have to be used. Steel plate scrolls are used for heads ranging from 10 m to 120 m. The arrangement of steel scroll is shown in Figure below.

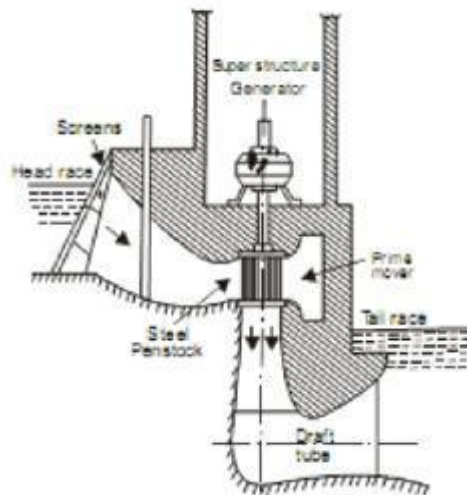

Figure 3 Arrangement of steel scroll

Underground Power House

The conventional hydro-electric power stations are usually located over-ground at the foot of a dam or a hill slope on the banks of a river. The first underground power station Nerayaz was built in 1897 in Switzerland. The high capacity

underground power plants were built only after Second World War. The idea of locating powerhouse underground was suggested not only with the intention of protecting them against air raids but also technical and economical considerations were mainly considered. After Second World War, the immunity against air attacks was unquestionably regarded as an important. A large number of underground power stations have been installed in U.K., U.S.A., Russia, Canada and Japan after Second World War and recently in India also. In all, there are about 300 such stations in service with a total installed capacity of 31 million kW. The considerations supporting the construction of underground power stations are stated below:

- Non-availability of a suitable site for a conventional surface station and good slope for penstock.
- Danger of falling rocks and snow avalanches particularly in narrow valleys.
- Availability of underground sound rock and avoidance of a long pressure tunnel and facility for a convenient tail-race outlet.
- Possibility of elimination of surge tank required for surface station due to long pressure tunnel
- The rugged topographical features and the difficulties in finding a suitable short and steep slope for pipe lines make it more economical to install the water conduit, the machine, and transformer hall and tailrace system underground.
- Foundation costs for over ground power house become excessive in case of poor quality surface layers. The construction of draft tube, spiral case and separating floors in loose weathered rock is again more expensive than the excavation of corresponding parts underground. The costs of underground machine hall are lower than those of the superstructure of a surface powerhouse of similar dimensions.

Advantages and Disadvantages of underground power house

Advantages

- Under suitable geological conditions, the underground conduit may prove the shortest and sometimes even straight. The power conduit may be much shorter than the length of power canal used for underground power house as the power canal usually built to follow the contours of the terrain. By locating the power house underground, the number of restrictions as safe topographical and geological conditions along the penstock and sufficient space at the foot of the hill for constructing the power house are completely eliminated.
- The construction of underground conduit instead of penstock results in considerable saving in steel, the internal pressure is carried partly by the rock if it is of good quality. In sound high quality rock, the penstock is replaced by an inclined or vertical pressure shaft excavated in rock and provided with a steel lining of greatly reduced thickness in comparison with exposed penstock 'roe purpose' of lining in such cases is protection against the seepage losses.
- The reduced length of the pressure conduit reduced the pressures developed due to water hammer. Therefore, smaller surge tank is also sufficient.
- For the economical arrangement, the ratio of the pressure conduit to the tail-race tunnel is also significant. The overall cost of the system is lower if the tail-race tunnel length is relatively large.
- The construction work at underground power station can continue uninterrupted even under severest winter conditions. The overall construction cost and period of construction is reduced due to continuity of work.
- Much care is devoted today in many countries to preserve landscape features such as picturesque rock walls, canyons, valleys and river banks in their original beauty against spoiling by exposed penstocks, canal basins and machine halls. There is less danger of disturbance to amenities with an underground power house and pipelines. The other advantages gained by constructing underground power house are listed below. The six

advantages mentioned above reduce the constructional difficulties and overall cost of the plant and preserve the original beauty of landscape. The overall cost is further reduced by the modern techniques in tunnel work and better excavation process.

- The shorter power conduit of underground power house reduces the head losses.
- The regular maintenance and repair costs are lower for underground stations as the maintenance required for rock tunnels is less.
- The power plant is free from landslides, avalanches, heavy snow and rainfall.
- The useful life of the structures excavated in rock is considerably longer than that of concrete and reinforced concrete structures.
- It is possible to improve the governing of the turbines with the construction of underground power house.
- The construction period is reduced mainly due to the possibility of full-scale construction work in winter.
- Underground power station is bomb-proof and may be preferred for military reasons: They are perfectly protected against air-raids. The military considerations became more predominant with the increased shadow of the war and the building of underground power stations underwent a rapid evolution after Second World War.

Disadvantages

- The construction cost of the underground power house is more compared with the over ground power house:
 - The excavation of the caverns required for housing the turbine generator units and auxiliary equipments (machine hall of Koyna project is $300' \times 120' \times 60'$ in dimensions) is very expensive.
 - The costs of access tunnels are considerable.
 - The separate gallery excavated for the inlet valves adds the extra cost.
 - The construction of air ducts and bus galleries also adds in total construction costs.
 - Special ventilation and air-conditioning equipment required for underground adds in the constructional costs.
 - In some cases, the tailrace tunnel of an underground power house requires a more elaborate solution than a tailrace tunnel designed for the surface arrangement. The advantage gained by reducing the pressure conduit would be lost by extending the tailrace tunnel.
 - The first cost is also increased by locating the transformer and high-voltage switchgear underground. The above-mentioned constructions increase the capital cost of the plant.

(v) The operational cost of the power plant increases due to following reasons:

- The lighting cost.
- The running cost of air-conditioned plant.
- The removal of water seeping may be more costly than for the surface arrangement.

Adequate lighting, proper ventilation, maintenance of uniform climatic conditions within the power houses, provision of the necessary safety equipments against flooding, maintenance of proper acoustical conditions, augmenting the feeling of safety by providing a sufficient number of well placed exit; and finally artistic shaping and outfitting of machine hall increases the overall cost of the underground power house compared with ground surface power house.

The choice of the site for the power house either over ground or underground requires a considerable economical analysis according to the available topography and no thumb rule can be applied for its selection.

Types of underground power stations

There are mainly five different types of underground power stations as per hydraulic characteristics.

- *Free level tailrace tunnel without a downstream surge tank.* In this arrangement, the long and steep tailrace tunnel is built to cope with the discharge without putting the tunnel under pressure, both under steady and unsteady flow conditions. This type is more suitable with Pelton wheel because it does not interfere with the flow in tailrace tunnel. The underground Innertkirchen power house in Switzerland is the example of such Construction. The head is 672.3 meters, length of pressure tunnel is 10 kilometers and tailrace tunnel is 1294 meter with a slope of 4: 1.

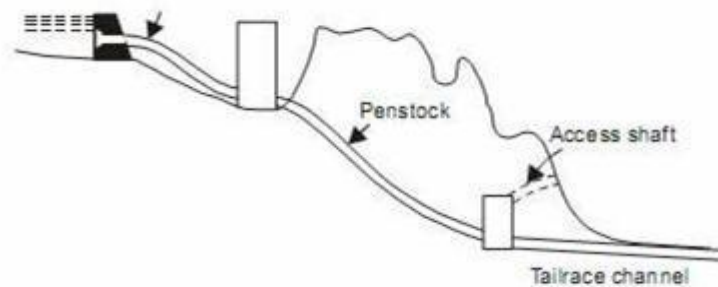

Figure 4 Free level tailrace tunnel without a downstream surge tank

- *Downstream station arrangement or Alpine type.* The arrangement is shown in Fig 5. below. In this arrangement, the water is carried through a long horizontal pressure tunnel to the point of emergence to the surface, from where a steep pressure shaft continues down to the power house as shown in figure. A surge tank is provided at the junction of pressure tunnel and pressure shaft as in the case of exposed penstock and surface power station. The valve chamber after the surge tank is also provided underground and the valves are also provided before the prime-mover. These valves may be located either in the main cavern or a separate valves gallery is excavated for this purpose. Access to both surge tank and power house is provided through horizontal tunnels as shown in Figure. The tailrace tunnel is considerably short in length. The arrangement is generally preferred in mountain regions. The downstream surge tank is also used if a tailrace tunnel is long and considerable surges are likely to occur in the tail water.

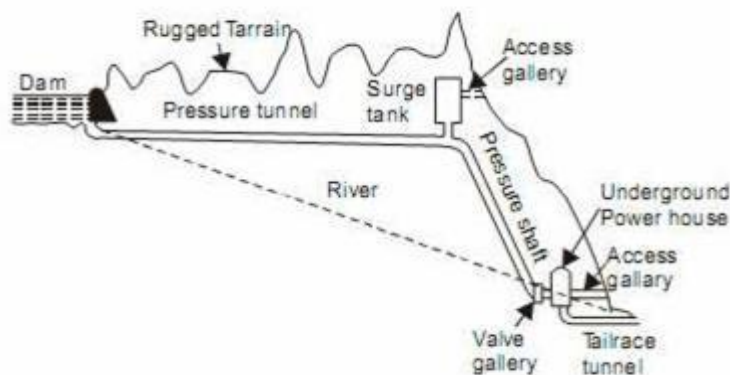

Figure 5 Downstream station arrangement

- *Intermediate station arrangement.* Figure 6 shows the economic site of the power house at an intermediate section of the entire power conduit. The specific characteristic of this arrangement is long headrace tunnel and a long tailrace tunnel. Upstream and downstream surge tanks are necessary as shown in figure to deal with the pressure oscillations in both headrace and tailrace. If the prime mover is impulse type, there is no interference between tailrace and headrace level and, therefore, the dimensions of both surge tanks can be calculated independently according to the usual surge theory. If the prime mover is reaction type, the oscillations in tailrace and headrace interfere with each other and, therefore, the larger areas of surge tank is required than the volume required for surge tank used with impulsive type prime mover.

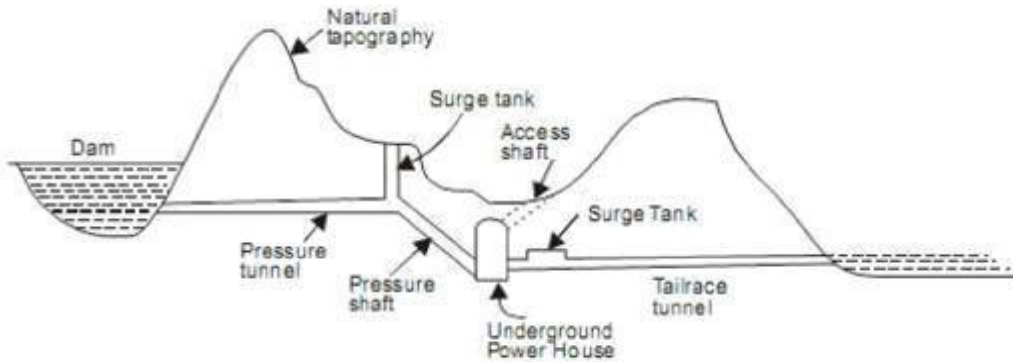

Figure 6 Site of the power house

The Santa Giustina power house in Italy is an example of this type of arrangement. Koyna power project also comes under this class except there is no surge tank to the downstream side as the tailrace tunnel is not very long.

- *Station arrangement without surge tank.* If the pressure tunnel and tailrace tunnel are short in length, the upstream and downstream surge tanks can be eliminated from the system. The main points to be considered in this design are the maximum water hammer effect and danger of cavitations in the turbine. The latter can be eliminated by selecting the proper turbine axis level above the draft tube axis level.

Vertical or steep shafts (10: 1) are provided to access the upstream or Swedish type power house whereas horizontal or mild sloping tunnels prove more favorable for downstream stations or Alpine type layout. Generally fresh air as supplied to the power house through the main access tunnel and warmed up air is exhausted along the same tunnel through a separate duct. Sometimes separate air shafts are used to exhaust the warmed up air.

The transformers and high voltage switching equipment were previously located outdoors almost without exception. In recent practice, transformers are also arranged underground in the transformer room excavated in the vicinity of power house. If the decision of the management is in the favor of underground power house against air-raids, no significant gain could be achieved by locating the transformer outdoor as it is one of the most sensitive and essential components of the power project. An underground location of the transformer is further supported by the fact that the location of the transformer near the power house involves hardly any excess cost.

8.2 ECONOMICS: COST STRUCTURE, INITIAL AND OPERATION COST

The economics of a hydropower plant is quite different from that of any other type of power plant since various considerations such as water supply, irrigation and river navigation are involved besides regular economic aspects of cost of generated power. In fact, some of these aspects, such as effect on irrigation or recreation facilities are difficult to quantify. Hence, true economic analysis of a hydro power plant, especially a large hydro power plant, is a mix of quantitative and qualitative approaches. The major benefits and cost components for estimating annual the net benefits from a hydropower plant are shown in figure and defined below:

- *Gross power benefits:* These benefits reflect the income from sale of power or avoided cost of power if the hydropower plant did not existing and power has taken from costlier source.
- *Benefits of avoided pollution:* Relative to alternative types of power generation, such as a coal-fired plant, hydropower production generates less air pollution or greenhouse gases. The avoided pollution is considered as a benefit of hydropower projects.
- *Costs of operation:* This type of costs reflects investment costs for the project, anticipated future reinvestment costs, and current operation and maintenance (O&M) costs.
- *Benefits of project services:* Beyond power generation, hydroelectric projects may offer benefits such as flood control, water supply, irrigation, river navigability and improvement of infrastructure and economical prosperity of the region.
- *Costs of environmental measures:* Many licensing decisions introduce operating conditions designed to protect, mitigate damages to, or improve environmental quality. These changes may result in direct costs and/or reduced power values from the viewpoint of the hydropower station owner. There are direct costs associated with, for example, construction of fish passage facilities. Similarly, due to environmental measures to protect flora and fauna sometimes flow of water is restricted that may reduce power generation either because they cause direct losses in available flow or they shift power generation from periods when energy prices are high to periods when energy prices are low.
- *Benefits of environmental measures:* Environmental measures, such as fish screens or changes in minimum flow requirements, can improve fish and wildlife resources, recreational opportunities, and other aspects of environmental quality. Since these benefits are different from the direct revenue from sale of power, they are often referred to as “non-power” benefits.

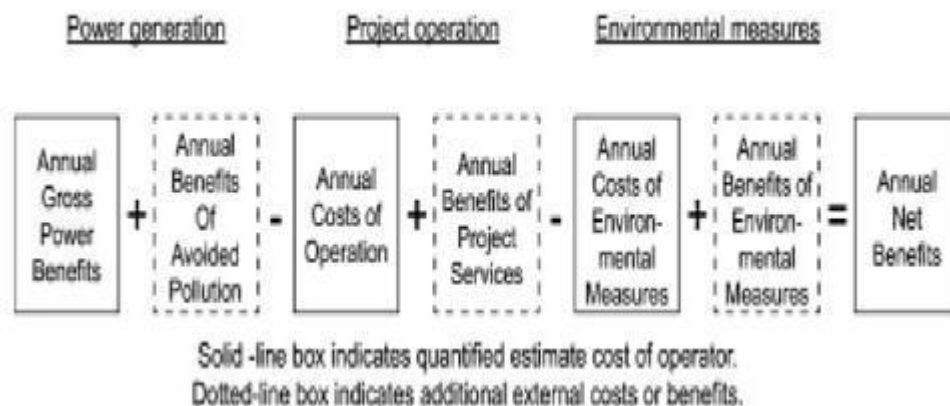

Figure 7 Overview of economic analysis of hydro power plant

Details related to the cost structure are presented in the following sections.

Cost Structure

Initial Cost

The cost of hydropower plants can hardly be generalized since every site may offer a unique set of challenges, such as the lengths of pipes and tunnels, the difficulty in transporting equipment due to a poor road network, or necessary investments in infrastructure, different geology etc. that are reflected by the plant cost and hence on the cost of generated power. The initial costs of hydropower plants are usually found to vary between Rs.66, 640–3, 33,200 per kW depending on the size of country and location.

Operation Cost

The operation and maintenance cost of hydropower plants comprises three major components: Maintenance of plant machinery including replacement of part, salary of staff, and insurance. The life of hydropower plants ranges from 20 years to 40 years and beyond. For financial calculations, usually a calculative lifetime of around 30 years is considered.

Maintenance Costs

The maintenance cost of plant machinery has two major components, preventive maintenance and breakdown maintenance. Per year, approximately 3–5% of the capital investment can be considered as O&M cost of plant equipment in the initial years, which usually increases as the plant gets older.

The turbine runner is the part that requires most of the maintenance work. Due to the cavitation effect or due to the hammering action of the silt arriving with the water, the runner blade gets damaged. This damage is predominant in some countries during the rainy season when the incoming water in the reservoir carries lot of eroded sand, and as the retention time in the reservoir or the stilling basin is reduced, the quality of the water arriving at the turbine is relatively poor. For this reason it is general practice during the season when the power demand decreases, to remove the runners of a multi-turbine power plant for repair turn by turn.

In addition to maintenance, another important cost element is insurance costs. Insurance of hydro turbines and dams is required to secure the loss of their high investment fully or partially in cases where parts are damaged and also to cover the huge possible loss due to flooding if something goes wrong with the dam.

Plant Utilization Factor

In theoretical calculations, hydro power plants are assumed to be available for power generation whenever water is available. In practice, however, this may not be true in all situations. With modern preventive and predictive maintenance practices of advanced plant control, the availability of hydropower plants has increased over the past decades. The best plants may be available for about 95% of the time. The unavailability of water for full capacity utilization of a hydropower plant though becomes a constraint. Due to this factor, the plant utilization ranges from 60–80%. In some very good locations, where water availability is consistent due to a mix of rain-fed and snow melting systems, and where the reservoir has a large capacity of storage, an even higher plant utilization factor (PLF) can be achieved. On the other hand, in case of very small plants, this factor may even be lower than 50%.

Salary and Administrative Expenses

Since a hydropower plant requires continuous monitoring and maintenance, the salary component cannot be ignored in

the financial analysis. Old power plants used to require more persons to operate and control various systems, whereas, due to automatic controls, new plants require much less manpower.

8.2.1 ENVIRONMENTAL ISSUES RELATED TO SMALL AND LARGE HYDROPOWER PLANTS

Hydropower is a renewable and economic energy source, less subject to price fluctuations than energy sources using fossil fuels. Hydro stations can be started and stopped quickly and are able to accommodate system load variations, making them ideally suited for meeting system peak loads.

There are however a number of concerns in the development of hydropower, and the development effectiveness of large dams has been a topic of international discussion in recent decades. Dams impact river ecosystems and the livelihoods and cultural heritage of the populations of river basins. River ecosystems are considerably affected in a number of ways. Dams block rivers and reduce downstream river levels, thus reducing the amount of water in the downstream ecosystem and impeding the passage of nutrients and silt, and fish and other aquatic organisms. Fish habitat is further affected by alterations to the water temperature, oxygen and silt levels, and speed of river flows. As a result fish migration and fish spawning in upstream watercourses are considerably impacted. These impacts can be mitigated to a certain extent by targeted strategies such as fish passages for both upstream and downstream movement, and by maintaining environmental flows downstream of the dam site. Water quality can be controlled by using multilevel off takes and aerating turbines, by removal of vegetation from the impoundment, and by integrated watershed and erosion management practices in the water catchment area. In some regions, the introduction or excessive proliferation of natural or exotic pest species has resulted in additional adverse biological impacts such as algae blooms. Another negative impact can be increased risk to human health because of higher mosquito populations or an increased uptake of contaminants in the food chain. Therefore, any potential development of hydropower should address these considerations in a strategic environmental assessment that deeply integrates environmental and social considerations in the decision making process, based on, among other things, a comprehensive review of alternatives to hydropower development. During construction and operation of a hydropower plant, all activities and impacts should be monitored and executed according to an environmental management system agreed upon by the various stakeholders in the region.

World Commission on Dams (WCD) estimated that between 40 and 80 million people had been displaced from their lands by large dams, at times resulting in economic hardship, disintegration of communities, and loss of the natural resources upon which community livelihoods depended. As a result, the benefits of hydropower development have gone disproportionately to the affluent and rich segments of the population, while the poor have borne many of the costs. This is one of the feared outcomes of hydro development in the Northeastern Region of India, where hydropower development would mainly take place in the tribal areas in the hills.

The seismicity of the Northeastern Region is a critical issue that needs to be adequately addressed in any water resource development project. The region lies at the junction of the Himalayan arc to the north and the Burmese arc to the east and is one of the six most seismically active regions of the world. In the last 100 years as many as 18 large earthquakes have been recorded from this seismotectonic domain, two of which – in 1897 and 1950 – were among the most powerful recorded globally.

8.3 POTENTIAL OF HYDRO POWER IN NORTH EAST INDIA

Northeast is well known for immense hydro potential. The first comprehensive study carried out during 1953–1959 by the then Central Water and Power Commission’s Power Wing (reconstituted as the Central Electricity Authority) estimated the economically exploitable hydro potential of the Brahmaputra basin at 13,400 megawatts at 60 percent load factor, which constituted about 32 percent of the country’s hydropower potential of 42,100 megawatts at 60 percent load factor.

Reassessment studies were carried out by the Central Electricity Authority during 1978– 1987 taking into account further detailed topographic and hydrological data, advances in design and construction technology, and emerging trends in energy costs. This study placed the hydropower potential of the country at 84,040 megawatts at 60 percent load factor from a total of 845 projects, which would yield energy of 442 billion kilowatt-hours per year. With seasonal energy, the total energy potential is assessed to be 600 billion kilowatt-hours per year. The hydropower potential of the major river basins of the country, according to the two studies, is shown in table 1.

Table 1: Assessments of hydropower potential of major basins

Basin	Potential (MW) at 60% load factor		No. of identified schemes: Reassessment study (1978-87)
	First survey (1953-59)	Reassessment study (1978-87)	
Indus	6583	19988	180
Ganga	4817	10715	226
Central Indian	4300	2740	142
West-flowing	4350	6149	63
East-flowing	8633	9532	84
Brahmaputra	13417	34920	140
Total	42100	84044	845

About 75 percent of the potential of the country comes from the Himalayan river systems (the Indus, Ganga, and Brahmaputra) and is located in the Northeastern (39.4 percent) and Northern (35.9 percent) power regions. The hydropower potential of the Northeastern power region, including Sikkim, is around 36,000 megawatts at 60 percent load factor, almost all of which excluding Sikkim is from the Brahmaputra basin.

The potential developed so far in the Northeastern power region (including the state of Sikkim) is only 1.72 percent, which is much less than the 18.91 percent developed in the country as a whole. Even after completion of the hydro schemes under construction, the potential exploited in the region would be 4.84 percent, compared to 24.13 percent with completion at the national level. The potential development including the schemes cleared by the Central Electricity Authority would be 6.05 percent in the Northeastern power region and 27.74 percent in the country as a whole. The regional level of hydro potential development (including schemes cleared by the Central Electricity Authority) is expected to be 31 percent in Northern, 63.71 percent in Western, 61.26 percent in Southern, and 40.5 percent in Eastern power regions.

Though the unexploited hydro potential (69 percent) in the Northern power region is substantial, the emerging power supply situation indicates that it may be adequate only for meeting the growing power demands within the region. The tentative 11th Power Plan (2007– 2012) proposes addition of 13,886 megawatts of hydro capacity in the region, which is more than 50 percent of the total hydro addition in the country during the plan period. Even with this large hydro capacity addition, the Northern power region would be a net importer of power at the end of the 11th Power Plan

period. Considering this growing power demand in the Northern region there may be little if any surplus for export to other regions.

The total hydropower potential available in Western, Southern, and part of Eastern (excluding Sikkim) power regions is relatively limited, constituting about 25 percent of the potential in the country. The potential exploited in these regions is also relatively high, at 64, 62, and 41 percent respectively. Further, the hydro potential of these regions is from peninsular rivers, which have more than 80 percent of their flows during the monsoon, requiring construction of storage reservoirs for economic hydropower generation. The development of the potential of these river systems is constrained by submergence, environmental, and interstate issues (as with projects in Karnataka and Tamil Nadu, Indravati basin, Western Ghats). There is also concern about the impact of an adverse hydro-thermal mix on the power system in the country, particularly in the Western and Eastern power regions, and also to some extent in the Southern region, where hydro development has slowed down. It is a recognized fact that the operational flexibility and economics of generation of hydro stations make them best suited to peaking power. The hydro development scenario in the Western, Southern, and Eastern power region systems indicates that the future peaking needs of these regions would have to be substantially met from sources outside the region. Lack of complementary peaking capacity in these systems could lead to suboptimal utilization of large base load thermal capacities in these regions. In this context, development of the large unexploited hydro potential in the Northeastern power region assumes importance and urgency.

During 2001, to give further impetus to the efforts for the development of hydropower potential, the Central Electricity Authority undertook a preliminary ranking study of the yet to be developed sites. The study analyzed 399 out of the 845 identified sites (excluding schemes under operation or construction or cleared and small hydro schemes less than 25 megawatts) to determine the priority for development of schemes identified in the reassessment studies. This was followed by the 50,000 megawatt hydroelectric initiative, launched by the Prime Minister of India in May 2003 as part of the Mission 2012: Power for All plans. Under this initiative, preliminary feasibility reports for 162 hydroelectric schemes (spread across 16 states) selected on the basis of a preliminary ranking study, were prepared. The preliminary feasibility reports covered conceptual layouts and planning of the project works, hydrological studies, power potential assessment, determination of installed capacity, cost estimates, environmental aspects (including rehabilitation and resettlement aspects), power evacuation system, and tariff computation. The regional distribution of the schemes is summarized in table 2.

Table 2: Preliminary feasibility reports: Regional distribution of hydro schemes

Region	Number of Schemes	Installed capacity (MW)
Northern	61	11285
Western	17	1464
Southern	8	2107
Eastern	4	1189
North Eastern	72	31925
All India	162	47970

The 31,925-megawatt capacity of the Northeastern power region schemes constituted about 67 percent of the total capacity emerging from the study. The distribution of the schemes by state is shown in table 3.

Table 3: Preliminary feasibility reports: distribution of hydro schemes by NE state

State	Number of schemes	Installed capacity (MW)
Arunachal Pradesh	42	27293
Meghalaya	11	931
Mizoram	3	1500
Nagaland	3	370
Sikkim	10	1469

The Northeastern power region has 30 schemes with an installed capacity of 23,286 megawatts in this economic category. About 50 percent of these schemes (16 schemes, 18,366 megawatts) have first-year tariffs less than Rs. 2.00 per kilowatt-hour. The studies also showed that the potential hydro sites in Western, Southern, and Eastern power regions generally have tariffs greater than Rs. 3.50 per kilowatt-hour, and it would be economical to import power from the Northeastern power region, given a margin of R. 1 or more between tariffs. The substantial block of economic hydro potential available in the Northeastern power region would thus merit serious action-oriented consideration to help meet the future power needs of the country in the first quarter of this millennium. Overall, the Northeastern power region has a vital role to play in the future hydropower development of the country.

Suggested Reading References

7. B.G. Verghese, Water resources in the. Northeast: Development options in a cooperative framework. Background Paper No. 1, September 2006.
8. P K Nag, Power Plant Engineering, 3rd Edition, Tata McGraw Hill, 2008
9. Wagner H. Mathur J. Introduction to Hydro Energy systems: Basic, Technology and Operations, Springer,2011